

CUSTOMER DRAWING

GENERAL TOLERANCE

DIM.RANGE	0.5 - 3	>3-6	>6-30	>30-120	>120-400
TOLERANCE	±0.1	±0.1	±0.2	±0.3	±0.5

REVISION		
REV.	DESCRIPTION	DATE
PA1	NEW RELEASE	2017-3-9
PA2	UPDATED DRAWING	2017/4/5

P/N	R±0.3	S±0.3	F +0.5/-0	T±0.2
10-101949-06	11.91	17.48	9.53	0.61
10-101949-08	15.08	20.62	12.7	0.61
10-101949-10	18.26	23.82	15.88	0.61
10-101949-12	20.65	26.19	19.05	1.40
10-101949-14	23.01	28.58	22.23	0.61
10-101949-16	24.61	30.96	25.40	0.61
10-101949-18	27.00	33.32	28.58	0.61
10-101949-20	29.36	36.53	31.75	0.61
10-101949-22	31.75	39.70	34.93	0.61
10-101949-24	34.93	42.88	38.10	0.61

勝特力電材超市-龍山店 886-3-5773766
 勝特力電材超市-光復店 886-3-5729570
 勝特力电子(上海) 86-21-34970699
 勝特力电子(深圳) 86-755-83298787
<http://www.100y.com.tw>

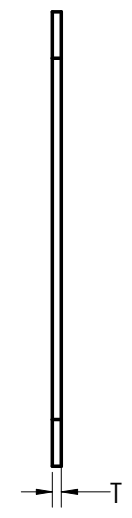
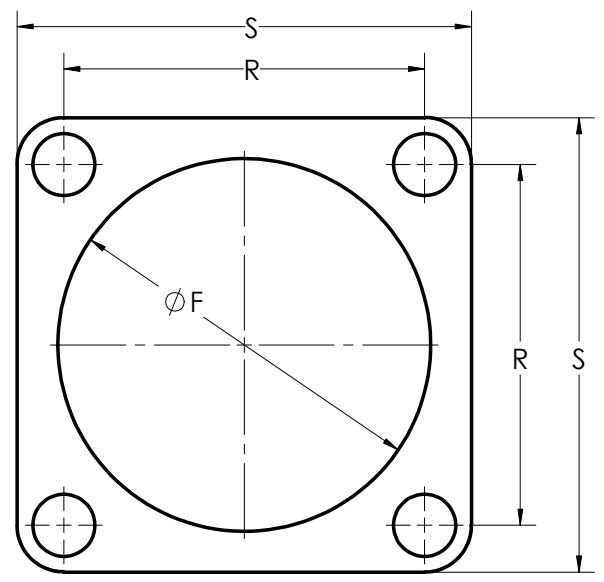

1. THE REFERENCED PRODUCT IS IN COMPLIANCE WITH THE MAXIMUM CONCENTRAT VALUES (MCVS), AS SET BY RoHS 2.0 DIRECTIVE 2011/65/EU AND ANNEX II AMENDMENT DIRECTIVE (EU)2015/863

NOTES:

THIS DOCUMENT CONTAINS PROPRIETARY INFORMATION AND SUCH INFORMATION MAY NOT BE DISCLOSED TO OTHERS FOR ANY PURPOSE OR USED FOR MANUFACTURING PURPOSES WITHOUT WRITTEN PERMISSION FROM THE AMPHENOL CORP.

UNLESS OTHERWISE SPECIFIED	APPROVALS	DATE
LINEAR DIMENSIONS ARE IN: MILLIMETERS TOLERANCES: ANGLES= ±2° DEFAULT LINEAR TOLERANCES SEE TABLE DIM. & TOL. PER ASME Y14.5M-1994; DRM PER MIL-DTL-31000; OTHER AMPHENOL STANDARDS: 9-3800 LEGENDS: =FLAG NOTE CALL OUT REFERENCE THIRD ANGLE PROJECTION	PREPARED BY: Peter.ling	Apr-05-17
	ENGINEER IN CHANGE: Peter.ling	
	DESIGN MANAGER: Ran.Xiao	
	PRODUCT GROUP: C&3	
	AIPG DIVISION:	
	MATERIAL SPEC	PROCESS SPEC

AMPHENOL INDUSTRIAL OPERATIONS			
Amphenol Technology(Zhuhai)Co.,Ltd No.63, Xinghan Road, Sanzao Town, Jinwan, Zhuhai, PRC			
GASKET,FLAT ELECTRICAL CONNECTOR			
SIZE	CAGE CODE	DOCUMENT NUMBER	REV
C	77820	10-101949-()	PA2
SCALE:	REF:	SHEET 1 OF 1	

10-101949-() SHEET 1 OF 1 REV. PA2

C

B

A

D

C

REV. PA2

SHEET 1 OF 1

10-101949-()

U A

3

2

1

Mouser Electronics

Authorized Distributor

Click to View Pricing, Inventory, Delivery & Lifecycle Information:

[Amphenol:](#)

[C10-101949-010](#) [C10-101949-022](#) [C10-101949-012](#) [C10-101949-016](#) [C10-101949-020](#) [C10-101949-014](#) [C10-101949-018](#) [C10-101949-008](#)