



MS27470 Jam Nut Mount Hermetic Receptacle MIL-DTL-38999 Series I

How To Order: MS

B

Shell Style MS27470 - Jam Nut Mount, Series I	Connector Material / Finish D - Carbon Steel - Fused Tin Finish E - Stainless Steel - Passivate Finish N - Stainless Steel - Nickel Finish	Contact Termination P - Pin, Solder Cup S - Socket, Solder Cup X - Pin, Eyelet Z - Socket, Eyelet C - Pin, PCB D - Socket, PCB Flex Feedthrough Flex Feedthrough				
MS27470	Y	11	N	35	P	A
Class Y- Hermetic	Shell Size 9, 11, 13, 15, 17, 19, 21, 23, 25	Insert Arrangement MIL-DTL-38999 Series I Hermetic Inserts Per MIL-STD-1560; See Pages B-2 - B-4		Alternate Key Position A, B, C, D (Omit for Normal)		

勝特力電材超市-龍山店 886-3-5773766
 勝特力電材超市-光復店 886-3-5729570
 勝特力電子(上海) 86-21-34970699
 勝特力電子(深圳) 86-755-83298787
<http://www.100y.com.tw>

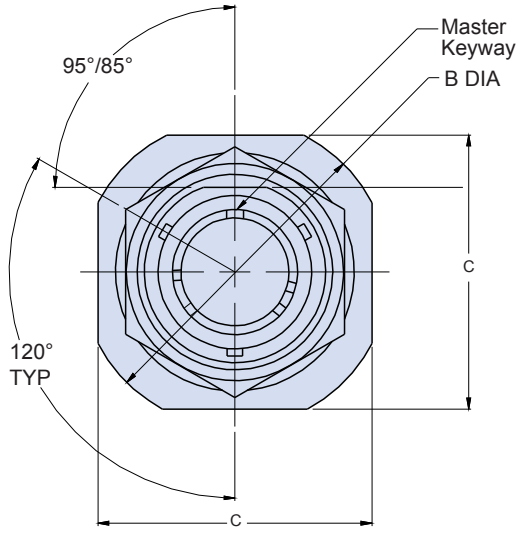
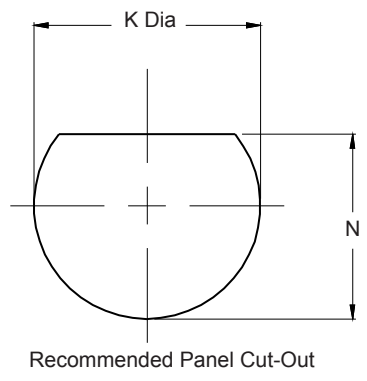
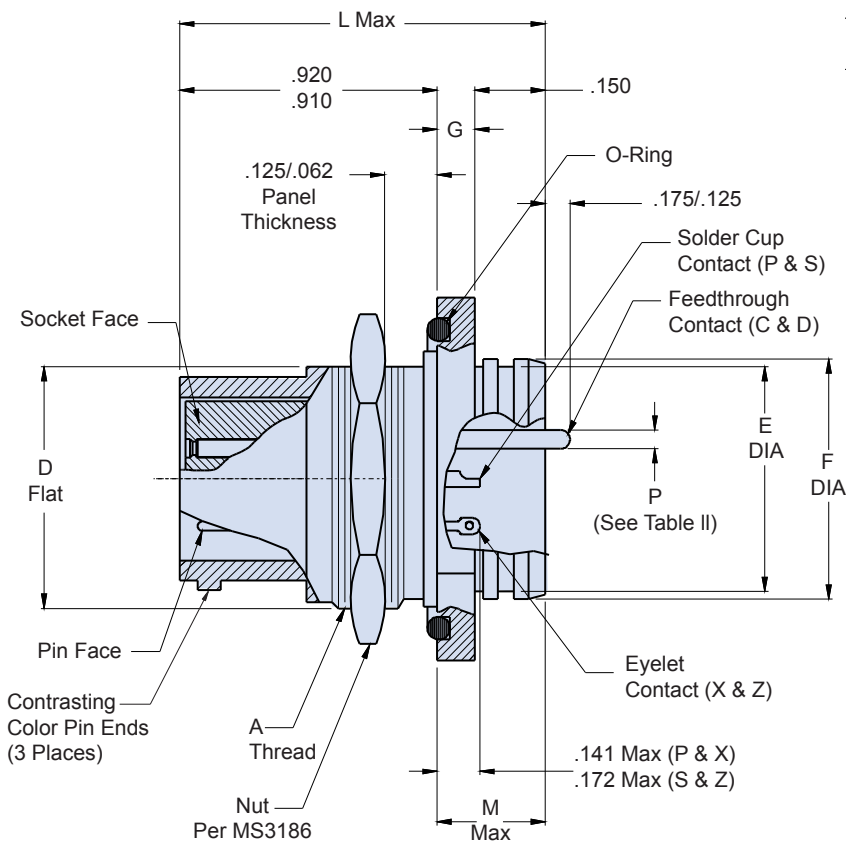

Dimensions in Inches (millimeters) are subject to change without notice.

© 2013 Glenair, Inc. U.S. CAGE Code 06324 Printed in U.S.A.

GLENAIR, INC. • 1211 AIR WAY • GLENDALE, CA 91201-2497 • 818-247-6000 • FAX 818-500-9912
www.glenair.com **B-18** **E-Mail: sales@glenair.com**

