

REV C 1062-12-01 **

REVISIONS			
SYM	DESCRIPTION	DATE	APPROVED
NC	NEW RELEASE PER E.O. P15224	02-17-97	R.D.R.
A	REVISED PER E.O. P15646	05-29-98	R.D.R.
B	REVISED PER E.O. P16979	12-08-00	R.D.R.
C	REVISED PER E.O. P19555	7-11-07	ADR

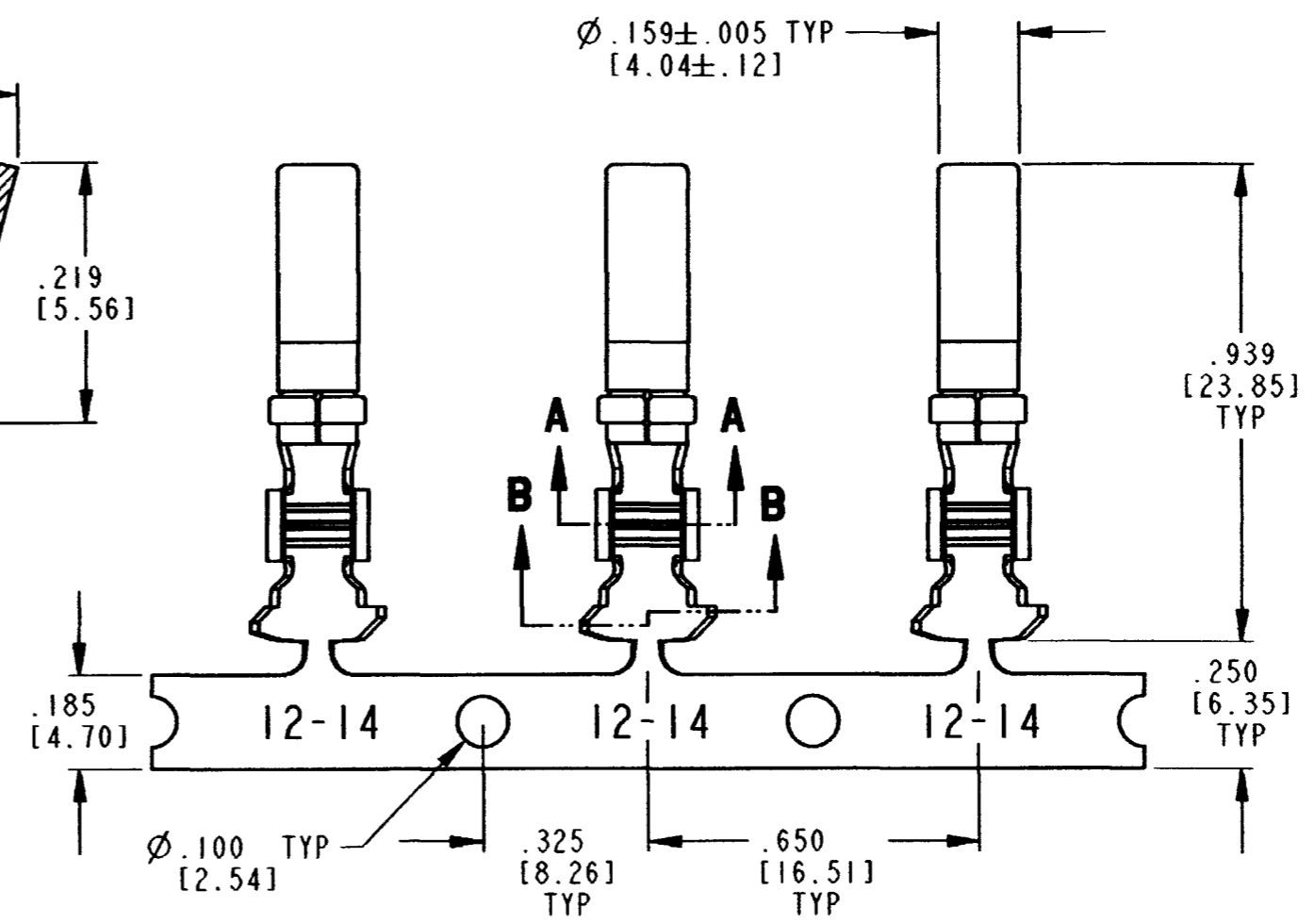
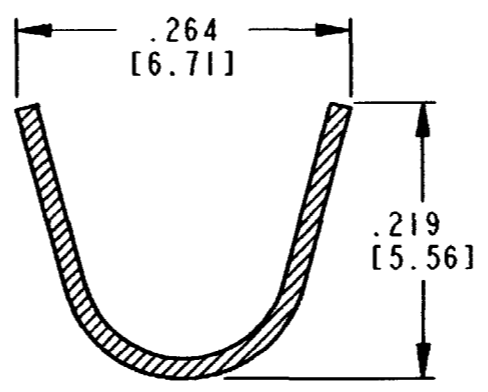
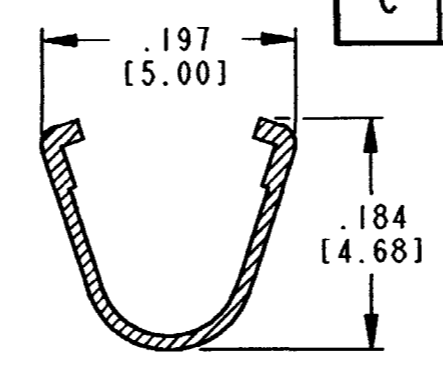

7. CONTACT MATERIAL CONTAINS 94% COPPER MINIMUM. CONTACT SLEEVE IS STAINLESS STEEL.
6. WHEN ** = 44 PLATING IS GOLD.
** = 66 PLATING IS TIN/NICKEL.
5. SEE 0425-015-0000 FOR CONTACT PERFORMANCE AND WIRE APPLICATION CHARACTERISTICS.
4. THIS CONTACT MAY BE CRIMPED WITH DCT12-02-00 AUTOMATIC DIE OR DTT-12-00 HAND TOOL. SEE DRAWING 0425-208-0000 FOR APPLICABLE WIRE SIZE, INSULATION DIAMETER RANGE, AND CRIMPING INFORMATION.
3. ONE REEL CONTAINS APPROXIMATELY 2500 CONTACTS.
2. DIMENSION TOLERANCE: ±.025 [.64].
1. DIMENSIONS ARE IN INCHES [mm].

NOTES: UNLESS OTHERWISE SPECIFIED

勝特力電材超市-龍山店 886-3-5773766
勝特力電材超市-光復店 886-3-5729570
勝特力電子(上海) 86-21-34970699
勝特力電子(深圳) 86-755-83298787
<http://www.100y.com.tw>

SIGNATURE & DATE	
DR	D. MEYER 11/14/00
CHK	[Signature] 7/11/07
PE	[Signature] 7/10/07
APPD	R. Rad 7-11-07
SCALE	NONE WT

STAMPED CONTACT
SOCKET
SIZE 12

ENVELOPE

EP	EP058	MATL. CODE
The Deutch Company DEUTSCH I.P.D. 3850 INDUSTRIAL AVE. HEMET, CALIF. 92545		
B	1062-12-01 **	
DWG SIZE	CODE 11139	SHEET 1 OF 1