

勝特力材料 886-3-5773766  
 勝特力电子(上海) 86-21-34970699  
 勝特力电子(深圳) 86-755-83298787  
[Http://www.100y.com.tw](http://www.100y.com.tw)

# 1. MECHANIC DIMENSIONS

## 1.1. Dimensions

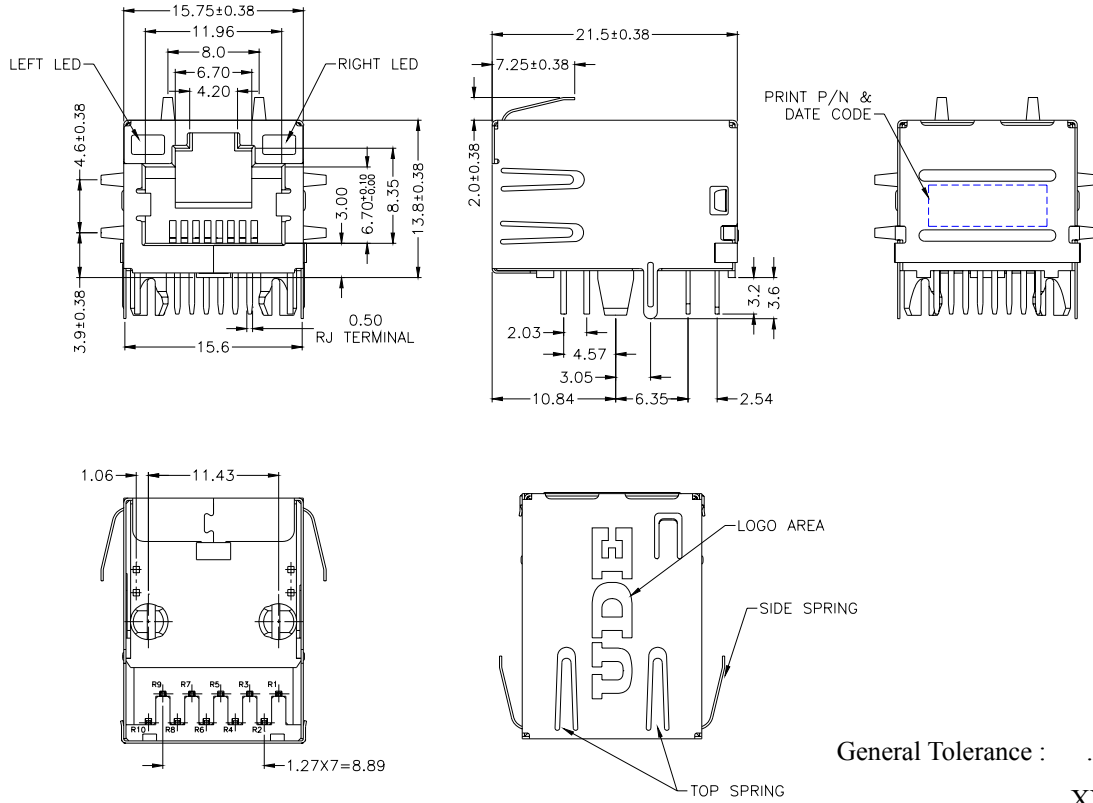

General Tolerance : .X : ±0.25  
 .XX : ±0.13

## 1.2. PCB Layout

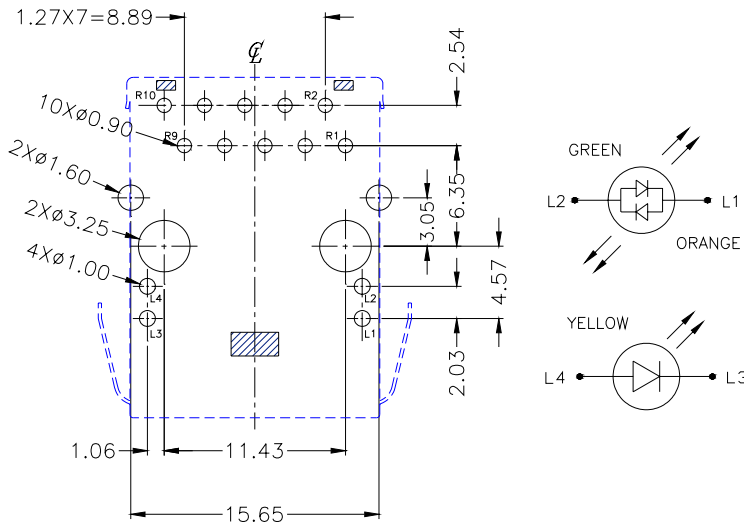

RECOMMENDED PCB LAYOUT  
 COMPONENT SIDE  
 ALL DIMENSION TOLERANCE ARE ±0.05mm  
 UNLESS OTHERWISE SPECIFIED

SPEC NO. :		REV. : XB	ECN NO. :		PAGE :	1 / 6
------------	--	-----------	-----------	--	--------	-------

### 1.3. RJ PLUG SPECIFICATION

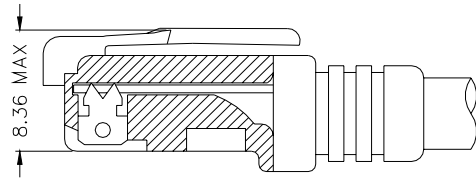
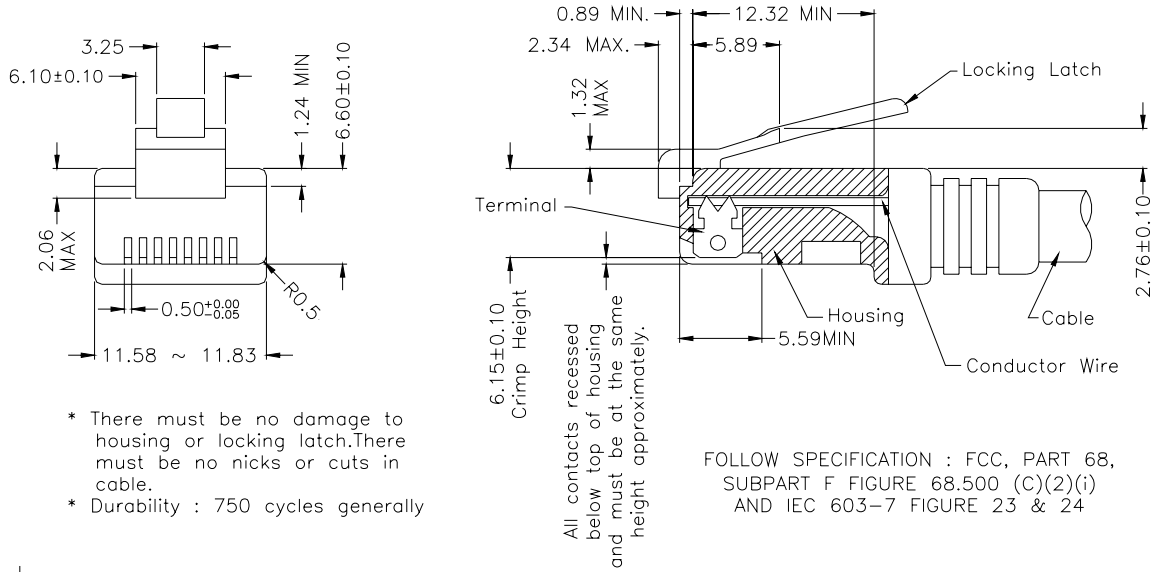

FOLLOW SPECIFICATION : FCC, PART 68, SUBPART F FIGURE 68.500 (C)(2)(ii)

STANDARD MODULAR PLUG ASSEMBLY

## 2. REQUIREMENTS

### 2.1 Design and Construction

Product shall be of design, construction and physical dimensions specified on applicable

### 2.2 Materials

#### 2.2.1 Terminal Parts :

2.2.1.1 RJ Terminal : Phosphor Bronze , Thickness=0.30mm

Finish : ( a ) Contact Area : Gold flash

( b ) Solder tail Area : 100μ” min. Tin

( c ) Underplating : 50~100μ” Nickel over all

2.2.1.2 Input Terminal : Brass , Thickness=0.35mm

Finish : 100μ” min. Tin over 50~100μ” min. Nickel

2.2.1.3 Module Terminal : Brass , Thickness=0.30mm

Finish : 100μ” min. Tin over 50~100μ” min. Nickel

#### 2.2.2 Plastic Parts :

2.2.2.1 Housing : Thermoplastic , PA46 , Black

UL FILE No. : E47960

Manufacturer : DSM Engineering Plastics

Grade : TE250F6

Flame Class : UL94 V-0

SPEC NO. :		REV. : XB	ECN NO. :		PAGE :	2 / 6
------------	--	-----------	-----------	--	--------	-------

2.2.2.2 Coil Case : Thermoplastic , PA46 , Nature

UL FILE No. : E47960

Manufacturer : DSM Engineering Plastics

Grade : TE250F6

Flame Class : UL94 V-0

2.2.2.3 Cover : Thermoplastic , PBT , Nature

UL FILE No. : E59481

Manufacturer : Chang Chun Plastics Co Ltd

Grade : PBT-4830

Flame Class : UL94 V-0

2.2.3 Shell Parts :

2.2.3.1 Shell : Stainless, Thickness=0.20mm

Grounding Leg : Pre-soldering

2.3 Operating and Storage Temperature

2.3.1 Operating Temperature : 0 TO +70

2.3.2 Storage Temperature : -40 TO +85

2.4 Ratings

2.4.1 Voltage rating : 125 VAC

2.4.2 Current rating : 1.5 A

2.5 RJ45 specifications:

2.5.1 Insulation Resistance: 500MΩMin

2.5.2 Dielectric Withstanding Voltage: 1000VAC Min

2.6 Performance and Test Description

Product is designed to meet electrical, mechanical and environmental performance requirements specified in below table. All tests are performed at ambient environmental conditions per MIL-STD-1344A and EIA-364 unless otherwise specified.

2.7 Packaging and Packing

All parts shall be packaged and packed to protect against physical damage, corrosion and deterioration during shipment and storage.

### 3. ELECTRICAL CHARACTERISTICS

#### 3.1 SCHEMATIC

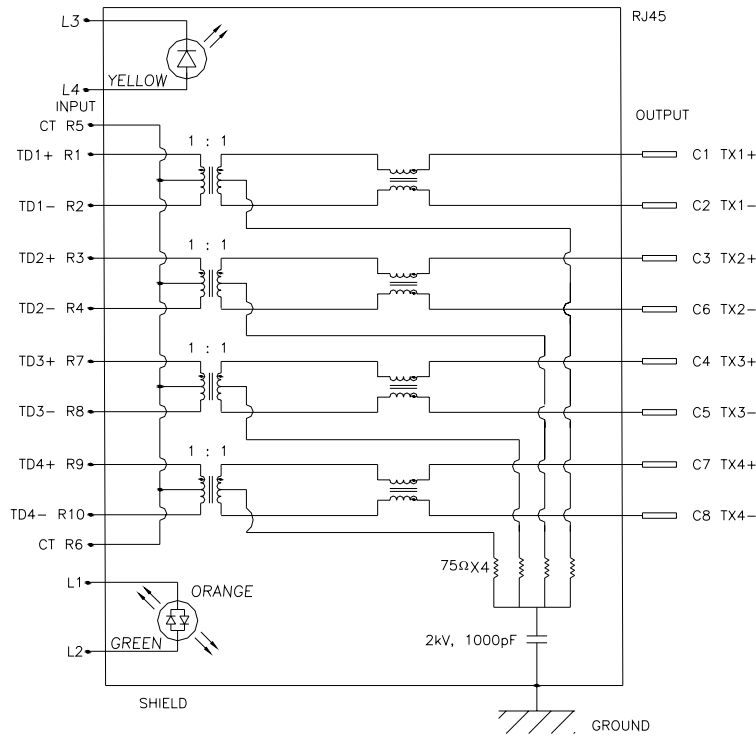

#### 3.2 Transmitter filter & Receiver filter

Type : Balance low pass 100Ω impedance

Insertion loss : 1~100 MHz -1.0dB MAX.

Return loss : 1~30 MHz -18dB MIN. load 100Ω

30~60 MHz -16dB MIN. load 100Ω

60~80 MHz -12dB MIN. load 100Ω

80~100 MHz -10dB MIN. load 100Ω

#### 3.3 Common Mode Rejection

@ 1~100 MHz -30dB MIN.

#### 3.4 Cross Talk

@ 1~100 MHz -30dB MIN

#### 3.5 INDUCTANCE @ 100KHz, 0.1V, 8mA DC BIAS

Input(R1-R2), Input(R3-R4), Input(R7-R8), Input(R9-R10) : 350μH MIN.

#### 3.6 HiPot TEST

Input(R1-R2) to Output(C1-C2) : 1500VAC, 60sec

Input(R3-R4) to Output(C3-C6) : 1500VAC, 60sec

Input(R7-R8) to Output(C4-C5) : 1500VAC, 60sec

Input(R9-R10) to Output(C7-C8) : 1500VAC, 60sec

4 ORDER INFORMATION

R T 7 - 1 X X X XXX X  
A B C D E

A: LED Code

	Left LED		Right LED	
	-L3/+L4	+L3/-L4	-L1/+L2	+L1/-L2
0	w/o	w/o	w/o	w/o
1	Green		Yellow	
2		Green		Yellow
3	Green		Green	Yellow
4	Yellow		Green	
5		Green	Yellow	Green
6	Green	Orange	Yellow	
7	Yellow		Green	Orange
8	Yellow		Orange	Green
9	Green	Orange	Green	
S	Green	Yellow	Green	Yellow
B		Yellow		Green

B: Spring, Logo & Back Leg Code

LOGO \ SPRING	W/O ALL	W/ ALL	W/ TOP ONLY
W/O	0	1	2
W/	3	4	5

C: Board Lock , Post , Shell Leg Code

BOARD LOCK OR POST	NON GREEN PRODUCT		GREEN PRODUCT	
	BOARD LOCK	POST	BOARD LOCK	POST
Rear side leg	1	3	A	C
Front side leg	2	4	B	D

D: Schematic type

AM1 : AM1 Circuit

E: Terminal Contact Area Plating Code

50~100u" Nickel Plating overall

Solder Tail : 100u" min. Tin

A : Gold Flash

D : 15u" Au

F : 30u" Au  
G : 50u" Au

Dipping temperature profile

(Note)The measuring point for the specified temperature shall be on the soldered part of the leads

