

勝特力材料 886-3-5753170
 勝特力电子(上海) 86-21-34970699
 勝特力电子(深圳) 86-755-83298787
 Http://www.100y.com.tw

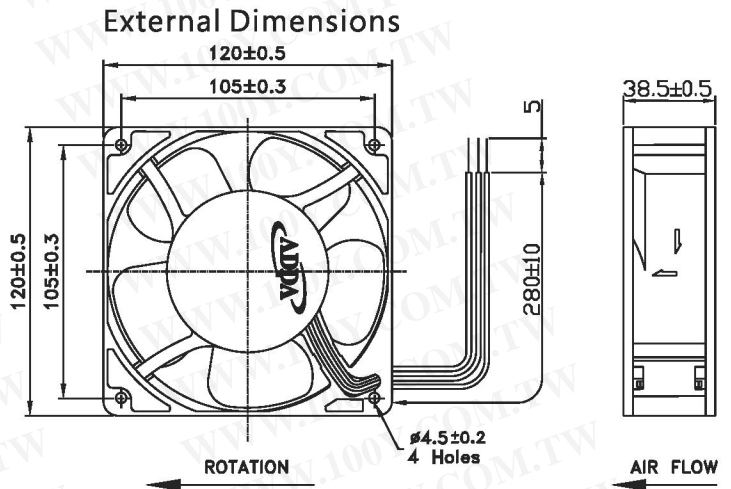

AD12038 SERIES



Frame: Plastic(UL:94V-0), Aluminum
 Impeller: Plastic(UL:94V-0)
 Lead wire: UL1007AWG24

Ps. Two different frame materials (Plastic and Aluminum) can be used for AD12038, please note which kind of material you're interested and inform your sales if needed.

Specifications(Nominal)

*Noise is measured at the distance of one (1) meter from the axis of intake.

Bearing type: ⊙=Ball ※=Sleeve ○=1B1S ●=Hypro bearing

Frame size (mm)	Model No.	Bearing System Type	Rated Voltage (VDC)	Current (A)	Power (W)	Rated Speed (rpm)	Maximum AirFlow (CMM)	Maximum AirFlow (CFM)	Maximum Pressure (InAq)	Maximum Pressure (mmAq)	*Noise Level (dB/A)	Weight (g)
120x120x38	AD1212DB-F51	⊙ ※ ●	12	0.12	1.44	1500	1.621	57.292	0.085	2.159	28.4	235.0 /Plastic 297.0 /Aluminum
	AD1212LB-F51	⊙ ※ ●	12	0.22	2.64	1950	2.027	71.635	0.128	3.251	36.2	
	AD1212MB-F51	⊙ ※ ●	12	0.34	4.08	2540	2.725	96.300	0.228	5.791	45.0	
	AD1212HB-F51	⊙ ※ ●	12	0.39	4.68	2800	2.984	105.461	0.265	6.731	46.7	
	AD1212UB-F51	⊙ ※ ●	12	0.62	7.44	3200	3.399	120.109	0.335	8.509	48.0	
	AD1224DB-F51	⊙ ※ ●	24	0.07	1.68	1500	1.621	57.292	0.085	2.159	28.4	
	AD1224LB-F51	⊙ ※ ●	24	0.10	2.40	1950	2.027	71.635	0.128	3.251	36.2	
	AD1224MB-F51	⊙ ※ ●	24	0.20	4.80	2540	2.725	96.300	0.228	5.791	45.0	
	AD1224HB-F51	⊙ ※ ●	24	0.26	6.24	2800	2.984	105.461	0.265	6.731	46.7	
	AD1224UB-F51	⊙ ※ ●	24	0.38	9.12	3200	3.399	120.109	0.335	8.509	48.0	
	AD1248LB-F51	⊙ ※ ●	48	0.09	4.32	1950	2.027	71.635	0.128	3.251	36.2	
	AD1248MB-F51	⊙ ※ ●	48	0.13	6.24	2540	2.725	96.300	0.228	5.791	45.0	
	AD1248HB-F51	⊙ ※ ●	48	0.18	8.64	2800	2.984	105.461	0.265	6.731	46.7	
	AD1248UB-F51	⊙ ※ ●	48	0.22	10.56	3200	3.399	120.109	0.335	8.509	48.0	

Specifications subject to change without notice.

The specification for bearing type is for reference only , for more bearing types information, please contact 網頁上呈現產品軸承資訊均以2Ball為主

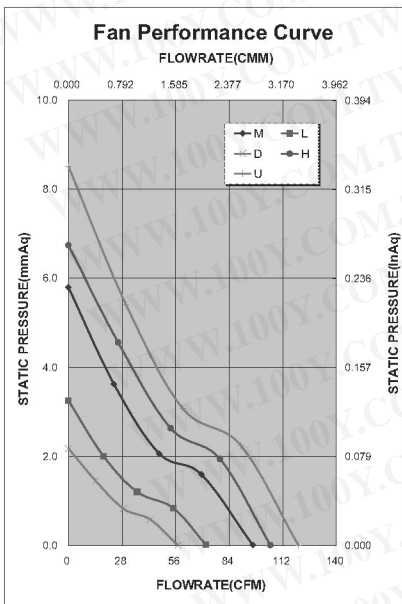

*Motor protective circuit and third lead wire functions

0	1	2	3	4	6	7	8	9	A	B
✓	✓	✓	✓	✓	✓					

*Safety approvals

✓	✓		✓	✓