

AC FAN SK825AP 80 X 80 X 26mm(3") 19~10 CFM

勝特力電材超市-龍山店 886-3-5773766
 勝特力電材超市-光復店 886-3-5729570
 勝特力電子(上海) 86-21-34970699
 勝特力電子(深圳) 86-755-83298787
<http://www.100y.com.tw>

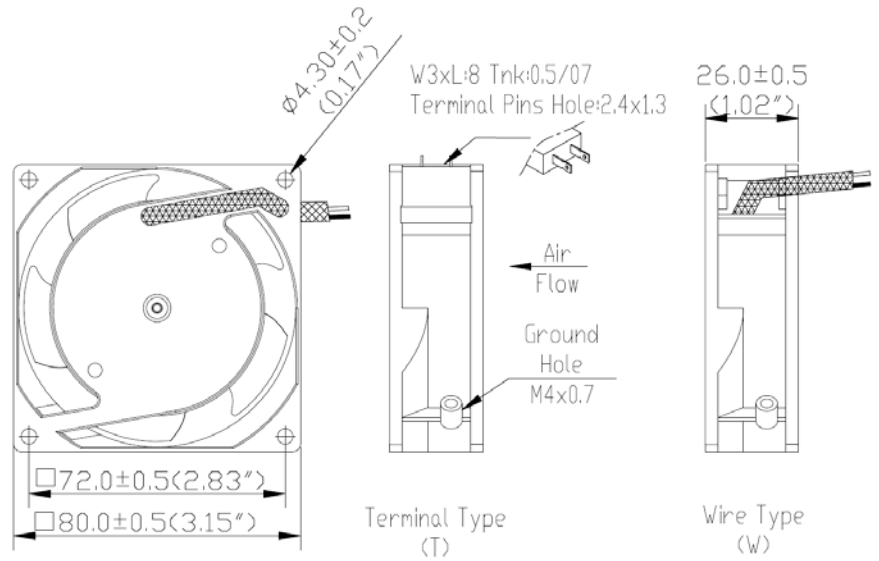

- 馬達 Motor: Shaded pole, impedance protected
- 外殼 Housing / Frame: Die-cast aluminum, Painted black (AP)
- 風葉 Impeller: PBT thermoplastic + glass fiber, UL 94V-0
- 軸承 Bearing Type: Two-ball or sleeve available
- 接電方式 Connecting: T-Terminal push-on type or W-Lead wire type
- 耐壓 Dielectric Strength: 1 min. at 1,500VAC, 50/60Hz
- 溫度範圍 Operating Temp: Ball bearing -20°C~+70°C; Sleeve bearing -10°C~+55°C
- 壽命 Life Expectancy: Ball bearing 60,000 hours at 60°C; Sleeve bearing 20,000 hours at 45°C
- 淨重 Net Weight: 260gm(0.57 pound)
- 檢定 Safety Approvals: UL, CUL, TUV, CE, RoHS

SK825 P-Q Curves

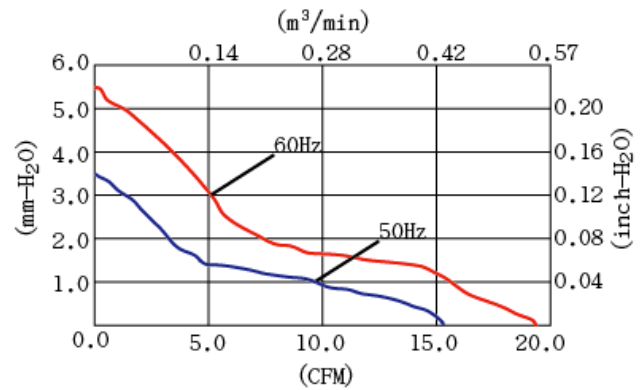

型號 Model No.	電壓 Rated VAC	頻率 Freq. Hz	電流 Rated Input Amp	功率 Rated Input Watt	轉速 Rated Speed RPM	最大風量 Max. Air Flow		最大風壓 Max. Static Pressure		噪音 Noise Level (dB)
						m³/min	CFM	mm-H ₂ O	inch-H ₂ O	
SK825AP-11-1	110 (100V~120V)	50/60	0.17/0.15	15/13	2550/3200	0.42/0.54	15/19	3.5/5.5	0.14/0.22	27/34
SK825AP-11-2	110 (100V~120V)	50/60	0.09/0.08	10/9	2100/2550	0.34/0.42	12/15	2.1/2.8	0.08/0.11	27/29
SK825AP-11-3	110 (100V~120V)	50/60	0.07/0.06	7/6	1750/1850	0.28/0.34	10/12	1.5/1.6	0.06/0.06	25/30
SK825AP-22-1	220 (200V~240V)	50/60	0.08/0.07	15/13	2550/3200	0.42/0.54	15/19	3.5/5.5	0.14/0.22	27/35
SK825AP-22-2	220 (200V~240V)	50/60	0.06/0.05	10/9	2400/2950	0.40/0.51	14/18	2.9/4.3	0.11/0.17	23/24