



Features

- Compact design to save board space - 0805 footprint
- Small size results in very fast time to react to fault events
- Symmetrical design
- Low profile
- RoHS compliant* and halogen free**
- Agency recognition: 

Applications

- USB port protection - USB 2.0, 3.0 & OTG
- HDMI 1.4 Source protection
- PC motherboards - Plug and Play protection
- Mobile phones - Battery and port protection
- PDAs / digital cameras
- Game console port protection

MF-PSMF Series - PTC Resettable Fuses

Electrical Characteristics

Model	V max. Volts	I max. Amps	I _{hold}	I _{trip}	Resistance		Max. Time To Trip		Tripped Power Dissipation
			Amperes at 23 °C		Ohms at 23 °C		Amperes at 23 °C	Seconds at 23 °C	Watts at 23 °C
			Hold	Trip	R _{Min.}	R _{1Max.}			Typ.
MF-PSMF010X	15	40	0.10	0.30	1.0	7.5	0.5	1.5	0.5
MF-PSMF020X	9	40	0.20	0.50	0.65	3.5	8.00	0.02	0.5
MF-PSMF035X	6	40	0.35	0.75	0.250	1.200	8.00	0.10	0.5
MF-PSMF050X	6	40	0.50	1.00	0.150	0.900	8.00	0.10	0.5
MF-PSMF075X	6	40	0.75	1.50	0.090	0.350	8.00	0.20	0.6
MF-PSMF110X	6	40	1.10	2.20	0.060	0.210	8.00	0.30	0.6

Environmental Characteristics

Operating Temperature.....	-40 °C to +85 °C	
Maximum Device Surface Temperature in Tripped State	125 °C	
Passive Aging.....	+85 °C, 1000 hours..... ±5 % typical resistance change	
Humidity Aging.....	+85 °C, 85 % R.H. 1000 hours	±5 % typical resistance change
Thermal Shock.....	+85 °C to -40 °C, 20 times.....	±10 % typical resistance change
Solvent Resistance.....	MIL-STD-202, Method 215	No change
Vibration	MIL-STD-883C, Method 2007.1.....	No change
	Condition A	

勝特力材料 886-3-5753170
 勝特力电子(上海) 86-21-34970699
 勝特力电子(深圳) 86-755-83298787
[Http://www.100y.com.tw](http://www.100y.com.tw)

Test Procedures And Requirements For Model MF-PSMF Series

Test	Test Conditions	Accept/Reject Criteria
Visual/Mech.....	Verify dimensions and materials.....	Per MF physical description
Resistance.....	In still air @ 23 °C.....	R _{min} ≤ R ≤ R _{1max}
Time to Trip.....	At specified current, V _{max} , 23 °C.....	T ≤ max. time to trip (seconds)
Hold Current.....	30 min. at I _{hold}	No trip
Trip Cycle Life.....	V _{max} , I _{max} , 100 cycles.....	No arcing or burning
Trip Endurance.....	V _{max} , 48 hours.....	No arcing or burning
Solderability.....	ANSI/J-STD-002.....	95 % min. coverage

UL File Number..... E174545
<http://www.ul.com/> Follow link to Certifications, then UL File No., enter E174545

TÜV Certificate Number R 50171531
<http://www.tuvdotcom.com/> Follow link to "other certificates", enter File No. 50171531

Thermal Derating Chart - I_{hold} (Amps)

Model	Ambient Operating Temperature								
	-40 °C	-20 °C	0 °C	23 °C	40 °C	50 °C	60 °C	70 °C	85 °C
MF-PSMF010X	0.15	0.13	0.12	0.10	0.09	0.08	0.07	0.06	0.05
MF-PSMF020X	0.28	0.25	0.23	0.20	0.17	0.14	0.12	0.10	0.07
MF-PSMF035X	0.47	0.44	0.39	0.35	0.30	0.27	0.24	0.20	0.14
MF-PSMF050X	0.68	0.62	0.55	0.50	0.40	0.37	0.33	0.29	0.23
MF-PSMF075X	1.00	0.90	0.79	0.75	0.63	0.57	0.53	0.42	0.35
MF-PSMF110X	1.45	1.35	1.20	1.10	0.92	0.84	0.75	0.65	0.52

*RoHS Directive 2002/95/EC Jan. 27, 2003 including annex and RoHS Recast 2011/65/EU June 8, 2011.

**Bourns follows the prevailing definition of "halogen free" in the industry. Bourns considers a product to be "halogen free" if (a) the Bromine (Br) content is 900 ppm or less; (b) the Chlorine (Cl) content is 900 ppm or less; and (c) the total Bromine (Br) and Chlorine (Cl) content is 1500 ppm or less.

Specifications are subject to change without notice.

The device characteristics and parameters in this data sheet can and do vary in different applications and actual device performance may vary over time. Users should verify actual device performance in their specific applications.

Additional Applications

- Automotive electronic control modules

MF-PSMF Series - PTC Resettable Fuses

BOURNS®

Product Dimensions

Model	A		B		C		D
	Min.	Max.	Min.	Max.	Min.	Max.	Min.
MF-PSMF010X	2.00 (0.079)	2.30 (0.091)	1.20 (0.047)	1.50 (0.059)	0.48 (0.019)	0.85 (0.033)	0.20 (0.008)
MF-PSMF020X	2.00 (0.079)	2.30 (0.091)	1.20 (0.047)	1.50 (0.059)	0.48 (0.019)	0.85 (0.033)	0.20 (0.008)
MF-PSMF035X	2.00 (0.079)	2.30 (0.091)	1.20 (0.047)	1.50 (0.059)	0.48 (0.019)	0.85 (0.033)	0.20 (0.008)
MF-PSMF050X	2.00 (0.079)	2.30 (0.091)	1.20 (0.047)	1.50 (0.059)	0.48 (0.019)	0.85 (0.033)	0.20 (0.008)
MF-PSMF075X	2.00 (0.079)	2.30 (0.091)	1.20 (0.047)	1.50 (0.059)	0.75 (0.030)	1.25 (0.049)	0.20 (0.008)
MF-PSMF110X	2.00 (0.079)	2.30 (0.091)	1.20 (0.047)	1.50 (0.059)	0.75 (0.030)	1.25 (0.049)	0.20 (0.008)

Packaging: 3000 pcs. per reel.

DIMENSIONS: $\frac{\text{MM}}{\text{(INCHES)}}$

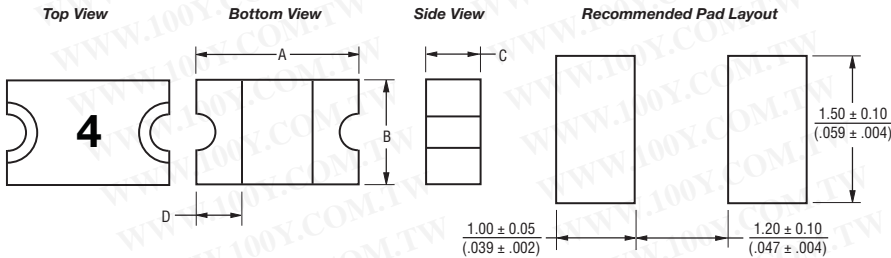

Terminal material:
Nickel/gold plated.

Termination pad solderability:
Standard Au finish:
Meets ANSI/J-STD-002 Category 2.

Recommended Storage:
40 °C max./70 % RH max.

Typical Time to Trip at 23 °C

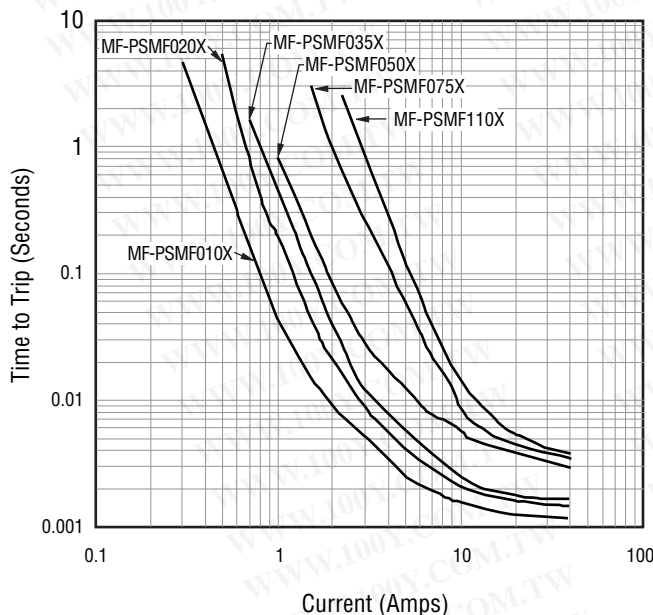

The Time to Trip curves represent typical performance of a device in a simulated application environment. Actual performance in specific customer applications may differ from these values due to the influence of other variables.

How to Order

MF - PSMF 050 X - 2

Multifuse® Product Designator _____
 Series _____
 PSMF = 0805 Surface Mount Component
 Hold Current, Ihold _____
 010-110 (0.10 - 1.10 Amps)
 Multifuse® freeXpansion™ Design _____
 Packaging _____
 Packaged per EIA 481-1
 -2 = Tape and Reel

Typical Part Marking

Represents total content. Layout may vary.

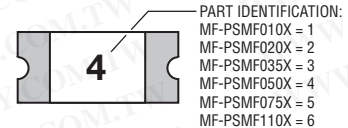

BIWEEKLY DATE CODE WILL APPEAR ON THE PACKAGING LABEL:
 WEEK 1 AND 2 = A
 WEEK 51 AND 52 = Z

Specifications are subject to change without notice. The device characteristics and parameters in this data sheet can and do vary in different applications and actual device performance may vary over time. Users should verify actual device performance in their specific applications.

MF-PSMF Series - PTC Resettable Fuses

BOURNS®

Solder Reflow Recommendations

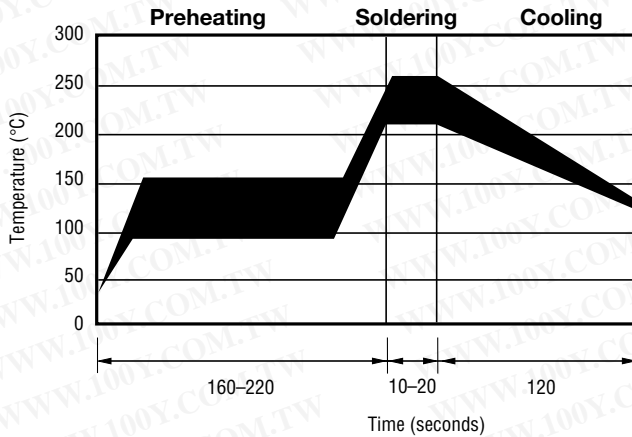

Notes:

- MF-NSMF models cannot be wave soldered. Please contact Bourns for hand soldering recommendations.
- If reflow temperatures exceed the recommended profile, devices may not meet the performance requirements.
- Compatible with Pb and Pb-free solder reflow profiles.
- Excess solder may cause a short circuit, especially during hand soldering. Please refer to the Multifuse® Polymer PTC Soldering Recommendation guidelines.

MF-PSMF SERIES, REV. N 08/15

“freeXpansion Design” is a trademark of Bourns, Inc.

Specifications are subject to change without notice.

The device characteristics and parameters in this data sheet can and do vary in different applications and actual device performance may vary over time. Users should verify actual device performance in their specific applications.

勝特力材料 886-3-5753170
 勝特力电子(上海) 86-21-34970699
 勝特力电子(深圳) 86-755-83298787
[Http://www.100y.com.tw](http://www.100y.com.tw)

MF-PSMF Series Tape and Reel Specifications

BOURNS®

Tape Dimensions	MF-PSMF010X, MF-PSMF020X, MF-PSMF035X & MF-PSMF050X per EIA 481-1	MF-PSMF075X & MF-PSMF110X per EIA 481-1
W	$\frac{8.0 - 0.30}{(0.315 - 0.012)}$	$\frac{8.0 - 0.30}{(0.315 - 0.012)}$
P ₀	$\frac{4.0 - 0.10}{(0.157 - 0.004)}$	$\frac{4.0 - 0.10}{(0.157 - 0.004)}$
P ₁	$\frac{4.0 - 0.10}{(0.157 - 0.004)}$	$\frac{4.0 - 0.10}{(0.157 - 0.004)}$
P ₂	$\frac{2.0 - 0.05}{(0.079 - 0.002)}$	$\frac{2.0 - 0.05}{(0.079 - 0.002)}$
A ₀	$\frac{1.65 - 0.10}{(0.065 - 0.004)}$	$\frac{1.65 - 0.10}{(0.065 - 0.004)}$
B ₀	$\frac{2.4 - 0.10}{(0.094 - 0.004)}$	$\frac{2.4 - 0.10}{(0.094 - 0.004)}$
B ₁ max.	$\frac{4.35}{(0.171)}$	$\frac{4.35}{(0.171)}$
D ₀	$\frac{1.50 + 0.10/-0.0}{(0.059 + 0.004/-0)}$	$\frac{1.50 + 0.10/-0.0}{(0.059 + 0.004/-0)}$
F	$\frac{3.5 - 0.05}{(0.138 + 0.002)}$	$\frac{3.5 - 0.05}{(0.138 + 0.002)}$
E ₁	$\frac{1.75 - 0.10}{(0.069 - 0.004)}$	$\frac{1.75 - 0.10}{(0.069 - 0.004)}$
E ₂ min.	$\frac{6.25}{(0.246)}$	$\frac{6.25}{(0.246)}$
T max.	$\frac{0.6}{(0.024)}$	$\frac{0.6}{(0.024)}$
T ₁ max.	$\frac{0.10}{(0.004)}$	$\frac{0.10}{(0.004)}$
K ₀	$\frac{0.95 - 0.10}{(0.037 - 0.004)}$	$\frac{1.25 - 0.10}{(0.049 - 0.004)}$
Leader min.	$\frac{390}{(15.35)}$	$\frac{390}{(15.35)}$
Trailer min.	$\frac{160}{(6.30)}$	$\frac{160}{(6.30)}$
Reel Dimensions		
A max.	$\frac{185}{(7.28)}$	$\frac{185}{(7.28)}$
N min.	$\frac{50}{(1.97)}$	$\frac{50}{(1.97)}$
W ₁	$\frac{8.4 + 1.5/-0.0}{(0.331 + 0.059/-0)}$	$\frac{8.4 + 1.5/-0.0}{(0.331 + 0.059/-0)}$
W ₂ max.	$\frac{14.4}{(0.567)}$	$\frac{14.4}{(0.567)}$

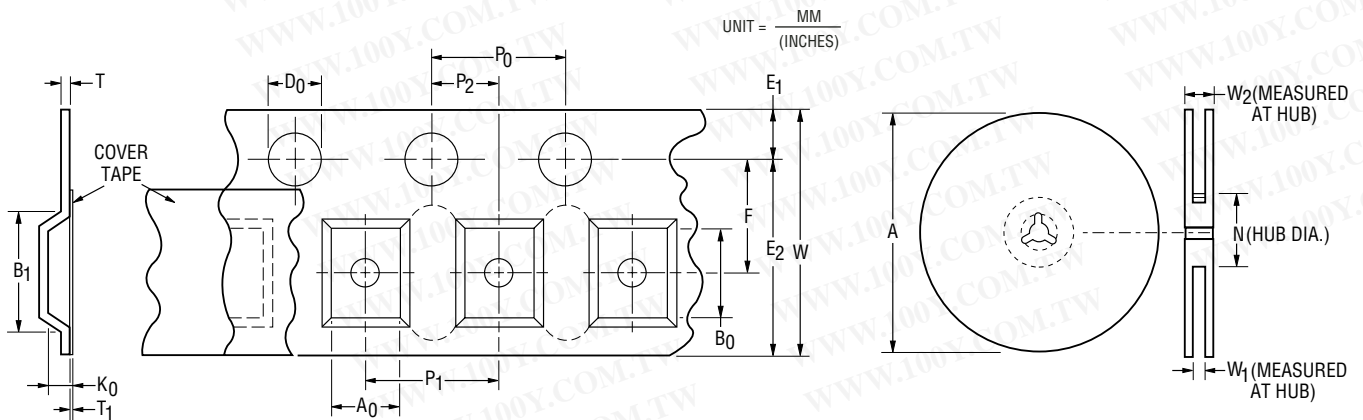

Specifications are subject to change without notice.
 Customers should verify actual device performance in their specific applications.