

Dual Display PID Temperature Controllers

TCN Series

INSTRUCTION MANUAL

TCD210225AB

Autonics

Thank you for choosing our Autonics product.

Read and understand the instruction manual and manual thoroughly before using the product.

For your safety, read and follow the below safety considerations before using.

For your safety, read and follow the considerations written in the instruction manual, other manuals and Autonics website.

Keep this instruction manual in a place where you can find easily.

The specifications, dimensions, etc are subject to change without notice for product improvement Some models may be discontinued without notice.

Follow Autonics website for the latest information.

Safety Considerations

- Observe all 'Safety Considerations' for safe and proper operation to avoid hazards.
- ⚠ symbol indicates caution due to special circumstances in which hazards may occur.

⚠ Warning Failure to follow instructions may result in serious injury or death

01. Fail-safe device must be installed when using the unit with machinery that may cause serious injury or substantial economic loss.(e.g. nuclear power control, medical equipment, ships, vehicles, railways, aircraft, combustion apparatus, safety equipment, crime/disaster prevention devices, etc.)

Failure to follow this instruction may result in personal injury, economic loss or fire.

02. Do not use the unit in the place where flammable/explosive/corrosive gas, high humidity, direct sunlight, radiant heat, vibration, impact or salinity may be present.

Failure to follow this instruction may result in explosion or fire.

03. Install on a device panel to use.

Failure to follow this instruction may result in fire or electric shock.

04. Do not connect, repair, or inspect the unit while connected to a power source.

Failure to follow this instruction may result in fire or electric shock.

05. Check 'Connections' before wiring.

Failure to follow this instruction may result in fire.

06. Do not disassemble or modify the unit.

Failure to follow this instruction may result in fire or electric shock.

⚠ Caution Failure to follow instructions may result in injury or product damage

01. When connecting the power input and relay output, use AWG 20 (0.50 mm²) cable or over, and tighten the terminal screw with a tightening torque of 0.74 to 0.90 N m.

When connecting the sensor input and communication cable without dedicated cable, use AWG 28 to 16 cable and tighten the terminal screw with a tightening torque of 0.74 to 0.90 N m.

Failure to follow this instruction may result in fire or malfunction due to contact failure.

02. Use the unit within the rated specifications.

Failure to follow this instruction may result in fire or product damage

03. Use a dry cloth to clean the unit, and do not use water or organic solvent.

Failure to follow this instruction may result in fire or electric shock.

04. Keep the product away from metal chip, dust, and wire residue which flow into the unit.

Failure to follow this instruction may result in fire or product damage.

Cautions during Use

- Follow instructions in 'Cautions during Use'. Otherwise, it may cause unexpected accidents.
- Check the polarity of the terminals before wiring the temperature sensor.
- For RTD temperature sensor, wire it as 3-wire type, using cables in same thickness and length. For thermocouple (TC) temperature sensor, use the designated compensation wire for extending wire.
- Keep away from high voltage lines or power lines to prevent inductive noise. In case installing power line and input signal line closely, use line filter or varistor at power line and shielded wire at input signal line. Do not use near the equipment which generates strong magnetic force or high frequency noise.
- Install a power switch or circuit breaker in the easily accessible place for supplying or disconnecting the power.
- Do not use the unit for other purpose (e.g. voltmeter, ammeter), but temperature controller.
- When changing the input sensor, turn off the power first before changing. After changing the input sensor, modify the value of the corresponding parameter.
- 24 VAC~, 24-48 VDC≒ power supply should be insulated and limited voltage/current or Class 2, SELV power supply device.
- Make a required space around the unit for radiation of heat. For accurate temperature measurement, warm up the unit over 20 min after turning on the power.
- Make sure that power supply voltage reaches to the rated voltage within 2 sec after supplying power.
- Do not wire to terminals which are not used.
- This unit may be used in the following environments.
 - Indoors (in the environment condition rated in 'Specifications')
 - Altitude Max. 2,000 m
 - Pollution degree 2
 - Installation category II

Ordering Information

This is only for reference, the actual product does not support all combinations. For selecting the specified model, follow the Autonics website .

T C N ① ② - ③ ④ ⑤ - ⑥

① Digit

4: 4 digit

② Size

S: DIN W 48 × H 48 mm
M: DIN W 72 × H 72 mm
H: DIN W 48 × H 96 mm
L: DIN W 96 × H 96 mm

③ Option in/output

2: Alarm 1/2

④ Power supply

2: 24 VAC~ 50/60 Hz, 24-48 VDC≒
4: 100-240 VAC~ 50/60 Hz

⑤ Control output

R: Relay
S: SSR drive

⑥ Wiring type

No mark: Bolt
P: Connector plug connection

Product Components

- Product (+ bracket)
- Instruction manual

Sold Separately

- Terminal protection cover: RSA / RMA / RHA / RLA-COVER

Specifications

Series	TCN4□-22□-□	TCN4□-24□-□
Power supply	24 VAC~ 50/60 Hz 24-48 VDC≒	100-240 VAC~ 50/60 Hz
Permissible voltage range	90 to 110 % of rated voltage	
Power consumption	AC: ≤ 5 VA, DC: ≤ 3 W	≤ 5 VA
Sampling period	100 ms	
Input specification	Refer to 'Input Type and Using Range.'	
Control output	Relay SSR	250 VAC~ 3A, 30 VDC≒ 3A, 1a 12 VDC≒ ±2 V, ≤ 20 mA
Alarm output	250 VAC~ 1 A 1a	
Display type	7 Segment (red, green), LED type	
Control type	Heating, Cooling	ON/OFF, P, PI, PD, PID Control
Hysteresis	1 to 100 (0.1 to 50.0) °C/°F	
Proportional band (P)	0.1 to 999.9 °C/°F	
Integral time (I)	0 to 9,999 sec	
Derivative time (D)	0 to 9,999 sec	
Control cycle (T)	0.5 to 120.0 sec	
Manual reset	0.0 to 100.0%	
Relay life cycle	Mechanical Electrical	≥ 5,000,000 operations OUT1/2: ≥ 200,000 operations (load resistance: 250 VAC~ 3 A) AL1/2: ≥ 300,000 operations (load resistance: 250 VAC~ 1 A)
Dielectric strength	Between the charging part and the case: 1,000 VAC~ 50/60 Hz for 1 min	Between the charging part and the case: 2,000 VAC~ 50/60 Hz for 1 min
Vibration	0.75 mm amplitude at frequency of 5 to 55 Hz in each X, Y, Z direction for 2 hours	
Insulation resistance	≥ 100 MΩ (500 VDC≒ megger)	
Noise immunity	±2 kV square shaped noise (pulse width: 1 μs) by noise simulator R-phase, S-phase	
Memory retention	≈ 10 years (non-volatile semiconductor memory type)	
Ambient temperature	-10 to 50 °C, storage: -20 to 60 °C (no freezing or condensation)	
Ambient humidity	35 to 85%RH, storage: 35 to 85%RH (no freezing or condensation)	
Insulation type	Mark: □, double or reinforced insulation (dielectric strength between the measuring input part and the power part: 1 kV)	Mark: □, double or reinforced insulation (dielectric strength between the measuring input part and the power part: 2 kV)
Certification	CE, RoHS, REACH, ENEC	
Unit weight (packaged)	• TCN4S: ≈ 100 g (≈ 147 g) • TCN4H: ≈ 124 g (≈ 194 g)	• TCN4M: ≈ 133 g (≈ 203 g) • TCN4L: ≈ 179 g (≈ 275 g)

勝特力電材超市-龍山店 886-3-5773766
勝特力電材超市-光復店 886-3-5729570
勝特力电子(上海) 86-21-34970699
勝特力电子(深圳) 86-755-83298787
http://www.100y.com.tw

Input Type and Using Range

The setting range of some parameters is limited when using the decimal point display.

Input type	Decimal point	Display	Using range (°C)	Using range (°F)	
Thermo-couple	K (CA)	1	ℰℰRH	-50 to 1,200	-58 to 2,192
		0.1	ℰℰRL	-50.0 to 999.9	-58.0 to 999.9
	J (IC)	1	JℰLH	-30 to 800	-22 to 1,472
		0.1	JℰLL	-30.0 to 800.0	-22.0 to 999.9
	L (IC)	1	LℰLH	-40 to 800	-40 to 1,472
		0.1	LℰLL	-40.0 to 800.0	-40.0 to 999.9
T (CC)	1	ℰℰℰH	-50 to 400	-58 to 752	
		ℰℰℰL	-50.0 to 400.0	-58.0 to 752.0	
	0.1	ℰℰℰH	0 to 1,700	32 to 3,092	
		ℰℰℰL	0 to 1,700	32 to 3,092	
RTD	Cu50 Ω	1	ℰℰSH	-50 to 200	-58 to 392
		0.1	ℰℰSL	-50.0 to 200.0	-58.0 to 392.0
	DPT100 Ω	1	dPEH	-100 to 400	-148 to 752
		0.1	dPEL	-100.0 to 400.0	-148.0 to 752.0

■ Display accuracy

Input type	Using temperature	Display accuracy
Thermocouple RTD	At room temperature (23°C ±5 °C)	(PV ±0.5% or ±1 °C higher one) ±1-digit • Thermocouple R, S below 200 °C: (PV ±0.5% or ±3 °C higher one) ±1-digit Over 200 °C: (PV ±0.5% or ±2 °C higher one) ±1digit • Thermocouple L, RTD Cu50 Ω: (PV ±0.5% or ±2 °C higher one) ±1-digit
	Out of room temperature range	(PV ±0.5% or ±2 °C higher one) ±1-digit • Thermocouple R, S below 200 °C: (PV ±1.0% or ±6 °C higher one) ±1digit Over 200 °C: (PV ±0.5% or ±5 °C higher one) ±1digit • Thermocouple L, RTD Cu50 Ω: (PV ±0.5% or ±3 °C higher one) ±1digit

- For TCN4S-□-P, add ±1°C by accuracy standard.
- If the input specification is set to 'decimal point 0.1' display, add ±1°C by accuracy standard.

Unit Descriptions

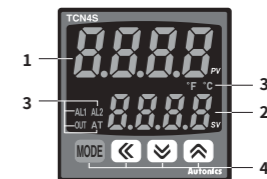

1. PV Display part (red)

- RUN mode: Displays PV (Present value)

- Setting mode: Displays parameter name

2. SV Display part (green)

- RUN mode: Displays SV (Setting value)

- Setting mode: Displays parameter setting value

3. Indicator

Display	Name	Description
AL1/2	Alarm output	Turns ON when the alarm output is ON.
OUT	Control output	Turns ON when control output is ON • CYCLE/PHASE control of SSR drive output: Turns ON when MV is over 3.0% [AC power model]
AT	Auto tuning	Flashes during auto tuning every 1 sec
°C, %, °F	Unit	Displays selected unit (parameter).

4. Input key

Display	Name
[MODE]	Mode key
[◀], [▼], [▲]	Setting value control key

Errors

Display	Description	Troubleshooting
oPEo	Flashes when input sensor is disconnected or sensor is not connected.	Check input sensor status.
HHHH	Flashes when PV is higher than input range. ^[01]	When input is within the rated input range, this display disappears.
LLLL	Flashes when PV is lower than input range. ^[01]	

[01] Be careful that when HHHH / LLLLL error occurs, the control output may occur by recognizing the maximum or minimum input depending on the control type.

Dimensions

- Unit: mm, For the detailed drawings, follow the Autonics website.
- Below is based on TCN4S Series.

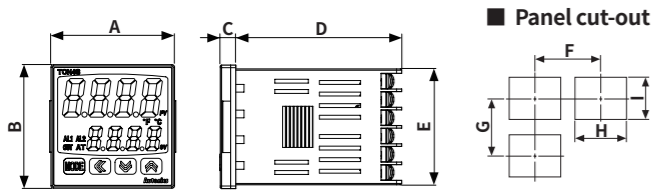

Panel cut-out

	Body				Panel cut-out				
	A	B	C	D	E	F	G	H	I
TCN4S	48	48	6	64.5	44.8	≥ 65	≥ 65	45 ^{+0.5} ₀	45 ^{+0.5} ₀
TCN4S-P	48	48	7.7	65.8	44.8	≥ 65	≥ 65	45 ^{+0.5} ₀	45 ^{+0.5} ₀
TCN4M	72	72	6	64.5	67.5	≥ 90	≥ 90	68 ^{+0.7} ₀	68 ^{+0.7} ₀
TCN4H	48	96	6	64.5	91.5	≥ 65	≥ 115	45 ^{+0.6} ₀	92 ^{+0.8} ₀
TCN4L	96	96	6	64.5	91.5	≥ 115	≥ 115	92 ^{+0.8} ₀	92 ^{+0.8} ₀

Bracket

TCN4S

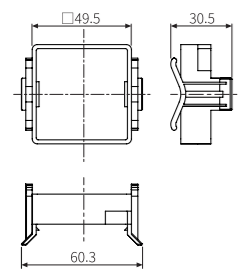

Other series

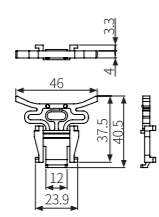

Installation Method

TCN4S

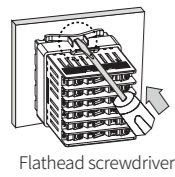

Flathead screwdriver

Other series

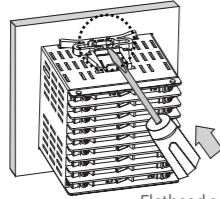

Flathead screwdriver

Insert the unit into a panel, fasten the bracket by pushing with a flathead screwdriver.

Crimp Terminal Specifications

- Unit: mm, Use the crimp terminal of follow shape.

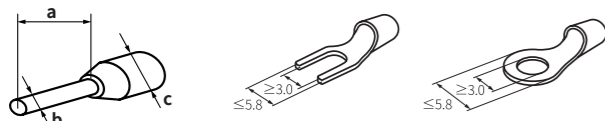

Wire ferrule

Terminal number	a	b	c
1 to 8	6	≤ 1.7	≤ 3.7
9 to 11	6 to 8	≤ 2.1	≤ 4.2
12 to 14	6 to 8	≤ 1.5	≤ 3.5

Fork crimp terminal

Round crimp terminal

Connections

TCN4S

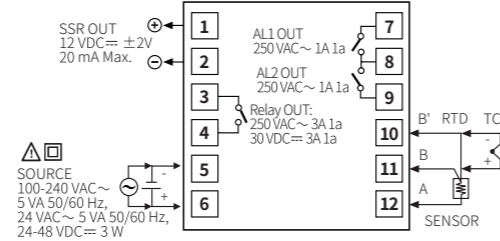

TCN4S-P

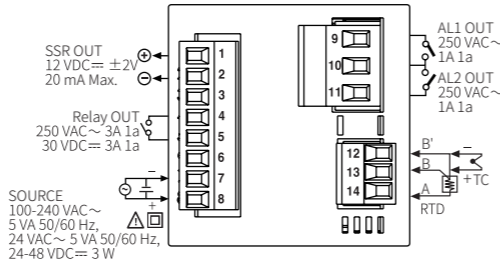

TCN4M

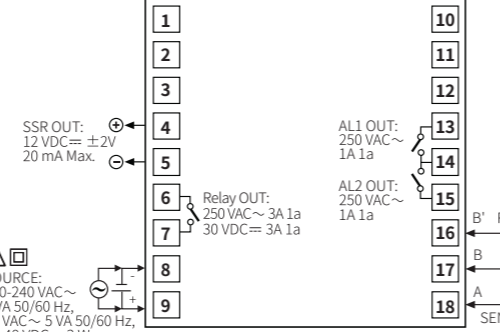

TCN4H/L

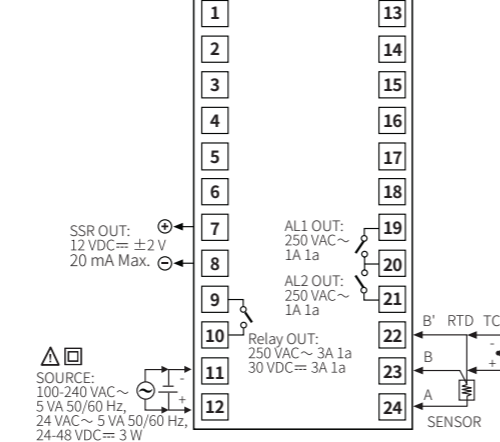

Mode Setting

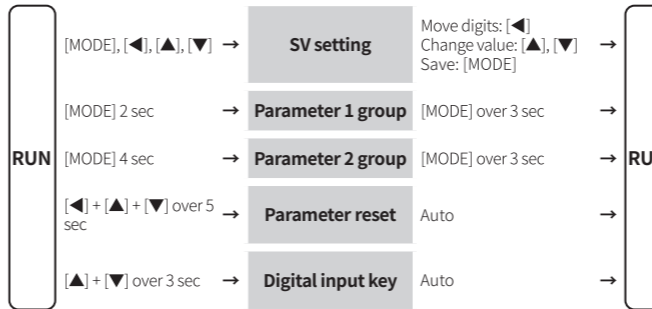

Parameter Setting

- Some parameters are activated/deactivated depending on the model or setting of other parameters. Refer to the description of each item.
- The setting range in parentheses is for using the decimal point display in the input specification.
- If there is no key input for more than 30 seconds in each parameter, it returns to RUN mode.
- When pressing the [MODE] key within 1 second after returning to the operation mode from the parameter group, it will enter the parameter group before returning.
- [MODE] key: Saves the current parameter setting value and moves to the next parameter.
- [◀] key: Checks the fixed item / Moves the row when changing the set value
- [▲], [▼] keys: Selects the parameter / Changes the set value
- Recommended parameter setting sequence: Parameter 2 group → Parameter 1 group → SV setting mode

Parameter 1 group

Parameter	Display	Default	Setting range	Condition
1-1 AL1 alarm temperature	RL 1	125.0	Deviation alarm: -F.S. to F.S. °C/°F Absolute value alarm: Within input range	2-12/14 alarm operation: AM1 to AM6
1-2 AL2 alarm temperature	RL 2	125.0		
1-3 Auto tuning	RL	OFF	OFF: Stop, ON: Execution	2-8 Control type: PID
1-4 Proportional band	P	10.0	0.1 to 999.9 °C/°F	
1-5 Integral time	I	0.000	0 (OFF) to 9999 sec	
1-6 Derivative time	d	0.000	0 (OFF) to 9999 sec	
1-7 Manual reset	r ESt	0.500	0.0 to 100.0%	2-8 Control type: PID & 1-5 Integral time: 0
1-8 Hysteresis	HYS	0.02	1 to 100 (0.1 to 50.0) °C/°F	2-8 Control type: ONOF

Parameter 2 group

Parameter	Display	Default	Setting range	Condition
2-1 Input specification ⁰¹⁾	Input	1 n - t	ℓ C RH	Refer to 'Input Type and Using Range'.
2-2 Temperature unit ⁰¹⁾	Unit t	°C	°C, °F	-
2-3 Input correction	Input	n - b	0000	-999 to 999 (-199.9 to 999.9) °C/°F
2-4 Input digital filter	Filter	n R w F	000.1	0.1 to 120.0 sec
2-5 SV low limit ⁰²⁾	L - Sv	- 5.0		Within 2-1 Input specification Input range, L-SV ≤ H-SV - 1-digit °C/°F H-SV ≥ L-SV + 1-digit °C/°F
2-6 SV high limit ⁰²⁾	H - Sv	120.0		
2-7 Control output mode ⁰³⁾	Control	o - Ft	HE RE	HEAT: Heating, COOL: Cooling
2-8 Control type ⁰⁴⁾	Control	C - nd	PI d	PID, ONOF: ON/OFF
2-9 Control output	Control	o Ut	r Ly	RLY: relay, SSR
2-10 SSR drive output type	SSR	5 Sr - n	5 t nd	[AC model] STND: standard, CYCL: cycle, PHAS: phase
2-11 Control cycle	Control	t	2.00	0.5 to 120.0 sec
2-12 AL1 alarm operation	AL1	RL - I	R n LR	□□□ AM0: Off AM1: Deviation high limit alarm AM2: Deviation low limit alarm AM3: Deviation high, low limit alarm AM4: Deviation high, low reverse alarm AM5: Absolute value high limit alarm AM6: Absolute value low limit alarm SBA: Sensor break alarm LBA: Loop break alarm (LBA)
2-13 AL1 alarm option	AL1	RL - I	□□□	A: Standard alarm B: Alarm latch C: Standby sequence 1 D: Alarm latch and standby sequence 1 E: Standby sequence 2 F: Alarm latch and standby sequence 2 • Enter to option setting: Press [◀] key in 2-12 AL-1 alarm operation.
2-14 AL2 alarm operation	AL2	RL - 2	R n 2R	Same as 2-12/13 AL1 alarm operation/option
2-15 AL2 alarm option	AL2	RL - 2	R n 2R	Same as 2-12/13 AL1 alarm operation/option
2-16 Alarm output hysteresis	Alarm	RHYSt	0.01	1 to 100 (0.1 to 50.0) °C/°F
2-17 LBA time	LBA	Lb RLt	0000	0 (OFF) to 9999 sec or auto (auto tuning)
2-18 LBA band	LBA	Lb Rb	0002	0 (OFF) to 999 (0.0 to 999.9) °C/°F or auto (auto tuning)
2-19 Digital input key	DI	d I - ℓ	St o P	STOP: Stop control output, AL.RE: Alarm reset, AT*: Auto tuning execution, OFF
2-20 Sensor error MV	SE	Er - n u	0000	0.0: OFF, 100.0: ON
2-21 Lock	Lock	L o C	o F F	OFF LOC1: Parameter 2 group lock LOC2: Parameter 1/2 group lock LOC3: Parameter 1/2 group, SV setting lock

01) Below parameters are initialized when the setting value is changed.
- Parameter 1 group: AL1/2 alarm temperature
- Parameter 2 group: Input correction, SV high/low limit, Alarm output hysteresis, LBA time, LBA band
- SV setting mode: SV

02) If SV is lower than low limit or higher than high limit when the value is changed, SV is changed to the low/high limit value.
If 2-1 Input specification is changed, the value is changed to Min./Max. value of Input specification.

03) When the setting value is changed, setting value of 2-20 Sensor error MV is initialized to 0.0 (OFF).

04) When changing the value from PID to ONOF, each value of following parameter is changed.
2-19 Digital input key: OFF, 2-20 Sensor error MV: 0.0 (when setting value is lower than 100.0)