

InGaAs PIN photodiode G8941 series

Sub-mount type photodiode for LD monitor

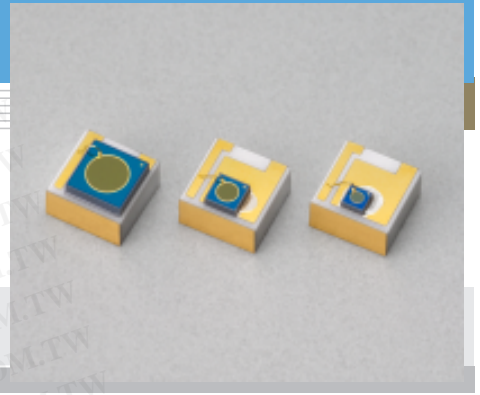

Features

- Active area
G8941-01: $\phi 1$ mm
G8941-02: $\phi 0.5$ mm
G8941-03: $\phi 0.3$ mm
- Miniature package: $2 \times 2 \times 1$ mm
- Precise chip position tolerance: ± 0.075 mm

Applications

- LD monitor

General rating

Parameter	G8941-01	G8941-02	G8941-03	Unit
Active area	$\phi 1$	$\phi 0.5$	$\phi 0.3$	mm

Absolute maximum ratings

Parameter	Symbol	Remark	G8941-01	G8941-02	G8941-03	Unit
Reverse voltage	V_R Max.		10	20	20	V
Operating temperature	T_{opr}	*	-40 to +85			$^{\circ}\text{C}$
Storage temperature	T_{stg}		-55 to +125			$^{\circ}\text{C}$

* In N_2 environment or in vacuum

Electrical and optical characteristics ($T_a = 25^{\circ}\text{C}$)

Parameter	Symbol	Condition	G8941-01			G8941-02			G8941-03			Unit
			Min.	Typ.	Max.	Min.	Typ.	Max.	Min.	Typ.	Max.	
Spectral response range	λ		0.9 to 1.7			0.9 to 1.7			0.9 to 1.7			μm
Photo sensitivity	S	$\lambda = 1.31 \mu\text{m}$	0.8	0.9	-	0.8	0.9	-	0.8	0.9	-	A/W
		$\lambda = 1.55 \mu\text{m}$	0.85	0.95	-	0.85	0.95	-	0.85	0.95	-	
Dark current	I_D	$V_R = 5 \text{ V}$	-	1	5	-	0.5	2.5	-	0.3	1.5	nA
Shunt resistance	R_{sh}	$V_R = 10 \text{ mV}$	-	100	-	-	300	-	-	1000	-	$\text{M}\Omega$
Terminal capacitance	C_t	$V_R = 5 \text{ V}$, $f = 1 \text{ MHz}$	-	90	-	-	12	-	-	5	-	pF
Cut-off frequency	f_c	$V_R = 5 \text{ V}$, $R_L = 50 \Omega$	-	35	-	-	200	-	-	400	-	MHz
Noise equivalent power	NEP	$\lambda = \lambda_p$	2×10^{-14}			8×10^{-15}			4×10^{-15}			$\text{W}/\text{Hz}^{1/2}$
Detectivity	D^*	$\lambda = \lambda_p$	5×10^{12}			5×10^{12}			5×10^{12}			$\text{cmHz}^{1/2}/\text{W}$

勝特力材料 886-3-5753170
 勝特力电子(上海) 86-21-34970699
 勝特力电子(深圳) 86-755-83298787
[Http://www.100y.com.tw](http://www.100y.com.tw)

■ Spectral response

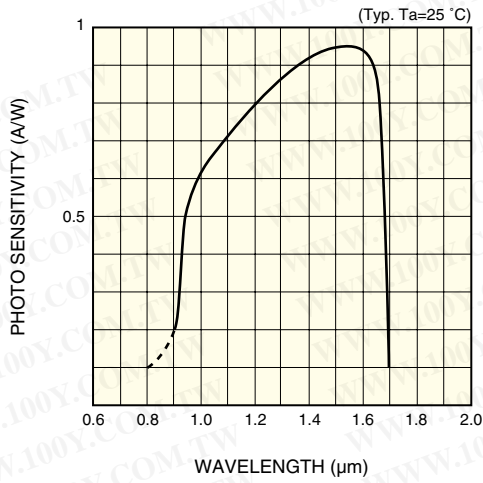

KIRDB0002EB

■ Dark current vs. reverse voltage

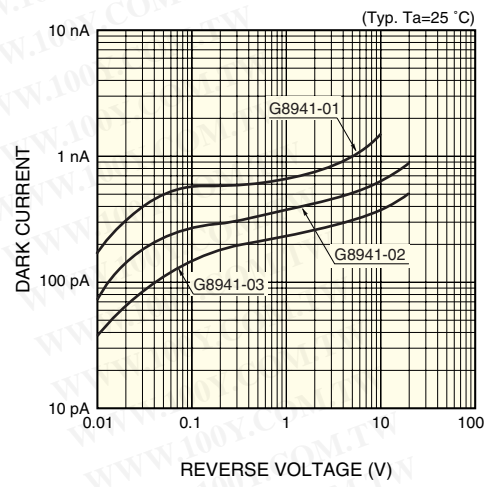

KIRDB0270EB

■ Terminal capacitance vs. reverse voltage

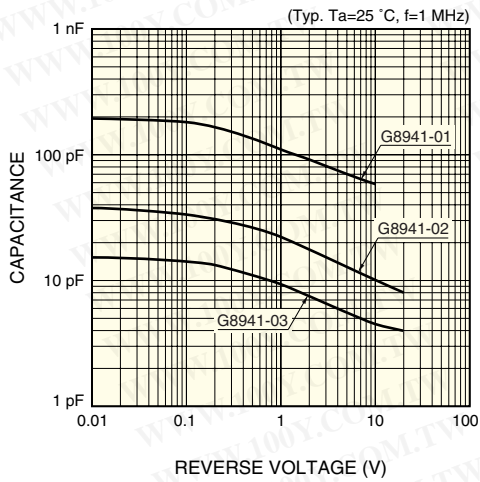

KIRDB0271EA

■ Dark current vs. temperature

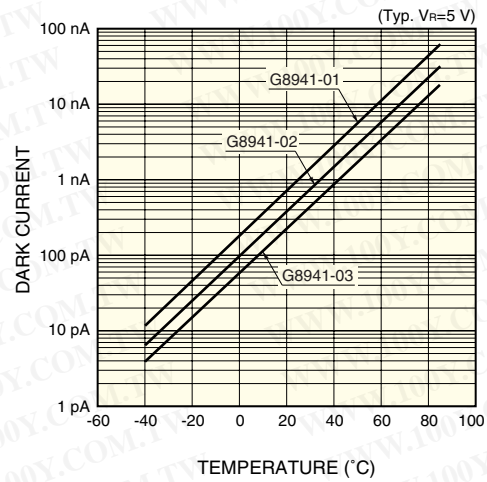

KIRDB0272EA

勝特力材料 886-3-5753170
 勝特力电子(上海) 86-21-34970699
 勝特力电子(深圳) 86-755-83298787
[Http://www.100y.com.tw](http://www.100y.com.tw)

Dimensional outline (unit: mm)

G8941-01

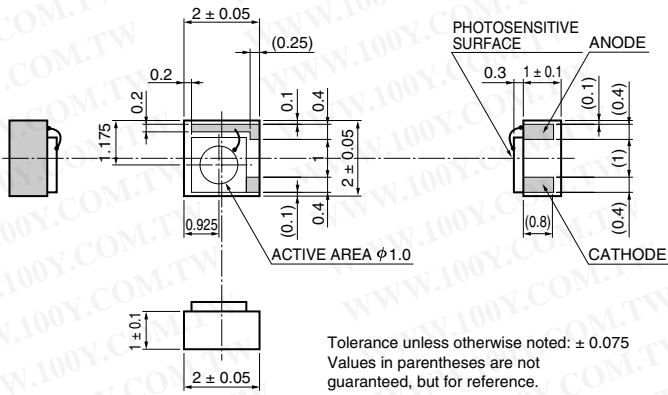

KIRDA0159EA

G8941-02

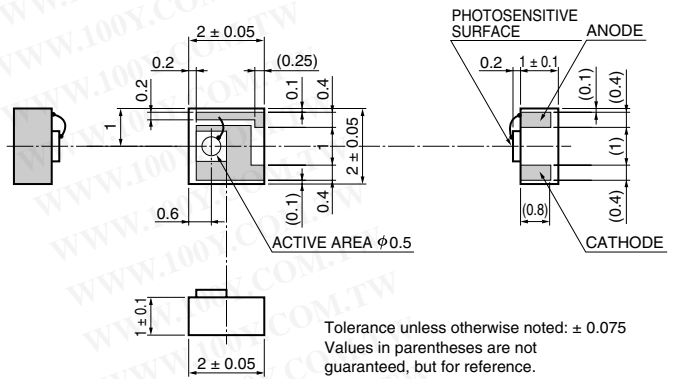

KIRDA0160EA

G8941-03

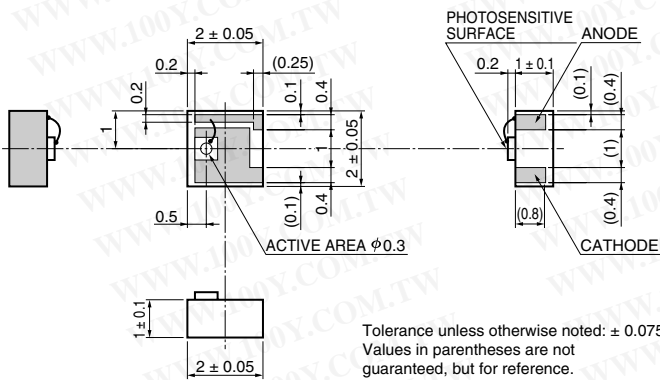

KIRDA0161EA

勝特力材料 886-3-5753170
 勝特力电子(上海) 86-21-34970699
 勝特力电子(深圳) 86-755-83298787
[Http://www.100y.com.tw](http://www.100y.com.tw)