



**FAIRCHILD™**

勝特力材料 886-3-5753170  
勝特力电子(上海) 86-21-34970699  
勝特力电子(深圳) 86-755-83298787  
[Http://www.100y.com.tw](http://www.100y.com.tw)



**ON Semiconductor®**

To learn more about ON Semiconductor, please visit our website at  
[www.onsemi.com](http://www.onsemi.com)

Please note: As part of the Fairchild Semiconductor integration, some of the Fairchild orderable part numbers will need to change in order to meet ON Semiconductor's system requirements. Since the ON Semiconductor product management systems do not have the ability to manage part nomenclature that utilizes an underscore (\_), the underscore (\_) in the Fairchild part numbers will be changed to a dash (-). This document may contain device numbers with an underscore (\_). Please check the ON Semiconductor website to verify the updated device numbers. The most current and up-to-date ordering information can be found at [www.onsemi.com](http://www.onsemi.com). Please email any questions regarding the system integration to [Fairchild\\_questions@onsemi.com](mailto:Fairchild_questions@onsemi.com).

ON Semiconductor and the ON Semiconductor logo are trademarks of Semiconductor Components Industries, LLC dba ON Semiconductor or its subsidiaries in the United States and/or other countries. ON Semiconductor owns the rights to a number of patents, trademarks, copyrights, trade secrets, and other intellectual property. A listing of ON Semiconductor's product/patent coverage may be accessed at [www.onsemi.com/site/pdf/Patent-Marking.pdf](http://www.onsemi.com/site/pdf/Patent-Marking.pdf). ON Semiconductor reserves the right to make changes without further notice to any products herein. ON Semiconductor makes no warranty, representation or guarantee regarding the suitability of its products for any particular purpose, nor does ON Semiconductor assume any liability arising out of the application or use of any product or circuit, and specifically disclaims any and all liability, including without limitation special, consequential or incidental damages. Buyer is responsible for its products and applications using ON Semiconductor products, including compliance with all laws, regulations and safety requirements or standards, regardless of any support or applications information provided by ON Semiconductor. "Typical" parameters which may be provided in ON Semiconductor data sheets and/or specifications can and do vary in different applications and actual performance may vary over time. All operating parameters, including "Typicals" must be validated for each customer application by customer's technical experts. ON Semiconductor does not convey any license under its patent rights nor the rights of others. ON Semiconductor products are not designed, intended, or authorized for use as a critical component in life support systems or any FDA Class 3 medical devices or medical devices with a same or similar classification in a foreign jurisdiction or any devices intended for implantation in the human body. Should Buyer purchase or use ON Semiconductor products for any such unintended or unauthorized application, Buyer shall indemnify and hold ON Semiconductor and its officers, employees, subsidiaries, affiliates, and distributors harmless against all claims, costs, damages, and expenses, and reasonable attorney fees arising out of, directly or indirectly, any claim of personal injury or death associated with such unintended or unauthorized use, even if such claim alleges that ON Semiconductor was negligent regarding the design or manufacture of the part. ON Semiconductor is an Equal Opportunity/Affirmative Action Employer. This literature is subject to all applicable copyright laws and is not for resale in any manner.



April 2015

# MCT5210M, MCT5211M 6-Pin DIP Low Input Current Phototransistor Optocouplers

## Features

- High  $CTR_{CE(SAT)}$  Comparable to Darlingtonts
- High Common Mode Transient Rejection: 5 kV/ $\mu$ s
- Data Rates Up to 150 kbits/s (NRZ)
- Safety and Regulatory Approvals:
  - UL1577, 4,170 VAC<sub>RMS</sub> for 1 Minute
  - DIN-EN/IEC60747-5-5, 850 V Peak Working Insulation Voltage

## Applications

- CMOS to CMOS/LSTTL Logic Isolation
- LSTTL to CMOS/LSTTL Logic Isolation
- RS-232 Line Receiver
- Telephone Ring Detector
- AC Line Voltage Sensing
- Switching Power Supply

## Description

The MCT5210M and MCT5211M devices consist of a high-efficiency AlGaAs infrared emitting diode coupled with an NPN phototransistor in a six-pin dual-in-line package.

The devices are well suited for CMOS to LSTTL/TTL interfaces, offering 250%  $CTR_{CE(SAT)}$  with 1 mA of LED input current. With an LED input current of 1.6 mA, data rates to 20K bits/s are possible.

Both can easily interface LSTTL to LSTTL/TTL, and with use of an external base-to-emitter resistor data rates of 100K bits/s can be achieved.

## Schematic

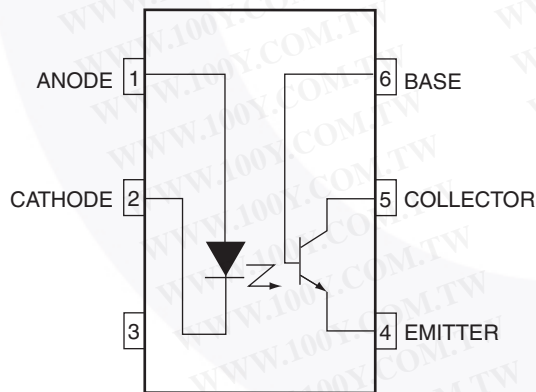

Figure 1. Schematic

## Package Outlines

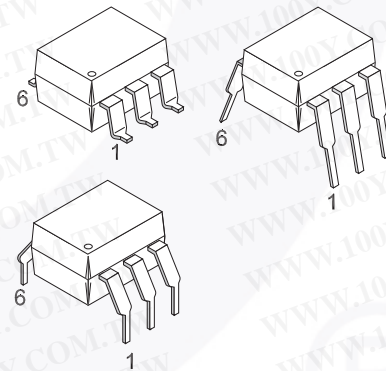

Figure 2. Package Outlines

MCT5210M, MCT5211M — 6-Pin DIP Low Input Current Phototransistor Optocouplers

## Safety and Insulation Ratings

As per DIN EN/IEC 60747-5-5, this optocoupler is suitable for “safe electrical insulation” only within the safety limit data. Compliance with the safety ratings shall be ensured by means of protective circuits.

Parameter		Characteristics
Installation Classifications per DIN VDE 0110/1.89 Table 1, For Rated Mains Voltage	< 150 V <sub>RMS</sub>	I–IV
	< 300 V <sub>RMS</sub>	I–IV
Climatic Classification		55/100/21
Pollution Degree (DIN VDE 0110/1.89)		2
Comparative Tracking Index		175

Symbol	Parameter	Value	Unit
V <sub>PR</sub>	Input-to-Output Test Voltage, Method A, V <sub>IORM</sub> × 1.6 = V <sub>PR</sub> , Type and Sample Test with t <sub>m</sub> = 10 s, Partial Discharge < 5 pC	1360	V <sub>peak</sub>
	Input-to-Output Test Voltage, Method B, V <sub>IORM</sub> × 1.875 = V <sub>PR</sub> , 100% Production Test with t <sub>m</sub> = 1 s, Partial Discharge < 5 pC	1594	V <sub>peak</sub>
V <sub>IORM</sub>	Maximum Working Insulation Voltage	850	V <sub>peak</sub>
V <sub>IOTM</sub>	Highest Allowable Over-Voltage	6000	V <sub>peak</sub>
	External Creepage	≥ 7	mm
	External Clearance	≥ 7	mm
	External Clearance (for Option TV, 0.4" Lead Spacing)	≥ 10	mm
DTI	Distance Through Insulation (Insulation Thickness)	≥ 0.5	mm
T <sub>S</sub>	Case Temperature <sup>(1)</sup>	175	°C
I <sub>S,INPUT</sub>	Input Current <sup>(1)</sup>	350	mA
P <sub>S,OUTPUT</sub>	Output Power <sup>(1)</sup>	800	mW
R <sub>IO</sub>	Insulation Resistance at T <sub>S</sub> , V <sub>IO</sub> = 500 V <sup>(1)</sup>	> 10 <sup>9</sup>	Ω

### Note:

1. Safety limit values – maximum values allowed in the event of a failure.

## Absolute Maximum Ratings

Stresses exceeding the absolute maximum ratings may damage the device. The device may not function or be operable above the recommended operating conditions and stressing the parts to these levels is not recommended. In addition, extended exposure to stresses above the recommended operating conditions may affect device reliability. The absolute maximum ratings are stress ratings only.

Symbol	Parameters	Value	Unit
<b>TOTAL DEVICE</b>			
T <sub>STG</sub>	Storage Temperature	-40 to +125	°C
T <sub>OPR</sub>	Operating Temperature	-40 to +100	°C
T <sub>J</sub>	Junction Temperature	-40 to +125	°C
T <sub>SOL</sub>	Lead Solder Temperature	260 for 10 seconds	°C
P <sub>D</sub>	Total Device Power Dissipation @ 25°C (LED plus detector)	225	mW
	Derate Linearly From 25°C	3.5	mW/°C
<b>EMITTER</b>			
I <sub>F</sub>	Continuous Forward Current	50	mA
V <sub>R</sub>	Reverse Input Voltage	6	V
I <sub>F(pk)</sub>	Forward Current – Peak (1 μs pulse, 300 pps)	3.0	A
P <sub>D</sub>	LED Power Dissipation @ 25°C	75	mW
	Derate Linearly From 25°C	1.0	mW/°C
<b>DETECTOR</b>			
I <sub>C</sub>	Continuous Collector Current	150	mA
P <sub>D</sub>	Detector Power Dissipation @ 25°C	150	mW
	Derate Linearly From 25°C	2.0	mW/°C



## Electrical Characteristics

$T_A = 25^\circ\text{C}$  unless otherwise specified.

### Individual Component Characteristics

Symbol	Parameters	Test Conditions	Min.	Typ.	Max.	Unit
<b>EMITTER</b>						
$V_F$	Input Forward Voltage	$I_F = 5\text{ mA}$		1.25	1.50	V
$\frac{\Delta V_F}{\Delta T_A}$	Forward Voltage Temperature Coefficient	$I_F = 2\text{ mA}$		-1.75		mV/°C
$V_R$	Reverse Voltage	$I_R = 10\ \mu\text{A}$	6			V
$C_J$	Junction Capacitance	$V_F = 0\text{ V}, f = 1.0\text{ MHz}$		18		pF
<b>DETECTOR</b>						
$BV_{CEO}$	Breakdown Voltage, Collector-to-Emitter	$I_C = 1.0\text{ mA}, I_F = 0$	30	100		V
$BV_{CBO}$	Breakdown Voltage, Collector-to-Base	$I_C = 10\ \mu\text{A}, I_F = 0$	30	120		V
$BV_{EBO}$	Breakdown Voltage, Emitter-to-Base	$I_E = 10\ \mu\text{A}, I_F = 0$	5	10		V
$I_{CER}$	Dark Current, Collector-to-Emitter	$V_{CE} = 10\text{ V}, I_F = 0, R_{BE} = 1\text{ M}\Omega$		1	100	nA
$C_{CE}$	Capacitance, Collector-to-Emitter	$V_{CE} = 0, f = 1\text{ MHz}$		10		pF
$C_{CB}$	Capacitance, Collector-to-Base	$V_{CB} = 0, f = 1\text{ MHz}$		80		pF
$C_{EB}$	Capacitance, Emitter-to-Base	$V_{EB} = 0, f = 1\text{ MHz}$		15		pF

**Electrical Characteristics** (Continued) $T_A = 25^\circ\text{C}$  unless otherwise specified.**Transfer Characteristics**

Symbol	Characteristics	Test Conditions	Device	Min.	Typ.	Max.	Unit
<b>DC CHARACTERISTICS</b>							
$CTR_{CE(SAT)}$	Saturated Current Transfer Ratio Collector-to-Emitter <sup>(2)</sup>	$I_F = 3.0\text{ mA}, V_{CE} = 0.4\text{ V}$	MCT5210M	60			%
		$I_F = 1.6\text{ mA}, V_{CE} = 0.4\text{ V}$	MCT5211M	100			%
		$I_F = 1.0\text{ mA}, V_{CE} = 0.4\text{ V}$		75			%
$CTR_{(CE)}$	Current Transfer Ratio Collector-to-Emitter <sup>(2)</sup>	$I_F = 3.0\text{ mA}, V_{CE} = 5.0\text{ V}$	MCT5210M	70			%
		$I_F = 1.6\text{ mA}, V_{CE} = 5.0\text{ V}$	MCT5211M	150			%
		$I_F = 1.0\text{ mA}, V_{CE} = 5.0\text{ V}$		110			%
$CTR_{(CB)}$	Current Transfer Ratio Collector-to-Base <sup>(3)</sup>	$I_F = 3.0\text{ mA}, V_{CE} = 4.3\text{ V}$	MCT5210M	0.2			%
		$I_F = 1.6\text{ mA}, V_{CE} = 4.3\text{ V}$	MCT5211M	0.3			%
		$I_F = 1.0\text{ mA}, V_{CE} = 4.3\text{ V}$		0.25			%
$V_{CE(SAT)}$	Saturation Voltage	$I_F = 3.0\text{ mA}, I_{CE} = 1.8\text{ mA}$	MCT5210M			0.4	V
		$I_F = 1.6\text{ mA}, I_{CE} = 1.6\text{ mA}$	MCT5211M			0.4	V
<b>AC CHARACTERISTICS</b>							
$T_{PHL}$	Propagation Delay HIGH-to-LOW <sup>(4)</sup>	$R_L = 330\ \Omega, R_{BE} = \infty$	$I_F = 3.0\text{ mA}, V_{CC} = 5.0\text{ V}$	MCT5210M	10		$\mu\text{s}$
		$R_L = 3.3\text{ k}\Omega, R_{BE} = 39\text{ k}\Omega$			7		$\mu\text{s}$
		$R_L = 750\ \Omega, R_{BE} = \infty$	$I_F = 1.6\text{ mA}, V_{CC} = 5.0\text{ V}$	MCT5211M	14		$\mu\text{s}$
		$R_L = 4.7\text{ k}\Omega, R_{BE} = 91\text{ k}\Omega$			15		$\mu\text{s}$
		$R_L = 1.5\text{ k}\Omega, R_{BE} = \infty$	$I_F = 1.0\text{ mA}, V_{CC} = 5.0\text{ V}$	MCT5211M	17		$\mu\text{s}$
		$R_L = 10\text{ k}\Omega, R_{BE} = 160\text{ k}\Omega$			24		$\mu\text{s}$
$T_{PLH}$	Propagation Delay LOW-to-HIGH <sup>(5)</sup>	$R_L = 330\ \Omega, R_{BE} = \infty$	$I_F = 3.0\text{ mA}, V_{CC} = 5.0\text{ V}$	MCT5210M	0.4		$\mu\text{s}$
		$R_L = 3.3\text{ k}\Omega, R_{BE} = 39\text{ k}\Omega$			8		$\mu\text{s}$
		$R_L = 750\ \Omega, R_{BE} = \infty$	$I_F = 1.6\text{ mA}, V_{CC} = 5.0\text{ V}$	MCT5211M	2.5		$\mu\text{s}$
		$R_L = 4.7\text{ k}\Omega, R_{BE} = 91\text{ k}\Omega$			11		$\mu\text{s}$
		$R_L = 1.5\text{ k}\Omega, R_{BE} = \infty$	$I_F = 1.0\text{ mA}, V_{CC} = 5.0\text{ V}$	MCT5211M	7		$\mu\text{s}$
		$R_L = 10\text{ k}\Omega, R_{BE} = 160\text{ k}\Omega$			16		$\mu\text{s}$

**Notes:**

- DC Current Transfer Ratio ( $CTR_{CE}$ ) is defined as the transistor collector current ( $I_{CE}$ ) divided by the input LED current ( $I_F$ )  $\times 100\%$ , at a specified voltage between the collector and emitter ( $V_{CE}$ ).
- The collector base Current Transfer Ratio ( $CTR_{CB}$ ) is defined as the transistor collector base photocurrent ( $I_{CB}$ ) divided by the input LED current ( $I_F$ )  $\times 100\%$ .
- Referring to Figure 16 the  $T_{PHL}$  propagation delay is measured from the 50% point of the rising edge of the data input pulse to the 1.3 V point on the falling edge of the output pulse.
- Referring to Figure 16 the  $T_{PLH}$  propagation delay is measured from the 50% point of the falling edge of data input pulse to the 1.3 V point on the rising edge of the output pulse.

**Electrical Characteristics** (Continued) $T_A = 25^\circ\text{C}$  unless otherwise specified.**Isolation Characteristics**

Symbol	Characteristic	Test Conditions	Min.	Typ.	Max.	Unit
$V_{\text{ISO}}$	Input-Output Isolation Voltage <sup>(6)</sup>	$t = 1$ Minute	4170			$V_{\text{AC}_{\text{RMS}}}$
$R_{\text{ISO}}$	Isolation Resistance <sup>(6)</sup>	$V_{\text{I-O}} = \pm 500$ VDC, $T_A = 25^\circ\text{C}$	$10^{11}$			$\Omega$
$C_{\text{ISO}}$	Isolation Capacitance <sup>(7)</sup>	$V_{\text{I-O}} = 0$ V, $f = 1$ MHz		0.4	0.6	pF
$CM_{\text{H}}$	Common Mode Transient Rejection – Output HIGH	$V_{\text{CM}} = 50$ V <sub>P-P</sub> , $R_{\text{L}} = 750$ $\Omega$ , $I_{\text{F}} = 0$		5000		V/ $\mu\text{s}$
$CM_{\text{L}}$	Common Mode Transient Rejection – Output LOW	$V_{\text{CM}} = 50$ V <sub>P-P</sub> , $R_{\text{L}} = 750$ $\Omega$ , $I_{\text{F}} = 1.6$ mA		5000		V/ $\mu\text{s}$

**Notes:**

- Device considered a two terminal device: pins 1, 2, and 3 shorted together and pins 5, 6 and 7 are shorted together.
- $C_{\text{ISO}}$  is the capacitance between the input (pins 1, 2, 3 connected) and the output (pin 4, 5, 6 connected).

### Typical Performance Curves

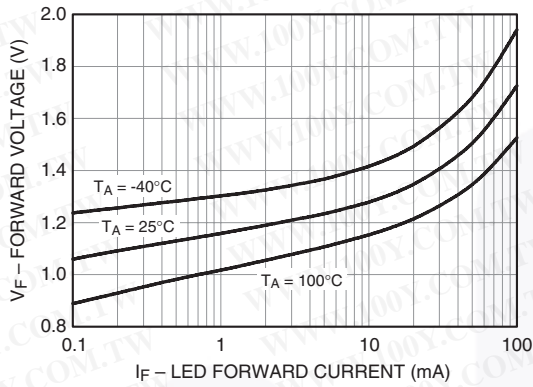

**Figure 3. LED Forward Voltage vs. Forward Current**

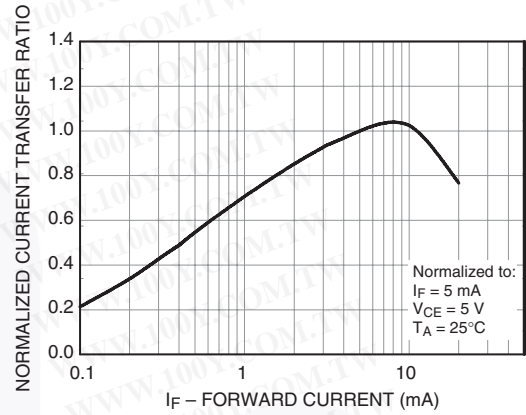

**Figure 4. Normalized Current Transfer Ratio vs. Forward Current**

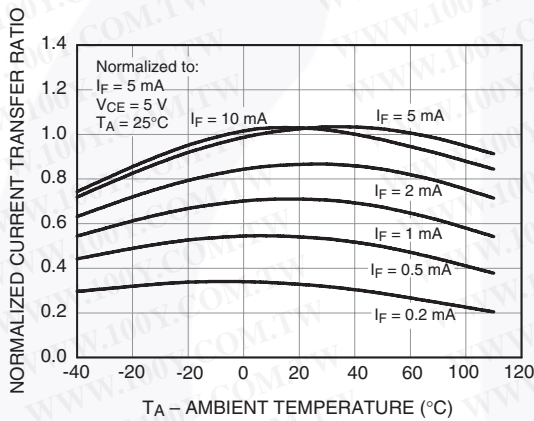

**Figure 5. Normalized CTR vs. Temperature**

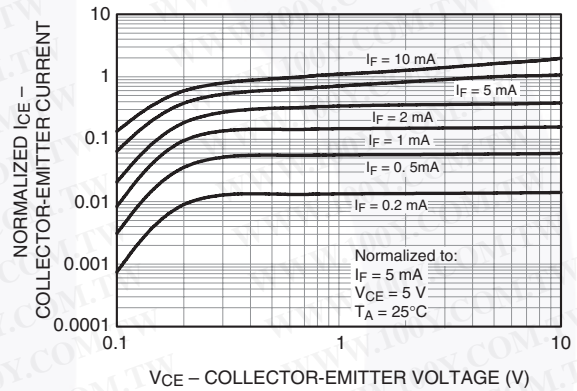

**Figure 6. Normalized Collector vs. Collector-Emitter Voltage**

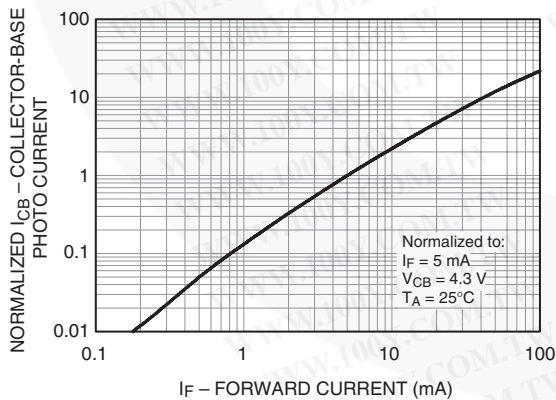

**Figure 7. Normalized Collector Base Photocurrent Ratio vs. Forward Current**

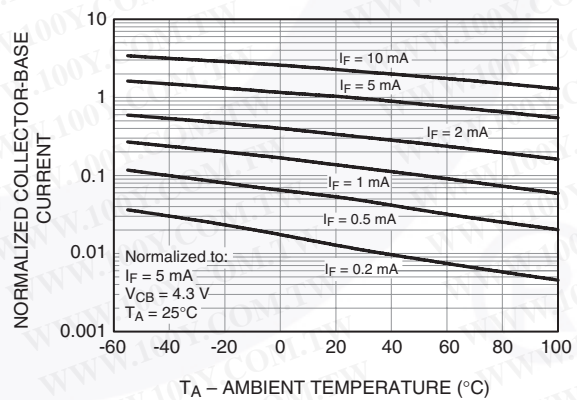

**Figure 8. Normalized Collector-Base Current vs. Temperature**



**Typical Performance Curves (Continued)**

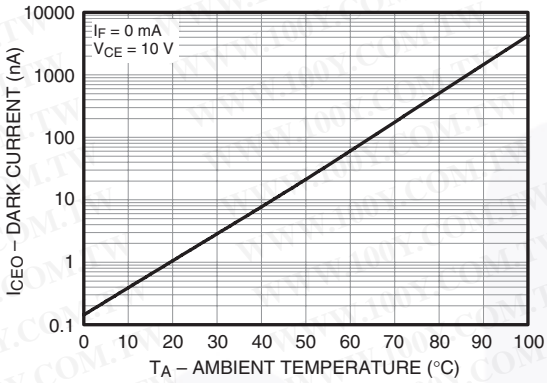

**Figure 9. Collector-Emitter Dark Current vs. Ambient Temperature**

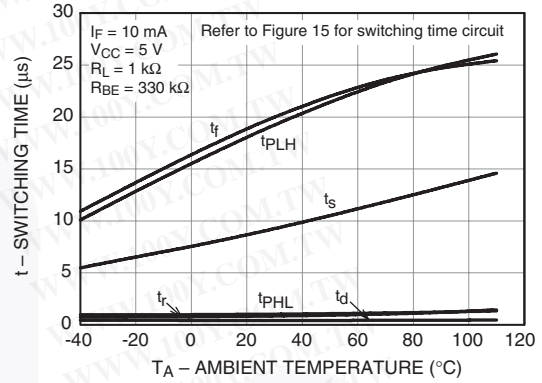

**Figure 10. Switching Time vs. Ambient Temperature**

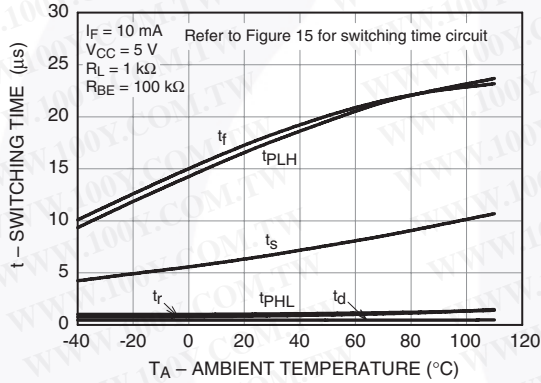

**Figure 11. Switching Time vs. Ambient Temperature**

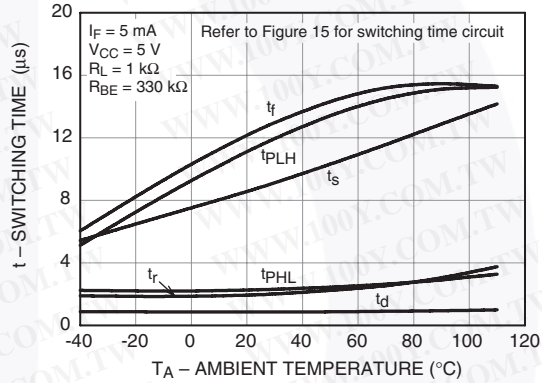

**Figure 12. Switching Time vs. Ambient Temperature**

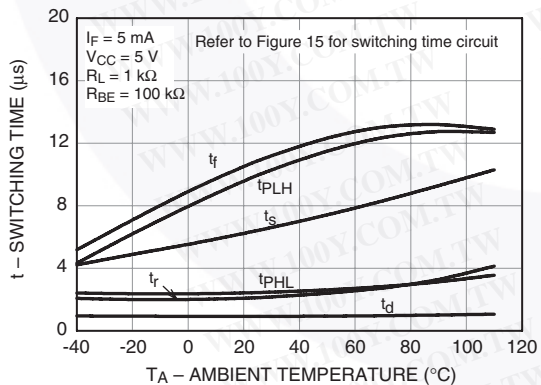

**Figure 13. Switching Time vs. Ambient Temperature**

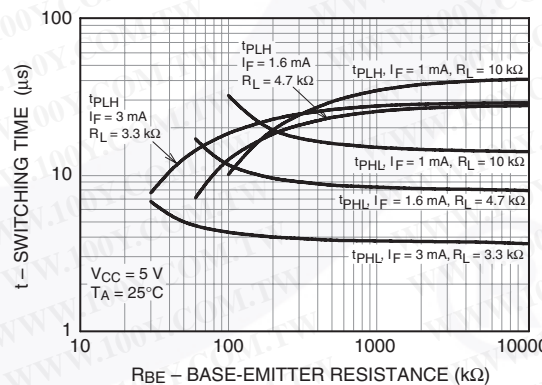

**Figure 14. Switching Time vs. Base-Emitter Resistance**

### Switching Time Test Circuits and Waveforms

$T_A = 25^\circ\text{C}$  unless otherwise specified.

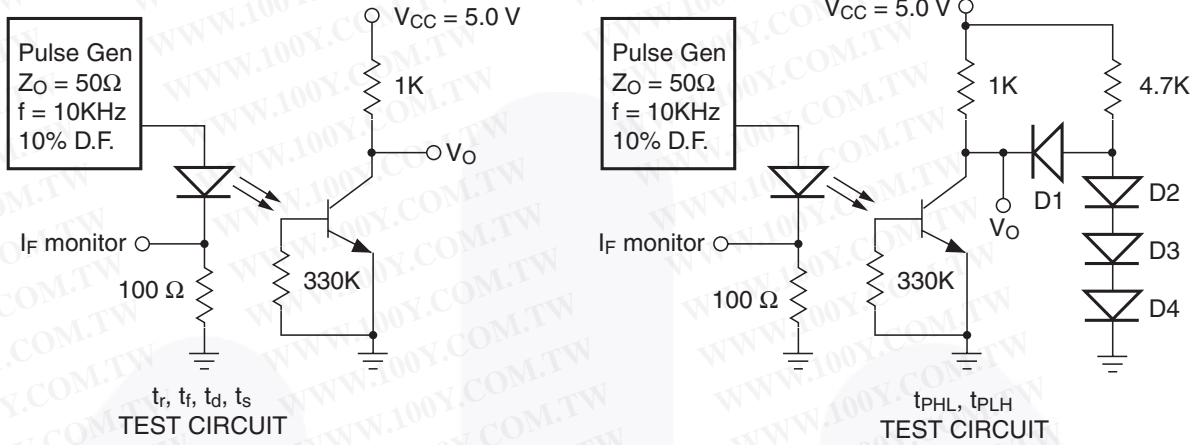

Figure 15. Switching Time Test Circuits

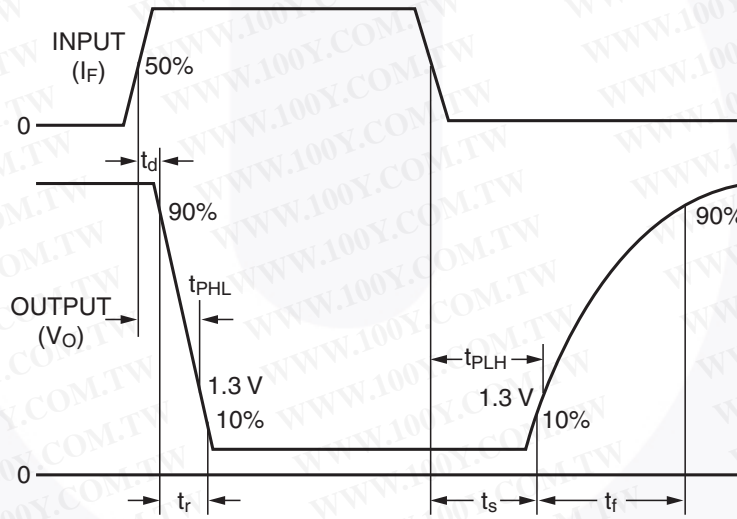

Figure 16. Switching Time Waveforms

### Reflow Profile

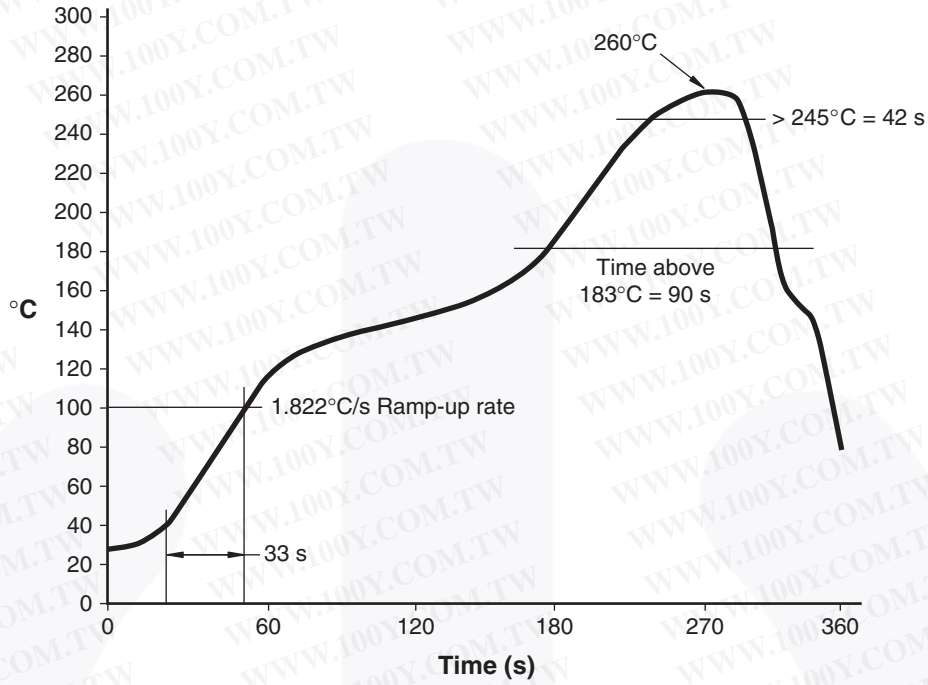

Figure 17. Reflow Profile

## Ordering Information

Part Number	Package	Packing Method
MCT5210M	DIP 6-Pin	Tube (50 Units)
MCT5210SM	SMT 6-Pin (Lead Bend)	Tube (50 Units)
MCT5210SR2M	SMT 6-Pin (Lead Bend)	Tape and Reel (1000 Units)
MCT5210VM	DIP 6-Pin, DIN EN/IEC60747-5-5 Option	Tube (50 Units)
MCT5210SVM	SMT 6-Pin (Lead Bend), DIN EN/IEC60747-5-5 Option	Tube (50 Units)
MCT5210SR2VM	SMT 6-Pin (Lead Bend), DIN EN/IEC60747-5-5 Option	Tape and Reel (1000 Units)
MCT5210TVM	DIP 6-Pin, 0.4" Lead Spacing, DIN EN/IEC60747-5-5 Option	Tube (50 Units)

**Note:**

8. The product orderable part number system listed in this table also applies to the MCT5211M device.

## Marking Information

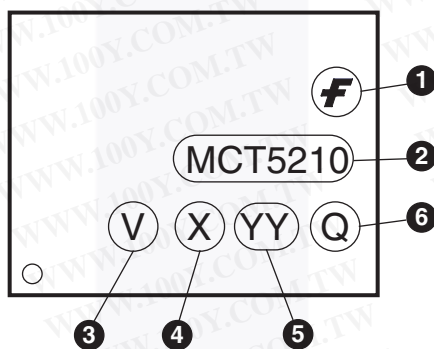
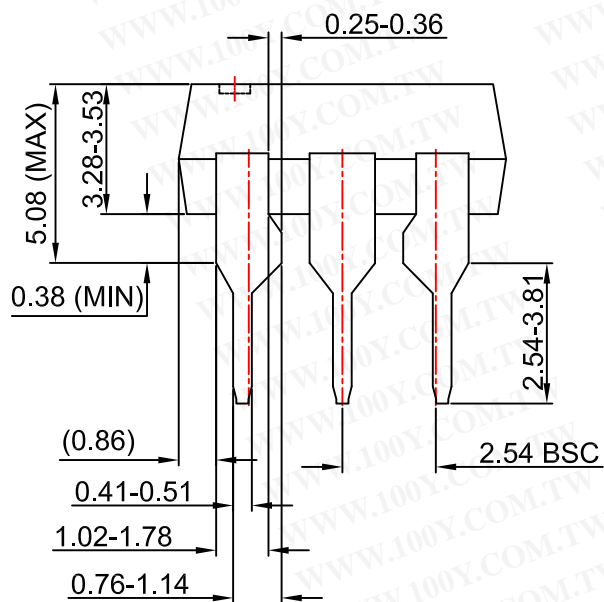
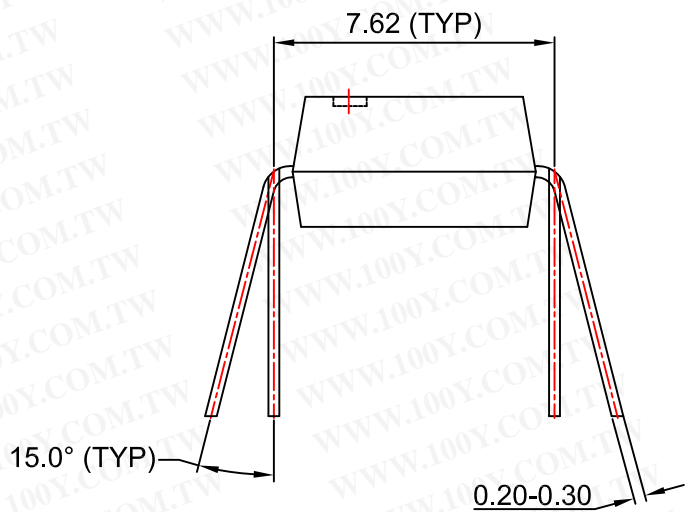
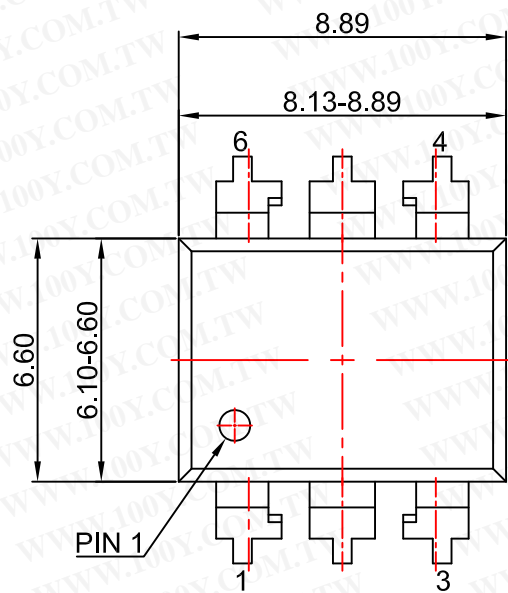

Figure 18. Top Mark

Table 1. Top Mark Definitions

1	Fairchild Logo
2	Device Number
3	DIN EN/IEC60747-5-5 Option (only appears on component ordered with this option)
4	One-Digit Year Code, e.g., "5"
5	Digit Work Week, Ranging from "01" to "53"
6	Assembly Package Code





NOTES:

- A) NO STANDARD APPLIES TO THIS PACKAGE.
- B) ALL DIMENSIONS ARE IN MILLIMETERS.
- C) DIMENSIONS ARE EXCLUSIVE OF BURRS, MOLD FLASH, AND TIE BAR EXTRUSION
- D) DRAWING FILENAME AND REVISION: MKT-N06BREV4.



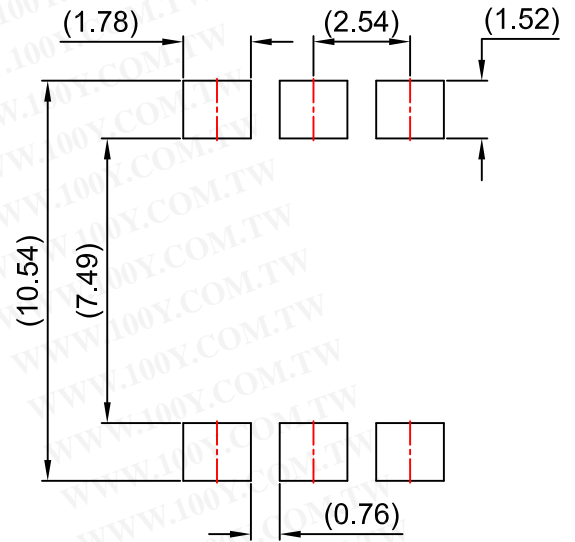
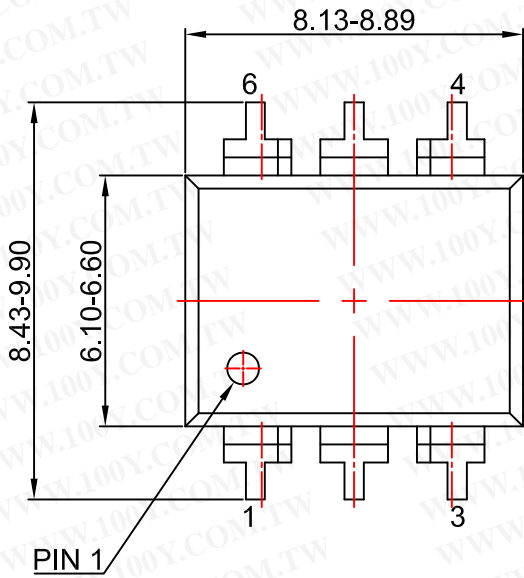

LAND PATTERN RECOMMENDATION

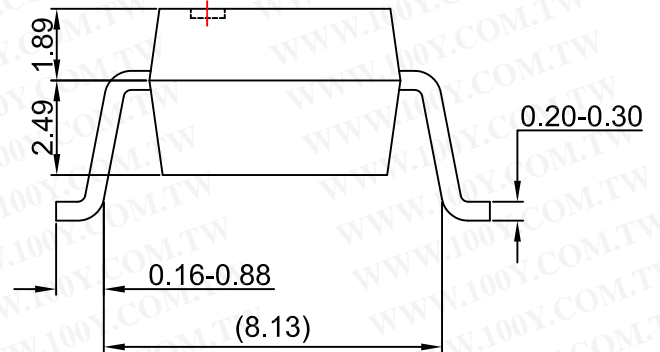
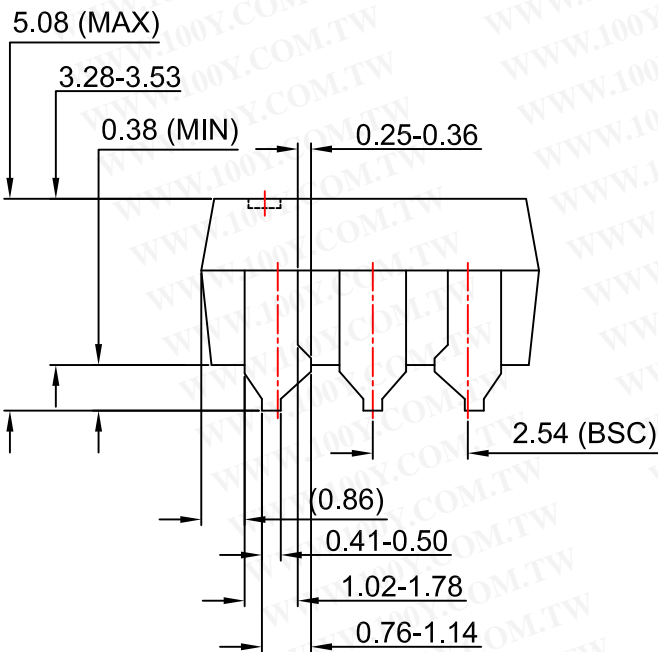

NOTES:

- A) NO STANDARD APPLIES TO THIS PACKAGE.
- B) ALL DIMENSIONS ARE IN MILLIMETERS.
- C) DIMENSIONS ARE EXCLUSIVE OF BURRS, MOLD FLASH, AND TIE BAR EXTRUSION
- D) DRAWING FILENAME AND REVISION : MKT-N06CREV4.



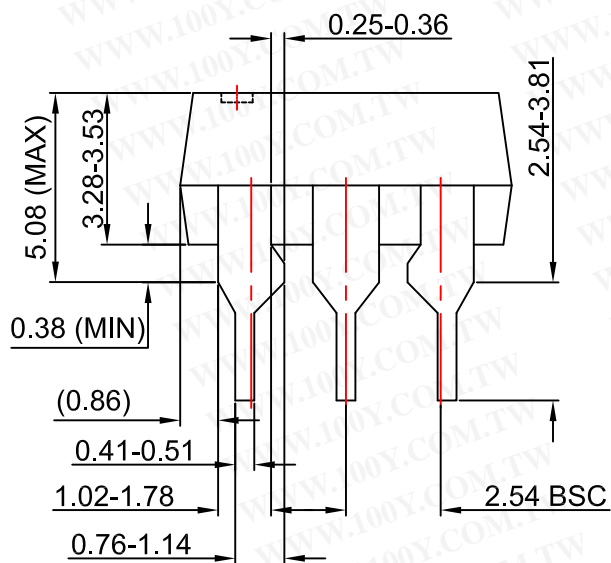
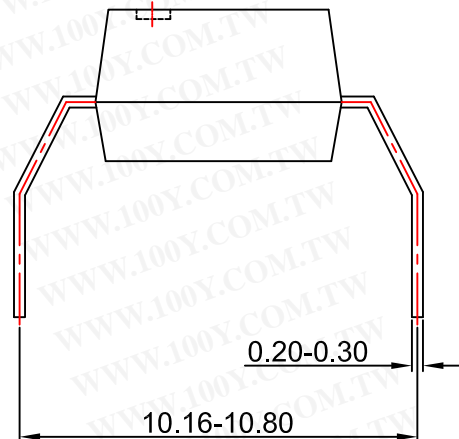
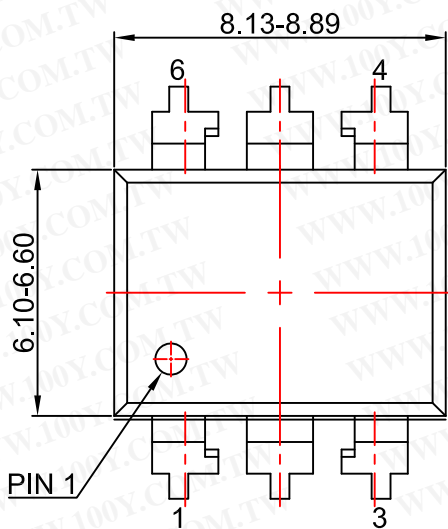

NOTES:

- A) NO STANDARD APPLIES TO THIS PACKAGE.
- B) ALL DIMENSIONS ARE IN MILLIMETERS.
- C) DIMENSIONS ARE EXCLUSIVE OF BURRS, MOLD FLASH, AND TIE BAR EXTRUSION
- D) DRAWING FILENAME AND REVISION: MKT-N06Drev4



勝特力材料 886-3-5753170  
 勝特力电子(上海) 86-21-34970699  
 勝特力电子(深圳) 86-755-83298787  
[Http://www.100y.com.tw](http://www.100y.com.tw)