

Slotted Optical Switch

OPB825, OPB825A, OPB825B



勝特力材料 886-3-5753170
 勝特力电子(上海) 86-21-34970699
 勝特力电子(深圳) 86-755-83298787
[Http://www.100y.com.tw](http://www.100y.com.tw)

Features:

- Non-contact switching
- Fast switching speed
- 0.160" (4.06 mm) wide slot
- 0.300" (7.62 mm) lead spacing

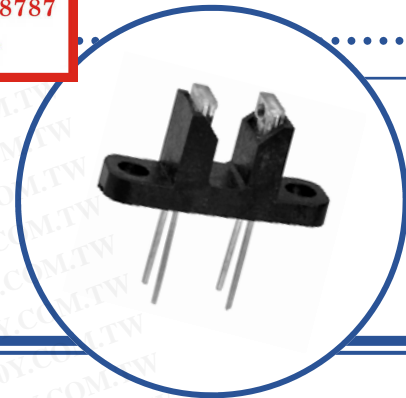

Description:

Each **OPB825**, **OPB825A** and **OPB825B** consists of an infrared emitting diode and a NPN silicon phototransistor mounted in a low-cost black plastic housing on opposite sides of a 0.160" (4.064 mm) wide slot.

OPB825 has no mounting tabs and is intended for direct insertion into PCBoards or dual-in-line sockets. **OPB825A** has one mounting tab on the phototransistor side, while **OPB825B** has mounting tabs on both sides (two tabs).

Phototransistor switching takes place whenever an opaque object passes through the slot.

Custom electrical, wire and cabling and connectors are available. Contact your local representative or OPTEK for more information.

Applications:

- Non-contact interruptive object sensing
- Assembly line automation
- Machine automation
- Equipment security
- Machine safety

Ordering Information	
Part Number	Description
OPB825	Slotted Switch (no tabs)
OPB825A	Slotted Switch (one tab)
OPB825B	Slotted Switch (two tabs)

Pin #	Description	Pin #	Description
1	Anode	3	Collector
2	Cathode	4	Emitter

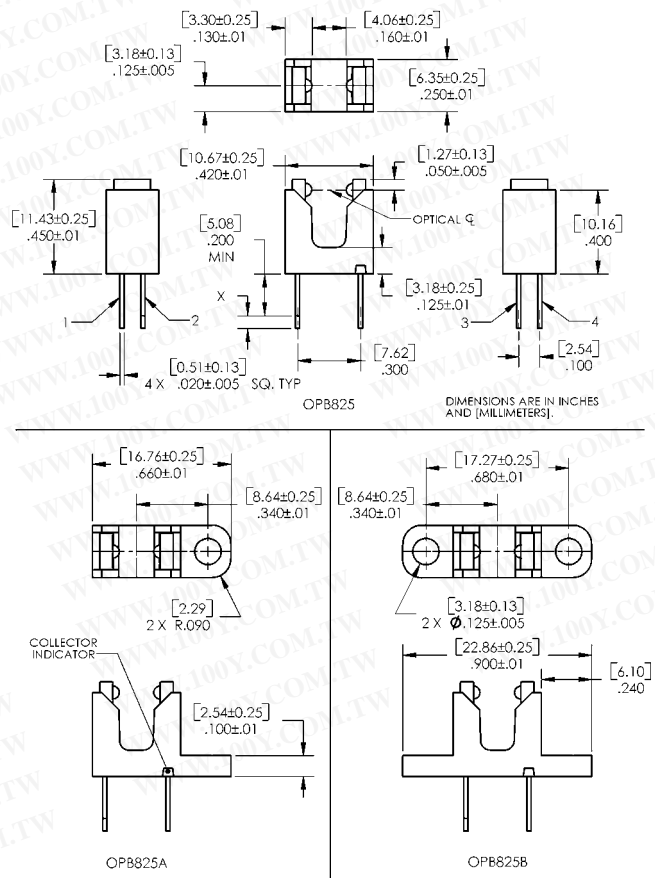
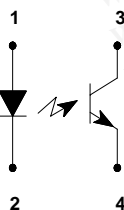

RoHS

OPTEK reserves the right to make changes at any time in order to improve design and to supply the best product possible.

Absolute Maximum Ratings ($T_A=25^{\circ}\text{C}$ unless otherwise noted)

Storage & Operating Temperature Range	-40°C to +85° C
Lead Soldering Temperature [1/16 inch (1.6mm) from the case for 5 sec. with soldering iron] ⁽¹⁾	260° C

Input Diode

Forward DC Current	50 mA
Peak Forward Current (1 μs pulse width, 300 pps)	3 A
Reverse DC Voltage	2 V
Power Dissipation ⁽²⁾	100 mW

Output Phototransistor

Collector-Emitter Voltage	30 V
Emitter-Collector Voltage	5 V
Collector DC Current	30 mA
Power Dissipation ⁽²⁾	100 mW

Electrical Characteristics ($T_A = 25^{\circ}\text{C}$ unless otherwise noted)

SYMBOL	PARAMETER	MIN	TYP	MAX	UNITS	TEST CONDITIONS
--------	-----------	-----	-----	-----	-------	-----------------

Input Diode (See OP240 for additional information)

V_F	Forward Voltage	-	-	1.6	V	$I_F = 20 \text{ mA}$
I_R	Reverse Current	-	-	100	μA	$V_R = 2 \text{ V}$

Output Phototransistor (See OP550 for additional information)

$V_{(BR)CEO}$	Collector-Emitter Breakdown Voltage	30	-	-	V	$I_C = 1 \text{ mA}$
$V_{(BR)ECO}$	Emitter-Collector Breakdown Voltage	5	-	-	V	$I_E = 100 \mu\text{A}$
I_{CEO}	Collector Dark Current	-	-	100	nA	$V_{CE} = 10 \text{ V}, I_F = 0, E_E = 0$

Combined

$V_{CE(SAT)}$	Collector-Emitter Saturation	-	-	0.4	V	$I_C = 250 \mu\text{A}, I_F = 20 \text{ mA}$
$I_{C(ON)}$	On-State Collector Current	1.0	-	45.0	mA	$I_F = 20 \text{ mA}, V_{CE} = 10 \text{ V}$

Notes:

- (1) RMA flux is recommended. Duration can be extended to 10 seconds maximum when flow soldering.
- (2) Derate linearly 1.67 mW/°C above 25 ° C.
- (3) All parameters tested using pulse techniques.
- (4) Methanol or isopropanol are recommended as cleaning agents. Plastic housing is soluble in chlorinated hydrocarbons and ketones.

OPTEK reserves the right to make changes at any time in order to improve design and to supply the best product possible.

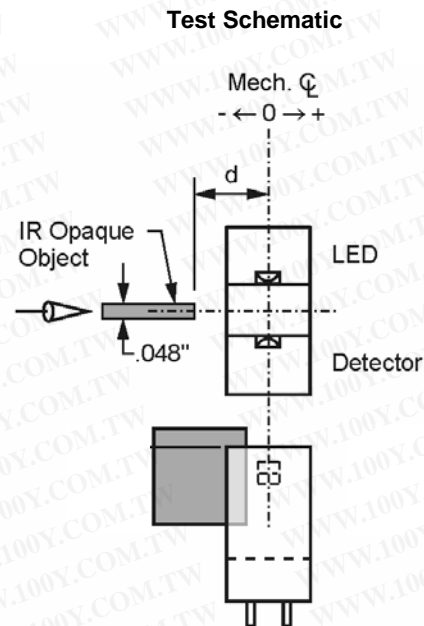
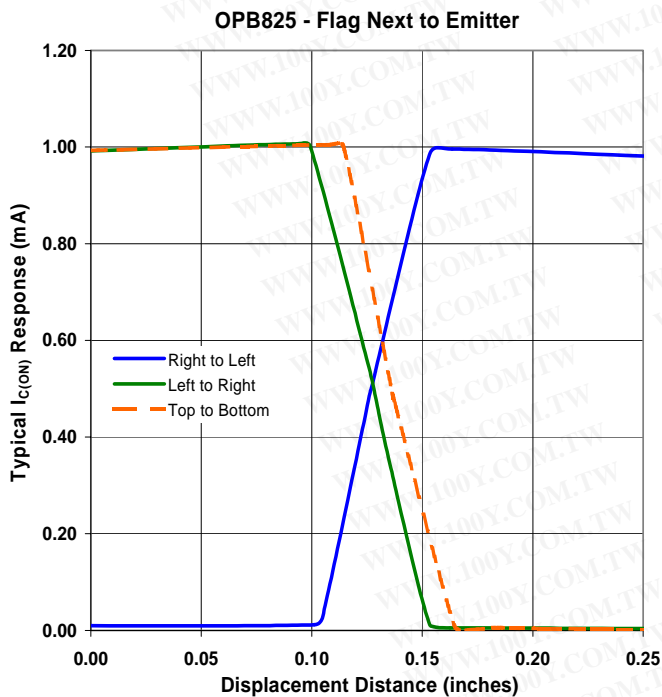
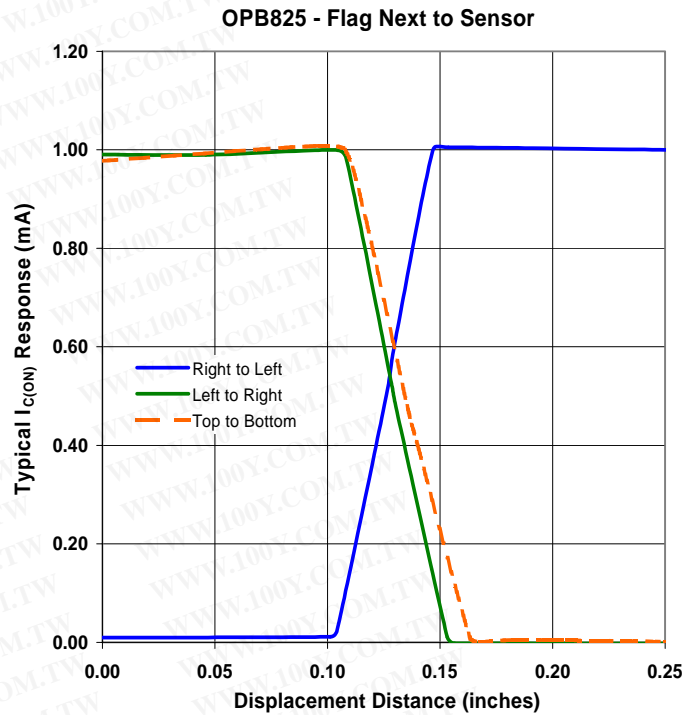
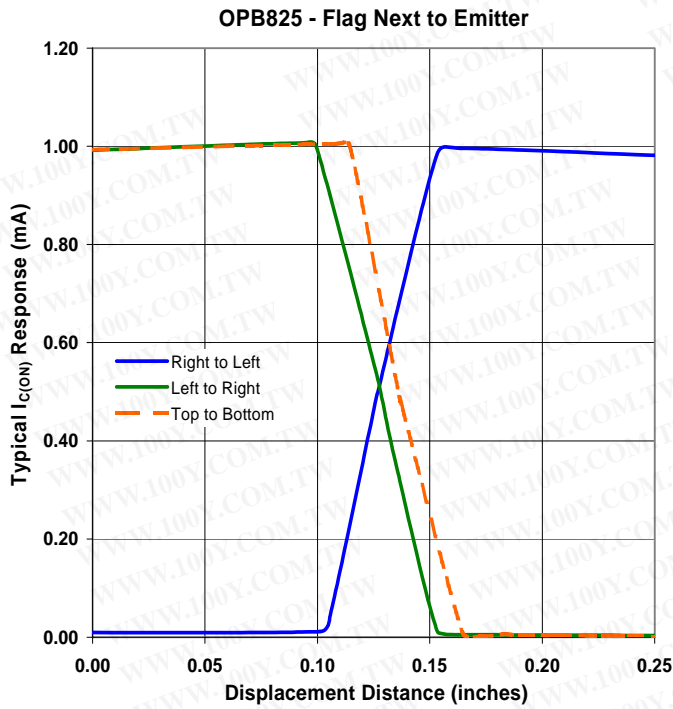

勝特力材料 886-3-5753170
 勝特力电子(上海) 86-21-34970699
 勝特力电子(深圳) 86-755-83298787
[Http://www.100y.com.tw](http://www.100y.com.tw)

OPTEK reserves the right to make changes at any time in order to improve design and to supply the best product possible.