

### ◆ Characteristic :

- High-speed response : 2kHz.
- Sensing distance 6mm, suitable for the detection of small objects.
- Infrared beam axis 0.8x2mm width.



### ◆ Specifications :

Model	RX670-N	RX671-N	RX672-N	RX673-N
	RX670-P	RX671-P	RX672-P	RX673-P
Sensing distance	6 mm			
Output type	NPN L.on/D.on PNP L.on/D.on	NPN L.on/D.on PNP L.on/D.on	NPN L.on/D.on PNP L.on/D.on	NPN L.on/D.on PNP L.on/D.on
Emitting light	Infrared LED 940 nm			
Operating voltage	DC10 ~ 30 V			
Current Consumption	15 mA Max.			
Load current	100mA Max. at DC24V			
Response time	0.5 ms Max.			
Insulation resistance	20MΩ min. (DC500V)			
Voltage withstandability	AC1000V 60Hz for 60 Sec.			
Operating temperature	0 °C ~ +60 °C			
Ambient humidity	35% ~ 85% RH			
Material	ABS			
Protection degree	IP50			
Option (Page 256)	EE-1001 / RE-1006-PVC-2M			
Weight	Approx.3.5g	Approx.3.5g	Approx. 3g	Approx. 3g

勝特力材料 886-3-5753170  
 勝特力电子(上海) 86-21-34970699  
 勝特力电子(深圳) 86-755-83298787  
[Http://www.100y.com.tw](http://www.100y.com.tw)

### ◆ Dimensions : (unit:mm)

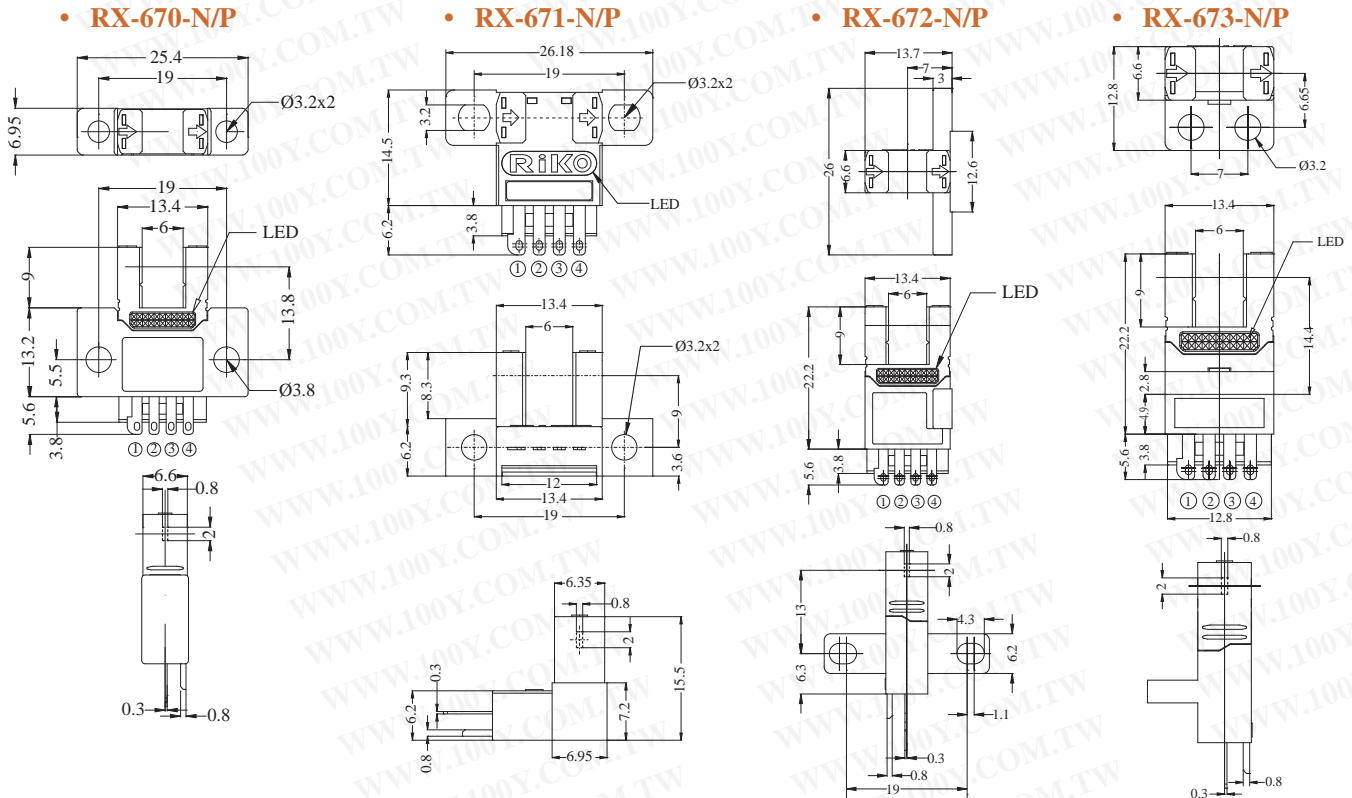

### ◆ Wiring diagrams :

Pin fitting			
①	②	③	④
+	L	OUT	-

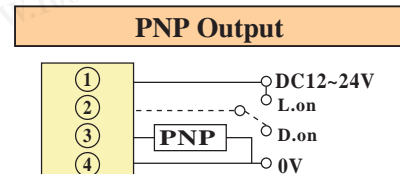
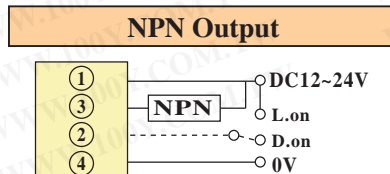

Photo / Area Photo / Ultrasonic Sensor

R5JM /R3JK

PTQ18

PMF /RMF /MMF

PK3 /PK5 /PM6

SU /SU15 /SU07 /SU30

SPR /RX

OAP /ASP

RU18

# U-shape Photo Sensor

# RX

## ◆ Characteristic / 特點 :

- High-speed response : 2kHz.  
/ 體積小, 反應速度快約2kHz。
- Sensing distance 6mm, suitable for the detection of small objects.  
/ 檢測距離6mm, 適用於小物體檢測。
- Infrared beam axis 0.8x2mm width.  
/ 紅外線光軸檢測寬度0.8x2mm。



## ◆ Specifications / 規格表 :

Model / 型號	RX674-N	RX675-N	RX676-N	RX677-N
	RX674-P	RX675-P	RX676-P	RX677-P
Sensing distance / 檢出距離	6 mm			
Output type / 輸出模式	NPN L.on/D.on	NPN L.on/D.on	NPN L.on/D.on	NPN L.on/D.on
	PNP L.on/D.on	PNP L.on/D.on	PNP L.on/D.on	PNP L.on/D.on
Emitting light / 發光源	Infrared LED 940 nm			
Operating voltage / 工作電壓	DC10 ~ 30 V			
Current Consumption / 消耗電流	15 mA Max.			
Load current / 負載電流	100mA Max. at DC24V			
Response time / 反應時間	0.5 ms Max.			
Insulation resistance / 隔離阻抗	20MΩ min. (DC500V)			
Voltage withstandability / 絕緣耐壓	AC1000V 60Hz for 60 Sec.			
Operating temperature/工作溫度	0 °C ~ +60 °C			
Ambient humidity / 工作溼度	35% ~ 85% RH			
Material / 外觀材質	ABS			
Protection degree / 防水等級	IP50			
Option / 選購配件 (Page 256)	EE-1001 / RE-1006-PVC-2M			
Weight / 重量	Approx.3.5g	Approx.3g	Approx. 3g	Approx. 3 g

勝特力材料 886-3-5753170  
 勝特力电子(上海) 86-21-34970699  
 勝特力电子(深圳) 86-755-83298787  
[Http://www.100y.com.tw](http://www.100y.com.tw)

## ◆ Dimensions / 尺寸圖 : (unit:mm)

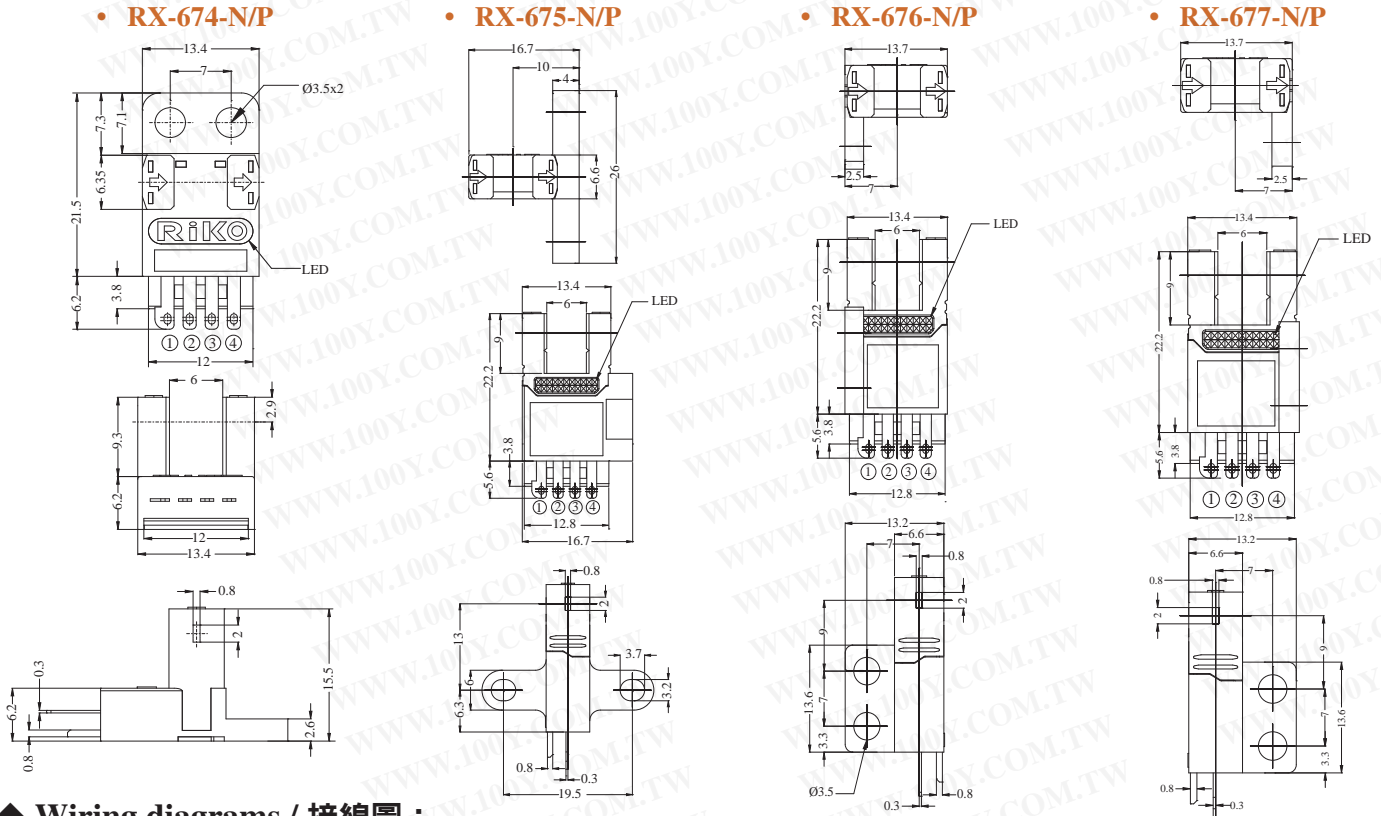

## ◆ Wiring diagrams / 接線圖 :

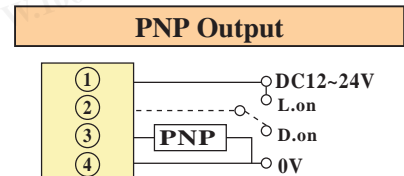
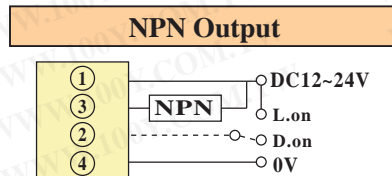
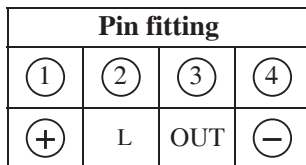

Photo / Area Photo / Ultrasonic Sensor

R5JM /R3JK

PTQ18

PMF /RMF /MMF

PK3 /PK5 /PM6

SU /SU15 /SU07 /SU30

SPR /RX

OAP /ASP

RU18