

## LED Specification

EC/Opto Group

勝特力材料 886-3-5753170  
勝特力电子(上海) 86-21-34970699  
勝特力电子(深圳) 86-755-83298787  
[Http://www.100y.com.tw](http://www.100y.com.tw)

## PC817XxNiP0F Series Photocoupler

## Product Specification

June 2008

PC817XxNiP0F Series

Full Specification for part numbers:

PC817XNNIP0F

PC817XINIP0F

PC817X2NIP0F

PC817X3NIP0F

PC817X4NIP0F

PC817X5NIP0F

PC817X6NIP0F

PC817X7NIP0F

PC817X8NIP0F

PC817X9NIP0F

PC817XONIP0F



# SHARP

OPTO-ANALOG DEVICES DIVISION  
ELECTRONIC COMPONENTS AND DEVICES GROUP  
SHARP CORPORATION

## SPECIFICATION

DEVICE SPECIFICATION FOR  
PHOTOCOUPLER  
MODEL No. PC817

Business dealing name

	PC817XNNIPOF
	PC817X1NIP0F
	PC817X2NIP0F
	PC817X3NIP0F
	PC817X4NIP0F
	PC817X5NIP0F
	PC817X6NIP0F
	PC817X7NIP0F
	PC817X8NIP0F
	PC817X9NIP0F
	PC817X0NIP0F

Specified for \_\_\_\_\_

Enclosed please find copies of the Specifications which consists of 12 pages including cover.

This specification sheets and attached sheets shall be both side copy.

After confirmation of the contents, please be sure to send back  copies of the Specifications with approving signature on each.

CUSTOMER'S APPROVAL

DATE \_\_\_\_\_

BY \_\_\_\_\_

PRESENTED

DATE June 19, 2008

BY M. Kubo

M. Kubo,  
Department General Manager of  
Engineering Dept., II  
Opto-Analog Devices Div.  
Electronic Components and Devices Group  
SHARP CORPORATION

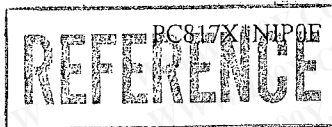

Product name : PHOTOCOUPLER

Model No. : PC817

Business dealing name

PC817XNIP0F
PC817X1NIP0F
PC817X2NIP0F
PC817X3NIP0F
PC817X4NIP0F
PC817X5NIP0F
PC817X6NIP0F
PC817X7NIP0F
PC817X8NIP0F
PC817X9NIP0F
PC817X0NIP0F

1. These specification sheets include materials protected under copyright of Sharp Corporation ("Sharp"). Please do not reproduce or cause anyone to reproduce them without Sharp's consent.
2. When using this product, please observe the absolute maximum ratings and the instructions for use outlined in these specification sheets, as well as the precautions mentioned below. Sharp assumes no responsibility for any damage resulting from use of the product which does not comply with the absolute maximum ratings and the instructions included in these specification sheets, and the precautions mentioned below.

(Precautions)

- (1) This product is designed for use in the following application areas ;

( · OA equipment    Audio visual equipment    · Home appliances  
· Telecommunication equipment (Terminal)    · Measuring equipment  
· Tooling machines    · Computers )

If the use of the product in the above application areas is for equipment listed in paragraphs (2) or (3), please be sure to observe the precautions given in those respective paragraphs.

- (2) Appropriate measures, such as fail-safe design and redundant design considering the safety design of the overall system and equipment, should be taken to ensure reliability and safety when this product is used for equipment which demands high reliability and safety in function and precision, such as ;

( · Transportation control and safety equipment (aircraft, train, automobile etc.)  
· Traffic signals    · Gas leakage sensor breakers    · Rescue and security equipment  
· Other safety equipment )

- (3) Please do not use this product for equipment which require extremely high reliability and safety in function and precision, such as ;

( · Space equipment    · Telecommunication equipment (for trunk lines)  
· Nuclear power control equipment    · Medical equipment )

- (4) Please contact and consult with a Sharp sales representative if there are any questions regarding interpretation of the above three paragraphs.

3. Please contact and consult with a Sharp sales representative for any questions about this product.



1. Application

This specification applies to the outline and characteristics of photocoupler Model No. PC817series(Lead-Free Type).

2. Outline Refer to the attached sheet, page 4.

3. Ratings and characteristics Refer to the attached sheet, page 5, 6.

4. Reliability Refer to the attached sheet, page 7.

5. Outgoing inspection Refer to the attached sheet, page 8.

6. Supplement

6.1 Isolation voltage shall be measured in the following method.

(1) Short between anode and cathode on the primary side and between collector and emitter on the secondary side.

(2) The dielectric withstanding tester with zero-cross circuit shall be used.

(3) The wave form of applied voltage shall be a sine wave.

(It is recommended that the isolation voltage be measured in insulation oil.)

6.2 Package specifications Refer to the attached sheet, page 9, 10.

6.3 Business dealing name ("O" mark indicates business dealing name of ordered product)

Ordered product	Business dealing name	Rank mark	Ic (mA)
	PC817XNNIP0F	with or without	2.5 to 30
	PC817X1NIP0F	A	4.0 to 8.0
	PC817X2NIP0F	B	6.5 to 13
	PC817X3NIP0F	C	10 to 20
	PC817X4NIP0F	D	15 to 30
	PC817X5NIP0F	A or B	4.0 to 13
	PC817X6NIP0F	B or C	6.5 to 20
	PC817X7NIP0F	C or D	10 to 30
	PC817X8NIP0F	A, B or C	4.0 to 20
	PC817X9NIP0F	B, C or D	6.5 to 30
	PC817X0NIP0F	A, B, C or D	4.0 to 30

Test conditions
I <sub>F</sub> =5mA V <sub>CE</sub> =5V T <sub>a</sub> =25°C

6.4 This Model is approved by UL.

Approved Model No. : PC817

UL file No. : E64380

6.5 This product is not designed against irradiation.

This product is assembled with electrical input and output.

This product incorporates non-coherent light emitting diode.

# REFERENCE

## 6.6 ODS materials

This product shall not contain the following materials.

Also, the following materials shall not be used in the production process for this product.

Materials for ODS : CFCs, Halon, Carbon tetrachloride, 1,1,1-Trichloroethane (Methyl chloroform)

## 6.7 Specified brominated flame retardants

Specified brominated flame retardants (PBB and PBDE) are not used in this device at all

## 6.8 Compliance with each regulation

### (1) The RoHS directive (2002/95/EC)

This product complies with the RoHS directive (2002/95/EC).

Object substances: mercury, lead, cadmium, hexavalent chromium, polybrominated biphenyls (PBB) and polybrominated diphenyl ethers (PBDE)

### (2) Content of six substances specified in Management Methods for Control of Pollution Caused by Electronic Information Products Regulation (Chinese : 电子信息产品污染控制管理办法).

Category	Toxic and hazardous substances					
	Lead (Pb)	Mercury (Hg)	Cadmium (Cd)	Hexavalent chromium (Cr <sup>6+</sup> )	Polybrominated biphenyls (PBB)	Polybrominated diphenyl ethers (PBDE)
Photocopier	✓	✓	✓	✓	✓	✓

✓ : indicates that the content of the toxic and hazardous substance in all the homogeneous materials of the part is below the concentration limit requirement as described in SJ/T 11363-2006 standard .

## 7. Notes

Precautions for photocopiers : Attachment-1

# PC817X\*NIP0F REFERENCE

## 2. Outline

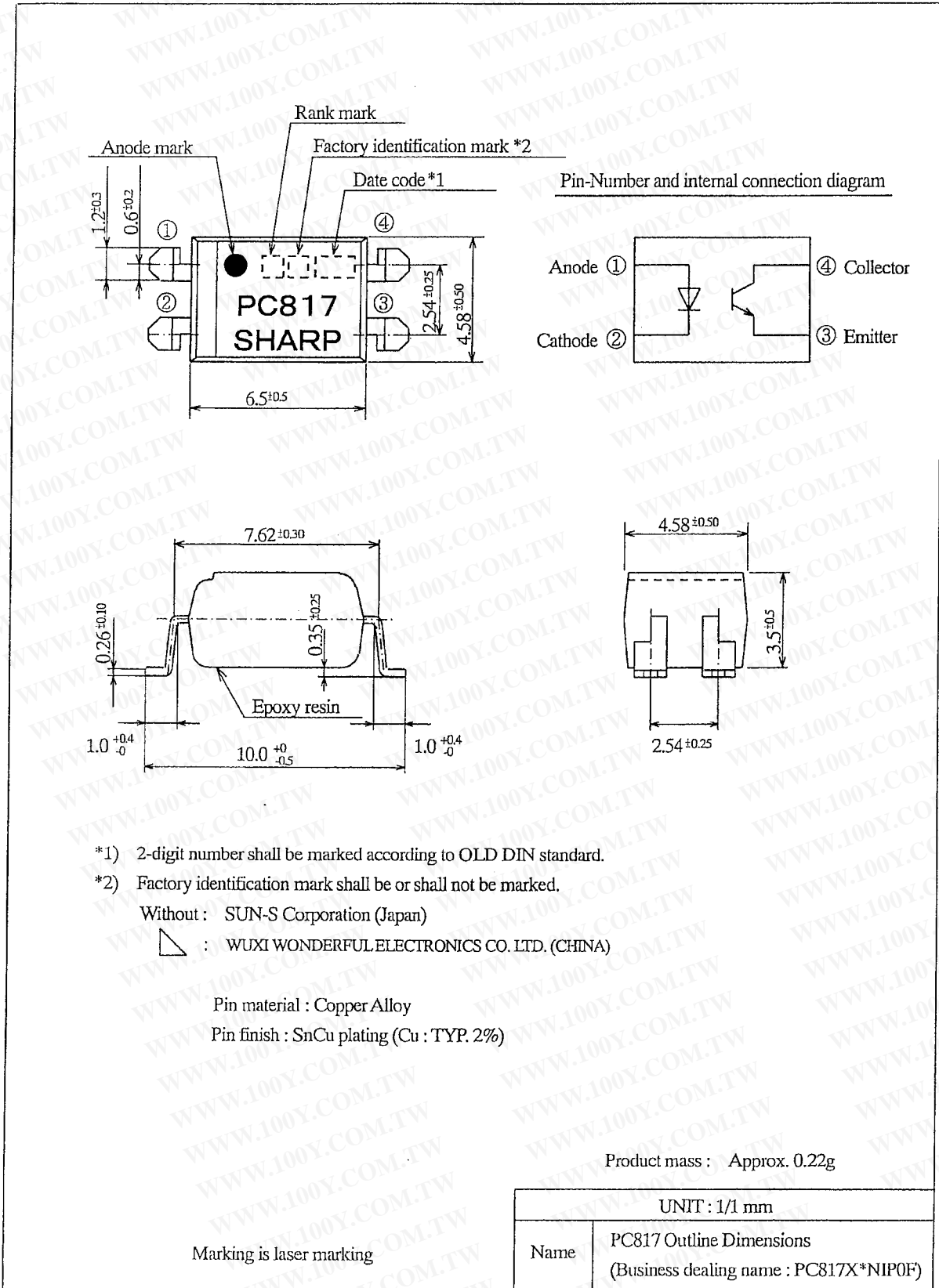

### 3. Ratings and characteristics

#### 3.1 Absolute maximum ratings

Ta=25°C

Parameter		Symbol	Rating	Unit
Input	*1 Forward current	$I_F$	50	mA
	*2 Peak forward current	$I_{FM}$	1	A
	Reverse voltage	$V_R$	6	V
	*1 Power dissipation	P	70	mW
Output	Collector-emitter voltage	$V_{CEO}$	80	V
	Emitter-collector voltage	$V_{ECO}$	6	V
	Collector current	$I_c$	50	mA
	*1 Collector power dissipation	$P_c$	150	mW
*1 Total power dissipation	$P_{tot}$	200	mW	
Operating temperature		$T_{opr}$	-30 to +100	°C
Storage temperature		$T_{slg}$	-55 to +125	°C
*3 Isolation voltage	$V_{iso(rms)}$	5	kV	
*4 Soldering temperature	$T_{sol}$	270	°C	

\*1 The derating factors of absolute maximum ratings due to ambient temperature are shown in Fig. 1 to 4.

\*2 Pulse width  $\leq 100\mu s$ , Duty ratio : 0.001 (Refer to Fig. 5)

\*3 AC for 1 min, 40 to 60%RH

\*4 For 10 s

#### 3.2 Electro-optical characteristics

Ta=25°C

Parameter		Symbol	Condition	MIN.	TYP.	MAX.	Unit
Input	Forward voltage	$V_F$	$I_F=20mA$	-	1.2	1.4	V
	Peak forward voltage	$V_{FM}$	$I_{FM}=0.5A$	-	-	3.0	V
	Reverse current	$I_R$	$V_R=4V$	-	-	10	$\mu A$
	Terminal capacitance	$C_t$	$V=0, f=1kHz$	-	30	250	pF
Output	Dark current	$I_{CEO}$	$V_{CE}=50V, I_F=0$	-	-	100	nA
	Collector-emitter breakdown voltage	$BV_{CEO}$	$I_c=0.1mA, I_F=0$	80	-	-	V
	Emitter-collector breakdown voltage	$BV_{ECO}$	$I_E=10\mu A, I_F=0$	6	-	-	V
Transfer characteristics	Collector current	$I_c$	$I_F=5mA, V_{CE}=5V$	2.5	-	30	mA
	Collector-emitter saturation voltage	$V_{CE(sat)}$	$I_F=20mA, I_c=1mA$	-	0.1	0.2	V
	Isolation resistance	$R_{ISO}$	DC500V 40 to 60%RH	$5 \times 10^{10}$	$10^{11}$	-	$\Omega$
	Floating capacitance	$C_f$	$V=0, f=1MHz$	-	0.6	1.0	pF
	Cut-off frequency	$f_c$	$V_{CE}=5V, I_c=2mA$ $R_L=100\Omega, -3dB$	-	80	-	kHz
	Rise time	$t_r$	$V_{CE}=2V, I_c=2mA$	-	4	18	$\mu s$
	Fall time	$t_f$	$R_L=100\Omega$	-	3	18	$\mu s$

(Fig. 1) Forward current vs. ambient temperature

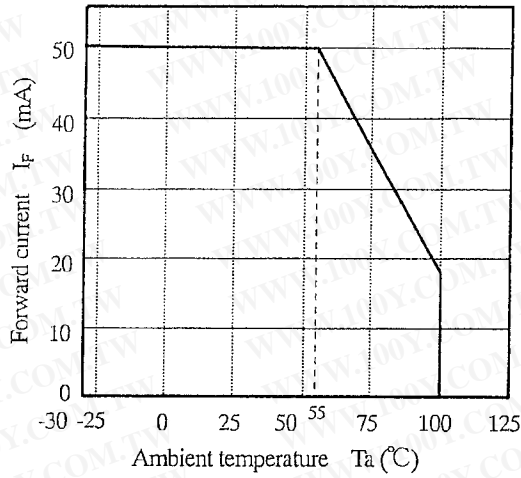

(Fig. 2) Diode power dissipation vs. ambient temperature

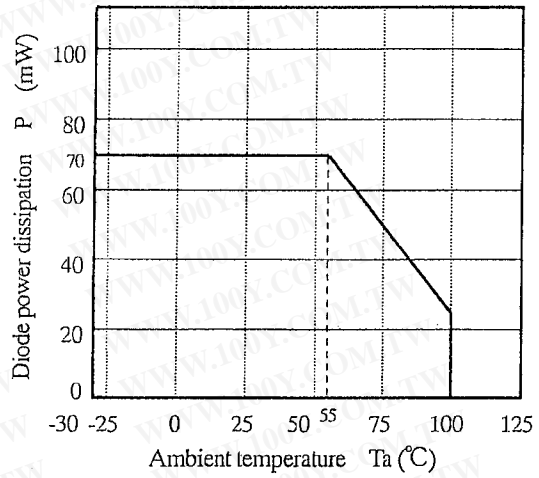

(Fig. 3) Collector power dissipation vs. ambient temperature

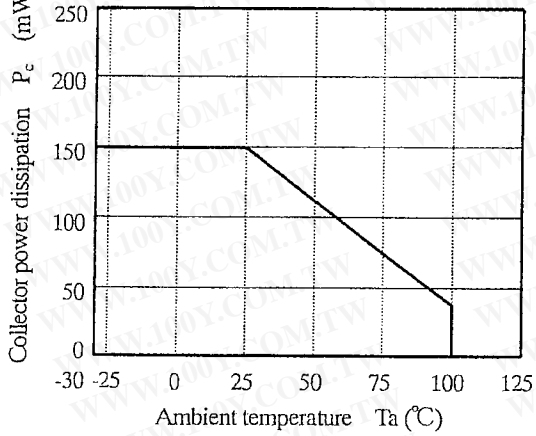

(Fig. 4) Total power dissipation vs. ambient temperature

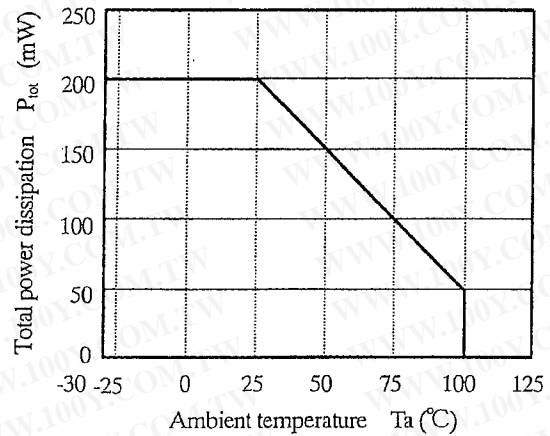

(Fig. 5) Peak forward current vs. duty ratio  
Pulse width  $\leq 100 \mu s$   
 $T_a = 25^\circ C$

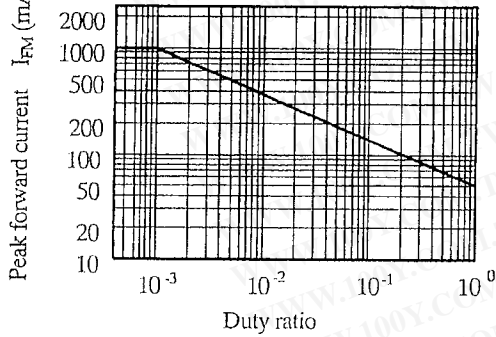



# REFERENCE

## 4. Reliability

The reliability of products shall satisfy items listed below.

Confidence level : 90%  
LTPD : 10 or 20

Test Items	Condition #1	Failure Judgment Criteria	Samples (n) Defective (C)
Solderability	245±3°C, 5s	*2	n=11, C=0
Soldering heat	(Flow soldering) 270°C, 10 s	$V_F > U \times 1.2$ $I_R > U \times 2$ $I_{CEO} > U \times 2$ $I_C < L \times 0.7$ $V_{CE(sat)} > U \times 1.2$  U: Upper specification limit  L: Lower specification limit	n=11, C=0
	(Soldering by hand) 400°C, 3 s		n=11, C=0
Terminal strength (Tension)	Weight: 5N 5 s/each terminal		n=11, C=0
Terminal strength Bending) *3	Weight: 2.5N 2 times/each terminal		n=11, C=0
Mechanical shock	15km/s <sup>2</sup> , 0.5ms 3 times/±X, ±Y, ±Z direction		n=11, C=0
Variable frequency vibration	100 to 2000 to 100Hz/4 min 200m/s <sup>2</sup> 4 times/X, Y, Z direction		n=11, C=0
Temperature cycling	1 cycle -55°C to +125°C (30 min) (30 min) 20 cycles test		n=22, C=0
High temp. and high Humidity storage	+85°C, 85%RH, 1000h		n=22, C=0
High temp. storage	+125°C, 1000h		n=22, C=0
Low temp. storage	-55°C, 1000h		n=22, C=0
Operation life	I <sub>F</sub> =50mA, P <sub>tot</sub> =200mW T <sub>a</sub> =25°C, 1000h	n=22, C=0	

\*1 Test method, conforms to BIAJ ED 4701.

\*2 The product whose not-soldered area is more than 5% for all of the dipped area and/or whose pinholes or voids are concentrated on one place shall be judged defect.

\*3 Terminal bending direction is shown below.

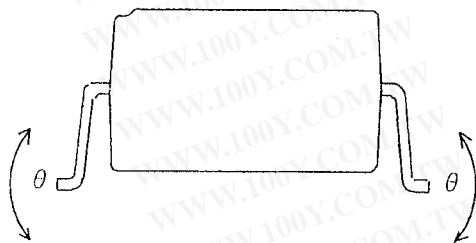

# REFERENCE

## 5. Outgoing inspection

### 5.1 Inspection items

#### (1) Electrical characteristics

$V_{F}$ ,  $I_{R}$ ,  $I_{CEO}$ ,  $V_{CE(sat)}$ ,  $I_{c}$ ,  $R_{ISO}$ ,  $V_{iso}$

#### (2) Appearance

### 5.2 Sampling method and Inspection level

A single sampling plan, normal inspection level II based on ISO 2859 is applied.

The AQL according to the inspection items are shown below.

Defect	Inspection item	AQL(%)
Major defect	Electrical characteristics Unreadable marking	0.065
Minor defect	Appearance defect except the above mentioned.	0.25

6.2 Package specifications

6.2.1 Taping conditions

- (1) Tape structure and Dimensions (Refer to the attached sheet, Page 9)
  - The carrier tape has the heat pressed structure of PS material carries tape and three layers cover tape (PET material base).
- (2) Reel structure and Dimensions (Refer to the attached sheet, Page 10)
  - The taping reel shall be of plastic (PS material).
- (3) Direction of product insertion (Refer to the attached sheet, Page 10)
- (4) Joint of tape
  - The cover tape and carrier tape in one reel shall be joint less.
- (5) To repair failure-taped devices, cutting a bottom of carrier tape with a cutter.
  - After replacing the cut portion shall be sealed with adhesive tape.

6.2.2 Adhesiveness of cover tape

- The exfoliation force between carrier tape and cover tape shall be 0.2N to 0.7N for the angle 160° to 180° .

6.2.3 Rolling method and quantity

- Wind the tape back on the reel so that the cover tape will be outside the tape.
- Attach more than 20cm of blank tape to the trailer and the leader of the and fix the both ends with adhesive tape. One reel basically shall contain 2000pcs.

6.2.4 Outer packing appearance

- Refer to the attached sheet, page 10.

6.2.5 Marking

The label with following information shall be pasted at appointed place of the outer packing case.

- \* Model No. \*(Business dealing name) \* Lot No. \* Quantity
- \* Country of origin \*Company name \*Inspection date specified

6.2.6 Storage condition

- Taped products shall be stored at the temperature 5 to 30°C and the humidity 70%RH or less away from direct sunlight.

6.2.7 Safety protection during shipping

- There shall be no deformation of component or degradation of electrical characteristics due to shipping.

Carrier tape structure and Dimensions

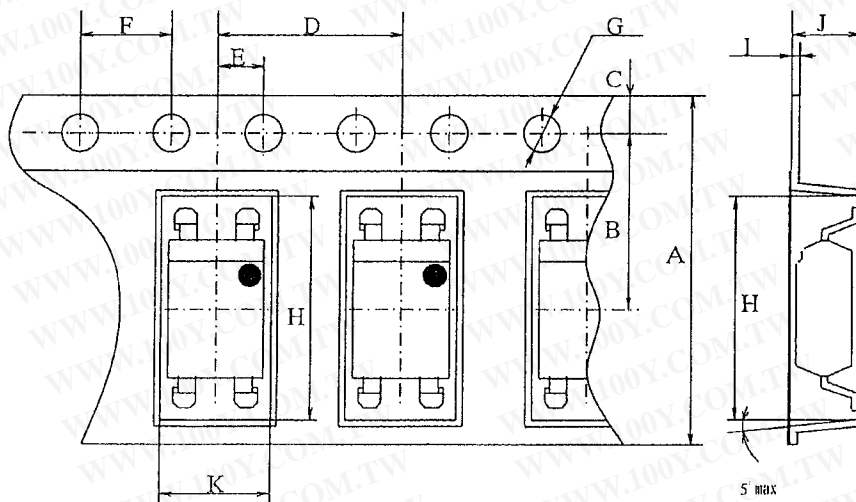

Dimensions list (Unit : mm)

A	B	C	D	E	F	G	H	I	J	K
±0.3	±0.1	±0.10	±0.1	±0.1	±0.1	+0.1 -0.0	±0.1	±0.05	±0.1	±0.1
16.0	7.5	1.75	8.0	2.0	4.0	φ1.5	10.4	0.40	4.2	5.1

# PC817X-NIP0F REFERENCE

## Reel structure and Dimensions

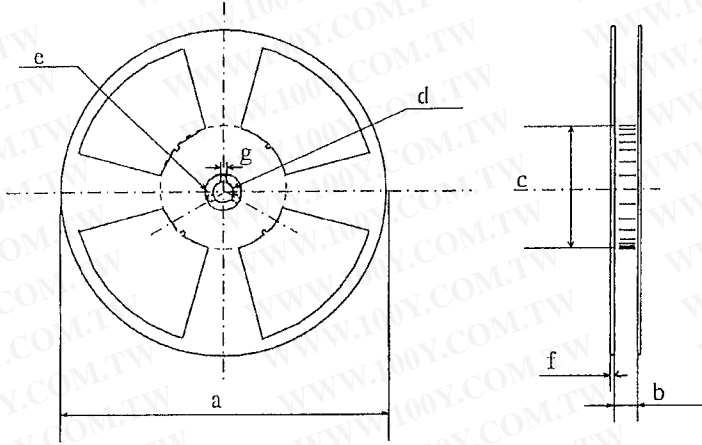

Dimensions list (Unit : mm)

a	b	c	d
(330)	17.5±1.5	φ100.0±1.0	φ13.0±0.5
e	f	g	
φ23.0±1.0	2.0±0.5	2.0±0.5	

## Direction of product insertion

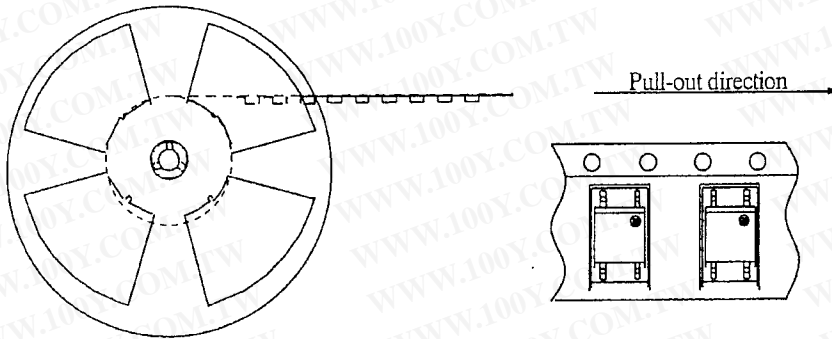

## Outer packing appearance

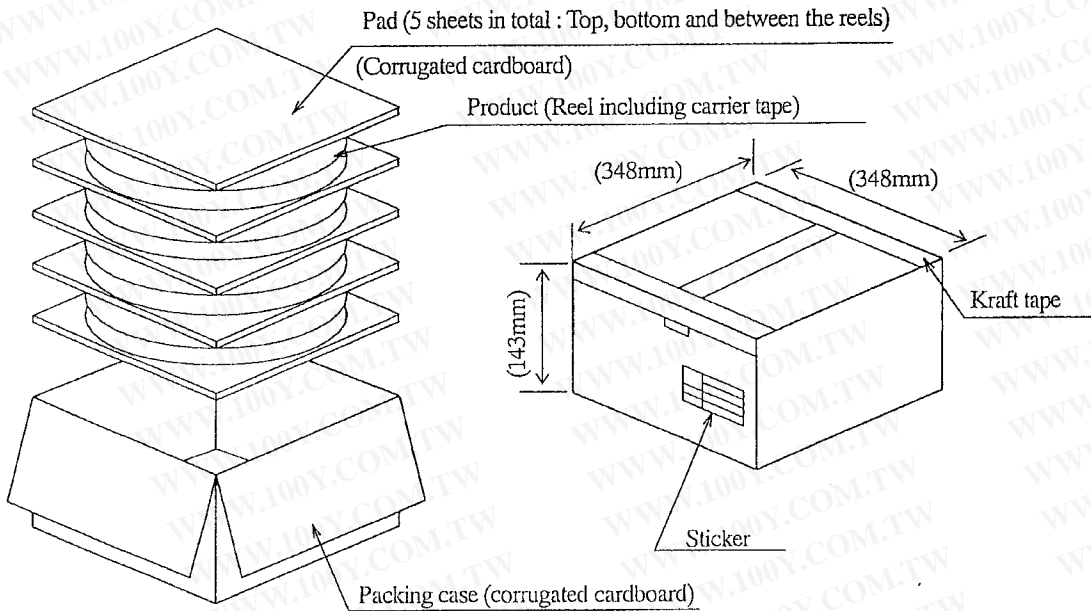

Regular packing mass : Approx. 4.1kg

( ) : Reference dimensions

### 1. Cleaning

- (1) Solvent cleaning : Solvent temperature 45°C or less  
Immersion for 3 min or less
- (2) Ultrasonic cleaning : The effect to device by ultrasonic cleaning differs by cleaning bath size, ultrasonic power output, cleaning time, PCB size or device mounting condition etc. Please test it in actual using condition and confirm that any defect doesn't occur before starting the ultrasonic cleaning.
- (3) Applicable solvent : Ethyl alcohol, Methyl alcohol, Isopropyl alcohol  
When the other solvent is used, there are cases that the packaging resin is eroded.  
Please use the other solvent after thorough confirmation is performed in actual using condition.

### 2. Circuit design

- (1) The LED used in the Photocoupler generally decreases the light emission power by operation.  
In case of long operation time, please design the circuit in consideration of the degradation of the light emission power of the LED. (50%/5years)
- (2) There are cases that the deviation of the CTR and the degradation of the relative light emission power of the LED increase when the setting value of  $I_F$  is less than 1.0mA. Please design the circuit in consideration of this point.

### 3. Precautions for Soldering

- (1) In the case of flow soldering (Whole device dipping .)  
It is recommended that flow soldering should be at 270°C or less for 10 s or less  
(Pre-heating : 100 to 150°C, 30 to 80s). (2 times or less)
- (2) If solder reflow :  
It is recommended to be done at the temperature and the time within the temperature profile as shown in the figure below. (2 times or less)

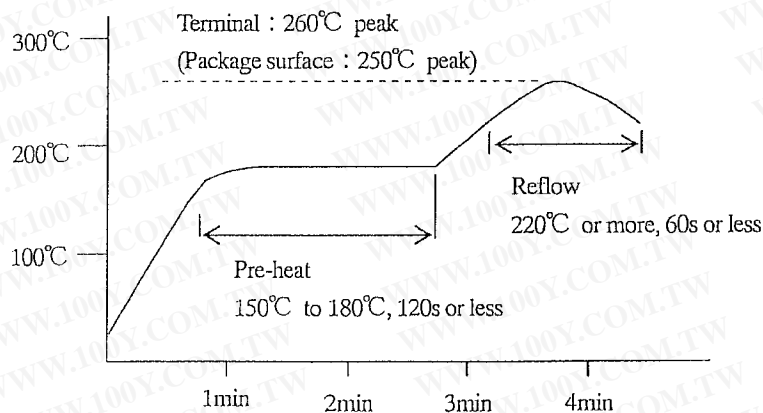

- (3) In the case of hand soldering  
What is done on the following condition is recommended. (2 times or less)  
Soldering iron temperature : 400°C or less  
Time : 3s or less
- (4) Other precautions  
Depending on equipment and soldering conditions (temperature, Using solder etc.),  
the effect to the device and the PCB is different.  
Please confirm that there is no problem on the actual use conditions in advance.