



勝特力材料 886-3-5753170  
 勝特力电子(上海) 86-21-54151736  
 勝特力电子(深圳) 86-755-83298787  
 Http://www.100y.com.tw

# 24LC01B/02B

## 1K/2K 2.5V I<sup>2</sup>C™ Serial EEPROM

### FEATURES

- Single supply with operation down to 2.5V
- Low power CMOS technology
  - 1 mA active current typical
  - 10  $\mu$ A standby current typical at 5.5V
  - 5  $\mu$ A standby current typical at 3.0V
- Organized as a single block of 128 bytes (128 x 8) -1K or 256 bytes (256 x 8) -2K
- 2-wire serial interface bus, I<sup>2</sup>C™ compatible
- Schmitt trigger inputs for noise suppression
- 100 kHz (E-temp.) and 400 kHz (C/I-temp.) compatibility
- Self-timed write cycle (including auto-erase)
- Page-write buffer for up to 8 bytes
- 2 ms typical write cycle time for page-write
- Hardware write protect for entire memory
- Can be operated as a serial ROM
- ESD protection > 3,000V
- 1,000,000 E/W cycles ensured
- Data retention > 200 years
- 8-pin DIP, SOIC, TSSOP or SOT-23\* package
  - Commercial (C): 0°C to +70°C
  - Industrial (I): -40°C to +85°C
  - Automotive (E): -40°C to +125°C
- Available for temperature ranges

### DESCRIPTION

The Microchip Technology Inc. 24LC01B and 24LC02B are 1 Kbit and 2 Kbit Electrically Erasable PROMs (EEPROMs). The devices are organized as a single block of 128 x 8-bit or 256 x 8-bit memory with a 2-wire serial interface. Low voltage design permits operation down to 2.5 volts with a standby and active currents of only 5  $\mu$ A and 1 mA respectively. The 24LC01B and 24LC02B also have page-write capability for up to 8 bytes of data. The 24LC01B and 24LC02B are available in the standard 8-pin DIP, 8-lead surface mount SOIC, MSOP and TSSOP packages. The SOT-23 package is available for the 24LC01B.

\*Available for 24LC01B only

I<sup>2</sup>C is a trademark of Philips Corporation.

### PACKAGE TYPES

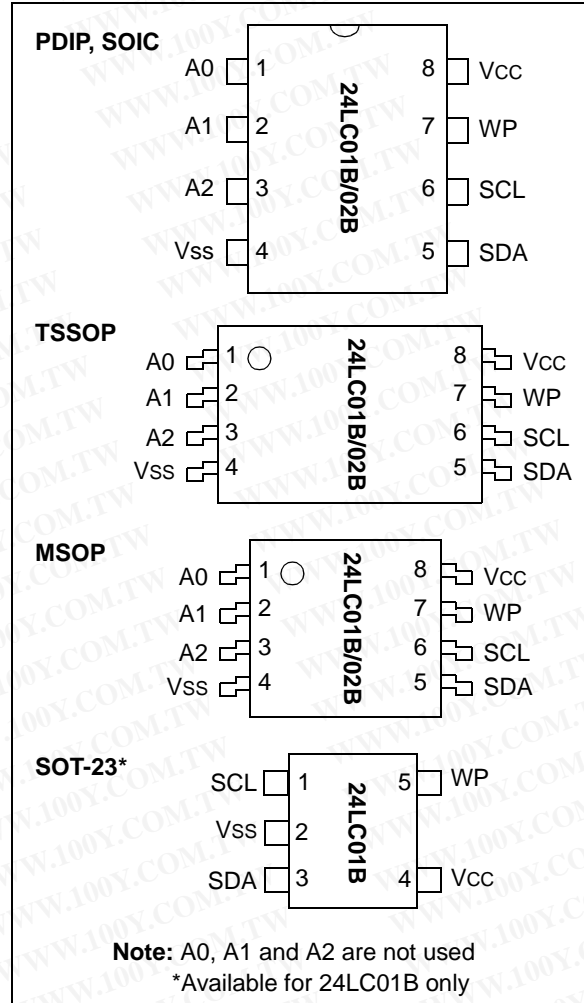

### BLOCK DIAGRAM

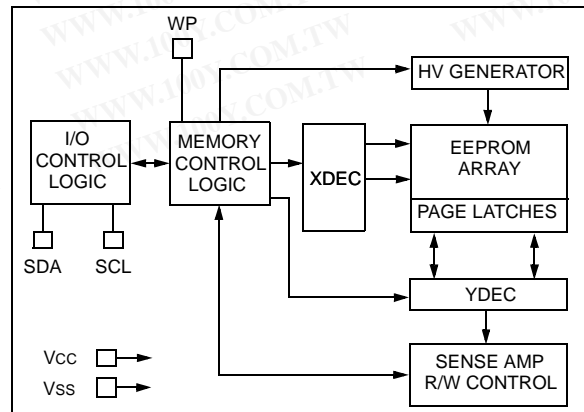

# 24LC01B/02B

## 1.0 ELECTRICAL CHARACTERISTICS

### 1.1 Maximum Ratings\*

V<sub>CC</sub>.....7.0V  
 All inputs and outputs w.r.t. V<sub>SS</sub> .....-0.6V to V<sub>CC</sub> +1.0V  
 Storage temperature .....-65°C to +150°C  
 Ambient temp. with power applied .....-65°C to +125°C  
 Soldering temperature of leads (10 seconds) .. +300°C  
 ESD protection on all pins ..... > 3 kV

**\*Notice:** Stresses above those listed under “Maximum ratings” may cause permanent damage to the device. This is a stress rating only and functional operation of the device at those or any other conditions above those indicated in the operational listings of this specification is not implied. Exposure to maximum rating conditions for extended periods may affect device reliability.

TABLE 1-1: PIN FUNCTION TABLE

Name	Function
V <sub>SS</sub>	Ground
SDA	Serial Address/Data I/O
SCL	Serial Clock
WP	Write Protect Input
V <sub>CC</sub>	+2.5V to 5.5V Power Supply
A0, A1, A2	<b>No Internal Connection</b>

勝特力材料 886-3-5753170  
 勝特力电子(上海) 86-21-54151736  
 勝特力电子(深圳) 86-755-83298787  
[Http://www.100y.com.tw](http://www.100y.com.tw)

TABLE 1-2: DC CHARACTERISTICS

Parameter	Symbol	Commercial (C): T <sub>AMB</sub> = 0°C to +70°C				Conditions
		Min.	Max.	Units		
V <sub>CC</sub> = +2.5V to +5.5V		Industrial (I): T <sub>AMB</sub> = -40°C to +85°C				
		Automotive (E): T <sub>AMB</sub> = -40°C to +125°C				
WP, SCL and SDA pins:						
High level input voltage	V <sub>IH</sub>	.7 V <sub>CC</sub>	—	V	—	
Low level input voltage	V <sub>IL</sub>	—	.3 V <sub>CC</sub>	V	—	
Hysteresis of Schmidt trigger inputs	V <sub>HYS</sub>	.05 V <sub>CC</sub>	—	V	<b>(Note)</b>	
Low level output voltage	V <sub>OL</sub>	—	.40	V	I <sub>OL</sub> = 3.0 mA, V <sub>CC</sub> = 2.5V	
Input leakage current	I <sub>LI</sub>	-10	10	μA	V <sub>IN</sub> = 0.1V to 5.5V	
Output leakage current	I <sub>LO</sub>	-10	10	μA	V <sub>OUT</sub> = 0.1V to 5.5V	
Pin capacitance (all inputs/outputs)	C <sub>IN</sub> , C <sub>OUT</sub>	—	10	pF	V <sub>CC</sub> = 5.0V <b>(Note)</b> T <sub>AMB</sub> = 25°C, F <sub>CLK</sub> = 1 MHz	
Operating current	I <sub>CC</sub> Write	—	3	mA	V <sub>CC</sub> = 5.5V, SCL = 400 kHz	
	I <sub>CC</sub> Read	—	1	mA	—	
Standby current	I <sub>CCS</sub>	—	30	μA	V <sub>CC</sub> = 3.0V, SDA = SCL = V <sub>CC</sub>	
		—	100	μA	V <sub>CC</sub> = 5.5V, SDA = SCL = V <sub>CC</sub> WP = V <sub>SS</sub>	

**Note:** This parameter is periodically sampled and not 100% tested.

FIGURE 1-1: BUS TIMING START/STOP

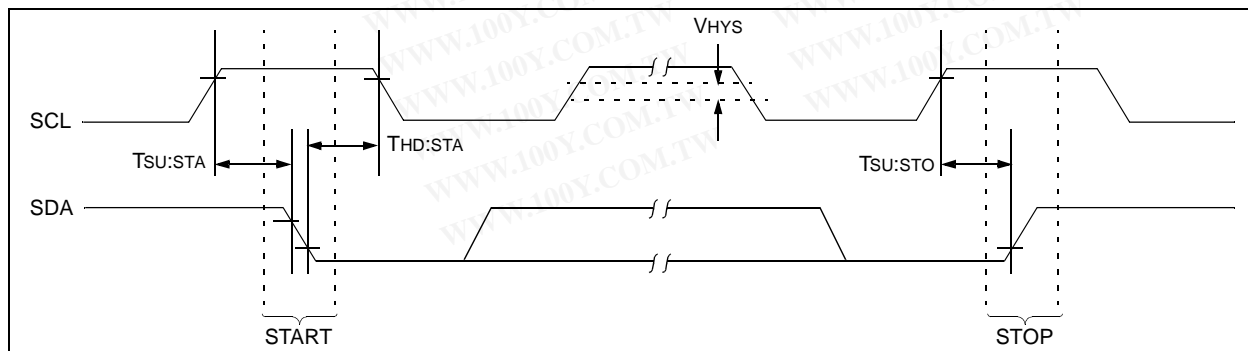

**TABLE 1-3: AC CHARACTERISTICS**

Vcc = +2.5V to 5.5V		Commercial (C): Industrial (I): Automotive (E):		TAMB = 0°C to +70°C TAMB = -40°C to +85°C TAMB = -40°C to 125°C	
Parameter	Symbol	Min	Max	Units	Conditions
Clock frequency	FCLK	— —	400 100	kHz	4.5V ≤ Vcc ≤ 5.5V 2.5V ≤ Vcc ≤ 5.5V (E-temp. range)
Clock high time	THIGH	600 4000	— —	ns	4.5V ≤ Vcc ≤ 5.5V 2.5V ≤ Vcc ≤ 5.5V (E-temp. range)
Clock low time	TLOW	1300 4700	— —	ns	4.5V ≤ Vcc ≤ 5.5V 2.5V ≤ Vcc ≤ 5.5V (E-temp. range)
SDA and SCL rise time (Note 1)	TR	— —	300 1000	ns	4.5V ≤ Vcc ≤ 5.5V (Note 1) 2.5V ≤ Vcc ≤ 5.5V (E-temp. range) (Note 1)
SDA and SCL fall time	TF	—	300	ns	(Note 1)
START condition hold time	THD:STA	600 4000	— —	ns	4.5V ≤ Vcc ≤ 5.5V 2.5V ≤ Vcc ≤ 5.5V (E-temp. range)
START condition setup time	TSU:STA	600 4700	— —	ns	4.5V ≤ Vcc ≤ 5.5V 2.5V ≤ Vcc ≤ 5.5V (E-temp. range)
Data input hold time	THD:DAT	0	—	ns	(Note 2)
Data input setup time	TSU:DAT	100 250	— —	ns	4.5V ≤ Vcc ≤ 5.5V 2.5V ≤ Vcc ≤ 5.5V (E-temp. range)
STOP condition setup time	TSU:STO	600 4000	— —	ns	4.5V ≤ Vcc ≤ 5.5V 2.5V ≤ Vcc ≤ 5.5V (E-temp. range)
Output valid from clock (Note 2)	TAA	— —	900 3500	ns	4.5V ≤ Vcc ≤ 5.5V 2.5V ≤ Vcc ≤ 5.5V (E-temp. range)
Bus free time: Time the bus must be free before a new transmission can start	TBUF	1300 4700	— —	ns	4.5V ≤ Vcc ≤ 5.5V 2.5V ≤ Vcc ≤ 5.5V (E-temp. range)
Output fall time from VIH minimum to VIL maximum	TOF	20+0.1CB —	250 250	ns	4.5V ≤ Vcc ≤ 5.5V (Note 1) 2.5V ≤ Vcc ≤ 5.5V (E-temp. range) (Note 1)
Input filter spike suppression (SDA and SCL pins)	TSP	—	50	ns	(Notes 1 and 3)
Write cycle time (byte or page)	TWC	—	5	ms	—
Endurance		1M	—	cycles	25°C, Vcc = 5.0V, Block Mode (Note 4)

**Note 1:** Not 100% tested. CB = total capacitance of one bus line in pF.

- 2:** As a transmitter, the device must provide an internal minimum delay time to bridge the undefined region (minimum 300 ns) of the falling edge of SCL to avoid unintended generation of START or STOP conditions.
- 3:** The combined TSP and VHYS specifications are due to new Schmitt trigger inputs which provide improved noise spike suppression. This eliminates the need for a TI specification for standard operation.
- 4:** This parameter is not tested but ensured by characterization. For endurance estimates in a specific application, please consult the Total Endurance Model which can be obtained on Microchip's website: [www.microchip.com](http://www.microchip.com).

勝特力材料 886-3-5753170  
 勝特力电子(上海) 86-21-54151736  
 勝特力电子(深圳) 86-755-83298787  
[Http://www.100y.com.tw](http://www.100y.com.tw)

# 24LC01B/02B

勝特力材料 886-3-5753170  
勝特力电子(上海) 86-21-54151736  
勝特力电子(深圳) 86-755-83298787  
[Http://www.100y.com.tw](http://www.100y.com.tw)

FIGURE 1-2: BUS TIMING DATA

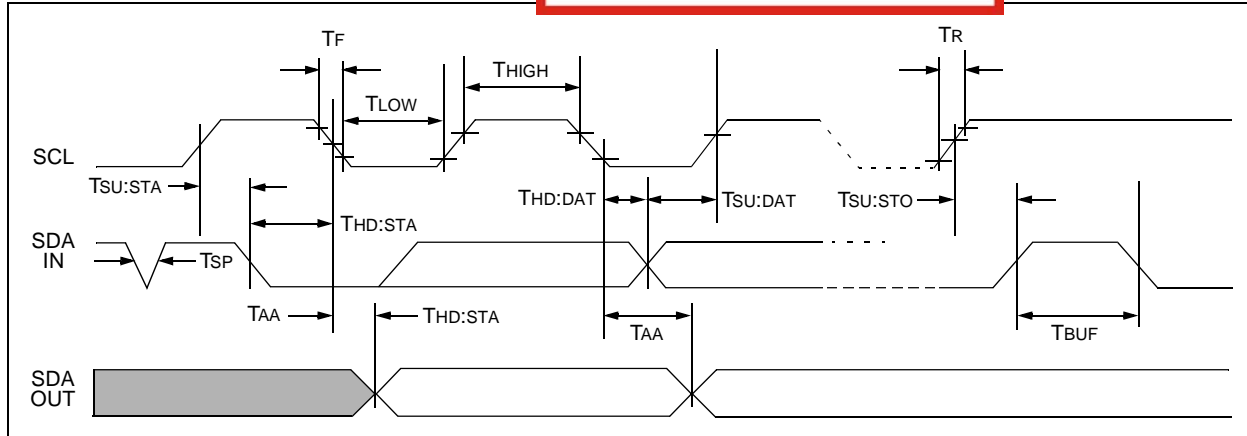



## 2.0 FUNCTIONAL DESCRIPTION

The 24LC01B/02B supports a bi-directional 2-wire bus and data transmission protocol. A device that sends data onto the bus is defined as transmitter and if receiving data, as receiver. The bus has to be controlled by a master device which generates the serial clock (SCL), controls the bus access and generates the START and STOP conditions, while the 24LC01B/02B works as slave. Both master and slave can operate as transmitter or receiver, but the master device determines which mode is activated.

## 3.0 BUS CHARACTERISTICS

The following **bus protocol** has been defined:

- Data transfer may be initiated only when the bus is not busy
- During data transfer, the data line must remain stable whenever the clock line is HIGH. Changes in the data line while the clock line is HIGH will be interpreted as a START or STOP condition

Accordingly, the following bus conditions have been defined (Figure 3-1).

### 3.1 Bus Not Busy (A)

Both data and clock lines remain HIGH.

### 3.2 Start Data Transfer (B)

A HIGH to LOW transition of the SDA line while the clock (SCL) is HIGH determines a START condition. All commands must be preceded by a START condition.

### 3.3 Stop Data Transfer (C)

A LOW to HIGH transition of the SDA line while the clock (SCL) is HIGH determines a STOP condition. All operations must be ended with a STOP condition.

### 3.4 Data Valid (D)

The state of the data line represents valid data when, after a START condition, the data line is stable for the duration of the HIGH period of the clock signal.

The data on the line must be changed during the LOW period of the clock signal. There is one clock pulse per bit of data.

Each data transfer is initiated with a START condition and terminated with a STOP condition. The number of the data bytes transferred between the START and STOP conditions is determined by the master device and is theoretically unlimited, although only the last sixteen will be stored when doing a write operation. When an overwrite does occur it will replace data in a first in first out fashion.

### 3.5 Acknowledge

Each receiving device, when addressed, is obliged to generate an acknowledge after the reception of each byte. The master device must generate an extra clock pulse which is associated with this acknowledge bit.

**Note:** The 24LC01B/02B does not generate any acknowledge bits if an internal programming cycle is in progress.

The device that acknowledges has to pull down the SDA line during the acknowledge clock pulse in such a way that the SDA line is stable LOW during the HIGH period of the acknowledge related clock pulse. Of course, setup and hold times must be taken into account. A master must signal an end of data to the slave by not generating an acknowledge bit on the last byte that has been clocked out of the slave. In this case, the slave must leave the data line HIGH to enable the master to generate the STOP condition.

**FIGURE 3-1: DATA TRANSFER SEQUENCE ON THE SERIAL BUS**

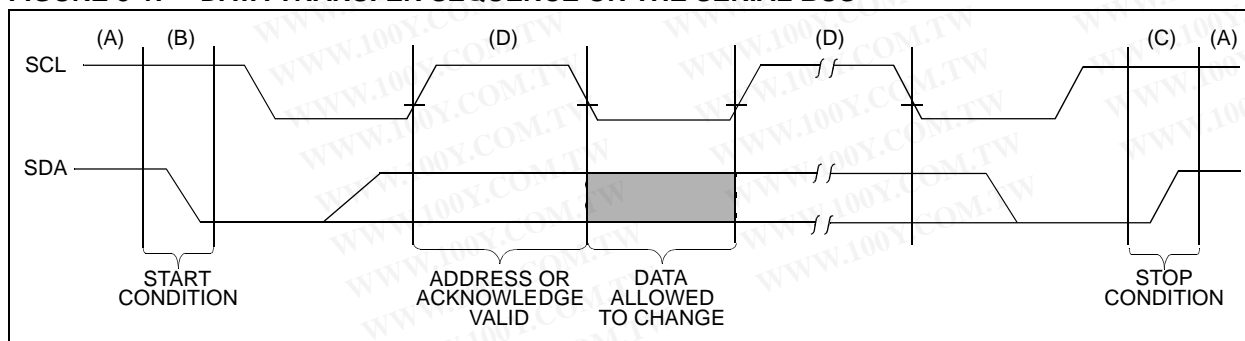

勝特力材料 886-3-5753170  
 勝特力电子(上海) 86-21-54151736  
 勝特力电子(深圳) 86-755-83298787  
[Http://www.100y.com.tw](http://www.100y.com.tw)

# 24LC01B/02B

## 3.6 Device Address

The 24LC01B/02B are software-compatible with older devices such as 24C01A, 24C02A, 24LC01 and 24LC02. A single 24LC02B can be used in place of two 24LC01's, for example, without any modifications to software. The "chip select" portion of the control byte becomes a 'don't care'.

After generating a START condition, the bus master transmits the slave address consisting of a 4-bit device code (1010) for the 24LC01B/02B, followed by three 'don't care' bits.

The eighth bit of slave address determines if the master device wants to read or write to the 24LC01B/02B (Figure 3-2).

The 24LC01B/02B monitors the bus for its corresponding slave address all the time. It generates an acknowledge bit if the slave address was true and it is not in a programming mode.

Operation	Control Code	Chip Select	R/W
Read	1010	XXX	1
Write	1010	XXX	0

**FIGURE 3-2: CONTROL BYTE ALLOCATION**

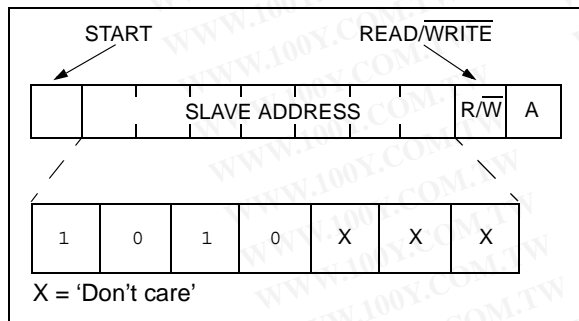

勝特力材料 886-3-5753170  
 勝特力电子(上海) 86-21-54151736  
 勝特力电子(深圳) 86-755-83298787  
[Http://www.100y.com.tw](http://www.100y.com.tw)

## 4.0 WRITE OPERATION

### 4.1 Byte Write

Following the start signal from the master, the device code (4 bits), the don't care bits (3 bits) and the R/W bit, which is a logic LOW is placed onto the bus by the master transmitter. This indicates to the addressed slave receiver that a byte with a word address will follow after it has generated an acknowledge bit, during the ninth clock cycle. Therefore, the next byte transmitted by the master is the word address and will be written into the address pointer of the 24LC01B/02B. After receiving another acknowledge signal from the 24LC01B/02B, the master device will transmit the data word to be written into the addressed memory location. The 24LC01B/02B acknowledges again and the master generates a stop condition. This initiates the internal write cycle. During this time, the 24LC01B/02B will not generate acknowledge signals (Figure 4-1).

### 4.2 Page Write

The write control byte, word address and the first data byte are transmitted to the 24LC01B/02B in the same way as in a byte write. But instead of generating a stop condition, the master transmits up to eight data bytes to the 24LC01B/02B. They are temporarily stored in the on-chip page buffer and will be written into the memory after the master has transmitted a stop condition. After the receipt of each word, the three lower order address pointer bits are internally incremented by one. The higher order five bits of the word address remains constant. If the master should transmit more than eight words prior to generating the stop condition, the address counter will roll over and the previously received data will be overwritten. As with the byte write operation, once the stop condition is received an internal write cycle will begin (Figure 4-2).

**Note:** Page write operations are limited to writing bytes within a single physical page, **regardless** of the number of bytes actually being written. Physical page boundaries start at addresses that are integer multiples of the page buffer size (or 'page size') and end at addresses that are integer multiples of [page size - 1]. If a page write command attempts to write across a physical page boundary, the result is that the data wraps around to the beginning of the current page (overwriting data previously stored there), instead of being written to the next page as might be expected. It is therefore necessary for the application software to prevent page write operations that would attempt to cross a page boundary.

**FIGURE 4-1: BYTE WRITE**

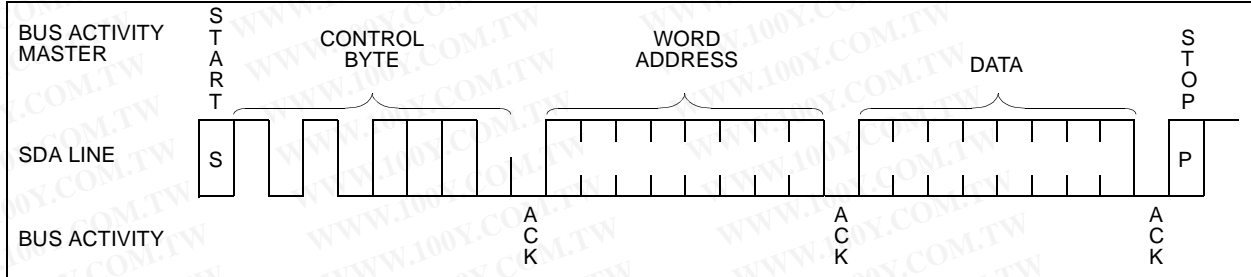

**FIGURE 4-2: PAGE WRITE**

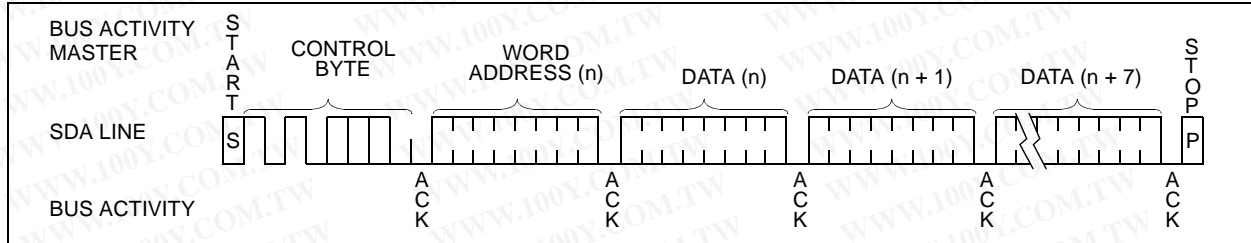

勝特力材料 886-3-5753170  
勝特力电子(上海) 86-21-54151736  
勝特力电子(深圳) 86-755-83298787  
[Http://www.100y.com.tw](http://www.100y.com.tw)



# 24LC01B/02B

## 5.0 ACKNOWLEDGE POLLING

Since the device will not acknowledge during a write cycle, this can be used to determine when the cycle is complete (this feature can be used to maximize bus throughput). Once the stop condition for a write command has been issued from the master, the device initiates the internally timed write cycle. ACK polling can be initiated immediately. This involves the master sending a start condition followed by the control byte for a write command ( $R/\overline{W} = 0$ ). If the device is still busy with the write cycle, then no ACK will be returned. If the cycle is complete, then the device will return the ACK and the master can then proceed with the next read or write command. See Figure 5-1 for flow diagram.

**FIGURE 5-1: ACKNOWLEDGE POLLING FLOW**

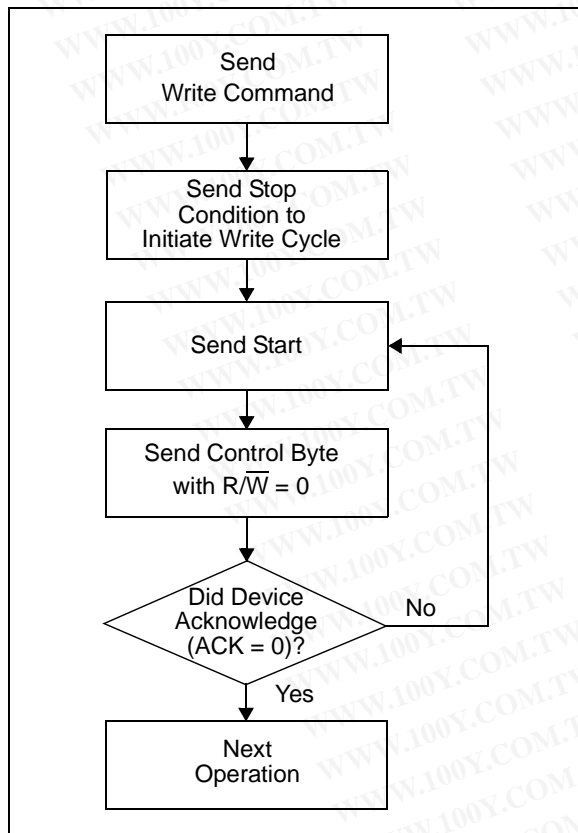

## 6.0 WRITE PROTECTION

The 24LC01B/02B can be used as a serial ROM when the WP pin is connected to VCC. Programming will be inhibited and the entire memory will be write-protected.

勝特力材料 886-3-5753170  
勝特力电子(上海) 86-21-54151736  
勝特力电子(深圳) 86-755-83298787  
[Http://www.100y.com.tw](http://www.100y.com.tw)

## 7.0 READ OPERATION

Read operations are initiated in the same way as write operations with the exception that the  $R/\overline{W}$  bit of the slave address is set to '1'. There are three basic types of read operations: current address read, random read and sequential read.

### 7.1 Current Address Read

The 24LC01B/02B contains an address counter that maintains the address of the last word accessed, internally incremented by one. Therefore, if the previous access (either a read or write operation) was to address  $n$ , the next current address read operation would access data from address  $n + 1$ . Upon receipt of the slave address with  $R/\overline{W}$  bit set to '1', the 24LC01B/02B issues an acknowledge and transmits the eight bit data word. The master will not acknowledge the transfer but does generate a stop condition and the 24LC01B/02B discontinues transmission (Figure 7-1).

### 7.2 Random Read

Random read operations allow the master to access any memory location in a random manner. To perform this type of read operation, first the word address must be set. This is done by sending the word address to the 24LC01B/02B as part of a write operation. After the word address is sent, the master generates a start condition following the acknowledge. This terminates the write operation, but not before the internal address pointer is set. Then the master issues the control byte again but with the  $R/\overline{W}$  bit set to a '1'. The 24LC01B/02B will then issue an acknowledge and transmits the 8-bit data word. The master will not acknowledge the transfer but does generate a stop condition and the 24LC01B/02B discontinues transmission (Figure 7-2).

### 7.3 Sequential Read

Sequential reads are initiated in the same way as a random read except that after the 24LC01B/02B transmits the first data byte, the master issues an acknowledge as opposed to a stop condition in a random read. This directs the 24LC01B/02B to transmit the next sequentially addressed 8-bit word (Figure 7-3).

To provide sequential reads the 24LC01B/02B contains an internal address pointer which is incremented by one at the completion of each operation. This address pointer allows the entire memory contents to be serially read during one operation.

### 7.4 Noise Protection

The 24LC01B/02B employs a VCC threshold detector circuit which disables the internal erase/write logic if the VCC is below 1.5 volts at nominal conditions.

The SCL and SDA inputs have Schmitt trigger and filter circuits which suppress noise spikes to assure proper device operation even on a noisy bus.



**FIGURE 7-1: CURRENT ADDRESS READ**

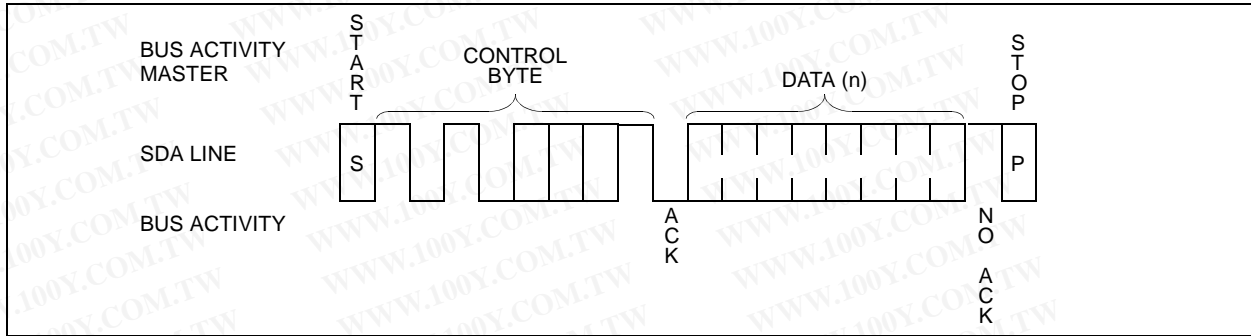

**FIGURE 7-2: RANDOM READ**

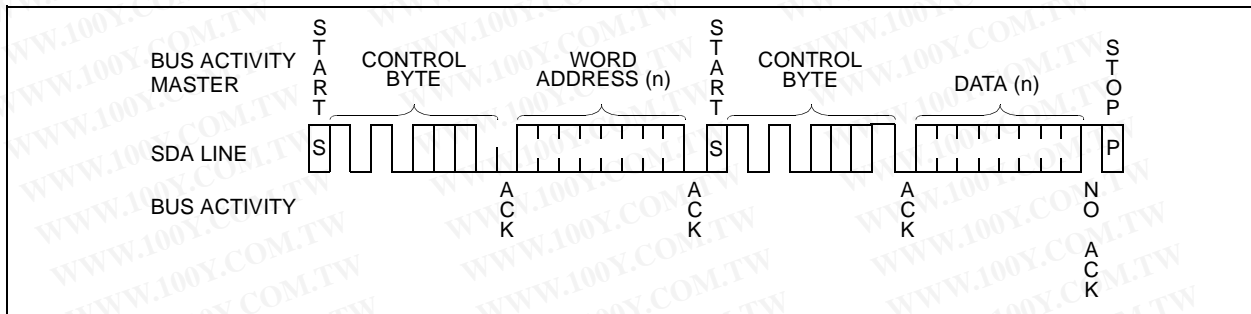

**FIGURE 7-3: SEQUENTIAL READ**

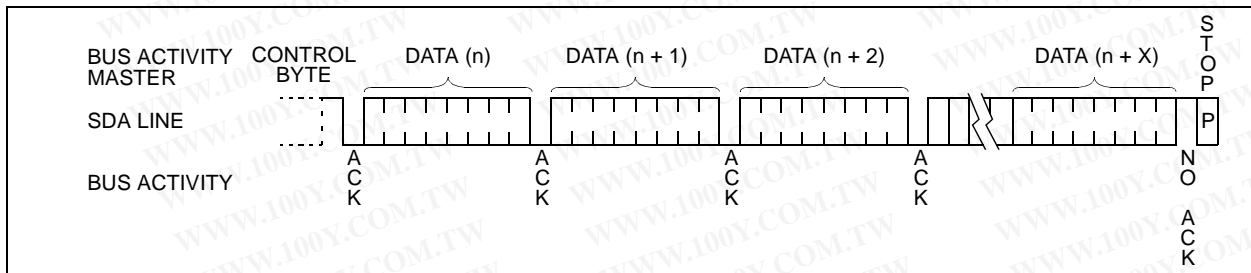

## 8.0 PIN DESCRIPTIONS

### 8.1 SDA Serial Address/Data Input/Output

This is a bi-directional pin used to transfer addresses and data into and data out of the device. It is an open drain terminal. Therefore, the SDA bus requires a pull-up resistor to Vcc (typical 10kΩ for 100 kHz, 2kΩ for 400 kHz).

For normal data transfer SDA is allowed to change only during SCL LOW. Changes during SCL HIGH are reserved for indicating the START and STOP conditions.

### 8.2 SCL Serial Clock

This input is used to synchronize the data transfer from and to the device.

### 8.3 WP

This pin must be connected to either Vss or Vcc.

If tied to Vss, normal memory operation is enabled (read/write the entire memory).

If tied to Vcc, WRITE operations are inhibited. The entire memory will be write-protected. Read operations are not affected.

This feature allows the user to use the 24LC01B/02B as a serial ROM when WP is enabled (tied to Vcc).

### 8.4 A0, A1, A2

These pins are not used by the 24LC01B/02B. They may be left floating or tied to either Vss or Vcc.

勝特力材料 886-3-5753170  
 勝特力电子(上海) 86-21-54151736  
 勝特力电子(深圳) 86-755-83298787  
[Http://www.100y.com.tw](http://www.100y.com.tw)

## 9.0 PACKAGING INFORMATION

### 9.1 Package Marking Information

#### 8-Lead PDIP (300 mil)



#### Example



#### 8-Lead SOIC (150 mil)

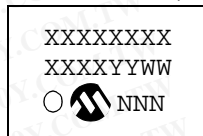

#### Example



#### 5-Lead SOT-23 (24LC01B only)



#### Example



#### 8-Lead TSSOP



#### Example



#### 8-Lead MSOP



#### Example

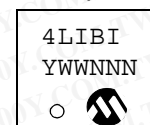

**Legend:** XX...X Customer specific information\*  
 Y Year code (last digit of calendar year)  
 YY Year code (last 2 digits of calendar year)  
 WW Week code (week of January 1 is week '01')  
 NNN Alphanumeric traceability code

**Note:** In the event the full Microchip part number cannot be marked on one line, it will be carried over to the next line thus limiting the number of available characters for customer specific information.

\* Standard PICmicro device marking consists of Microchip part number, year code, week code and traceability code. For PICmicro device marking beyond this, certain price adders apply. Please check with your Microchip Sales Office. For QTP devices, any special marking adders are included in QTP price.

# 24LC01B/02B

## 8-Lead Plastic Dual In-line (P) – 300 mil (PDIP)

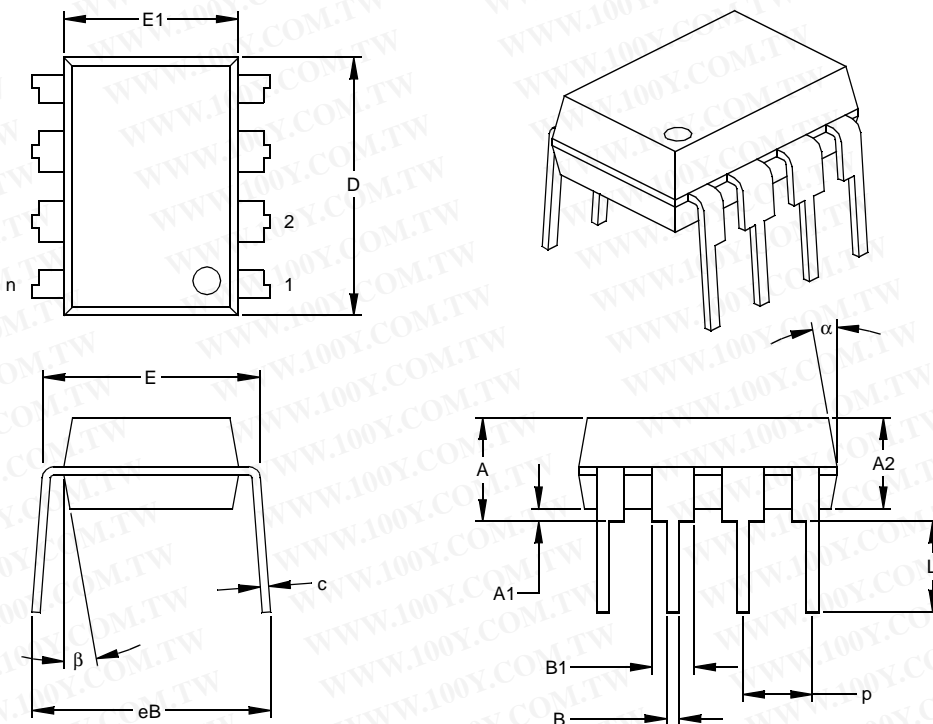

Dimension Limits	Units	INCHES*			MILLIMETERS		
		MIN	NOM	MAX	MIN	NOM	MAX
Number of Pins	n		8			8	
Pitch	p		.100			2.54	
Top to Seating Plane	A	.140	.155	.170	3.56	3.94	4.32
Molded Package Thickness	A2	.115	.130	.145	2.92	3.30	3.68
Base to Seating Plane	A1	.015			0.38		
Shoulder to Shoulder Width	E	.300	.313	.325	7.62	7.94	8.26
Molded Package Width	E1	.240	.250	.260	6.10	6.35	6.60
Overall Length	D	.360	.373	.385	9.14	9.46	9.78
Tip to Seating Plane	L	.125	.130	.135	3.18	3.30	3.43
Lead Thickness	c	.008	.012	.015	0.20	0.29	0.38
Upper Lead Width	B1	.045	.058	.070	1.14	1.46	1.78
Lower Lead Width	B	.014	.018	.022	0.36	0.46	0.56
Overall Row Spacing	eB	.310	.370	.430	7.87	9.40	10.92
Mold Draft Angle Top	$\alpha$	5	10	15	5	10	15
Mold Draft Angle Bottom	$\beta$	5	10	15	5	10	15

\* Controlling Parameter  
 § Significant Characteristic

**Notes:**

Dimensions D and E1 do not include mold flash or protrusions. Mold flash or protrusions shall not exceed .010" (0.254mm) per side.  
 JEDEC Equivalent: MS-001  
 Drawing No. C04-018

勝特力材料 886-3-5753170  
 勝特力电子(上海) 86-21-54151736  
 勝特力电子(深圳) 86-755-83298787  
[Http://www.100y.com.tw](http://www.100y.com.tw)

# 24LC01B/02B

## 8-Lead Plastic Small Outline (SN) – Narrow, 150 mil (SOIC)

勝特力材料 886-3-5753170  
 勝特力电子(上海) 86-21-54151736  
 勝特力电子(深圳) 86-755-83298787  
[Http://www.100y.com.tw](http://www.100y.com.tw)

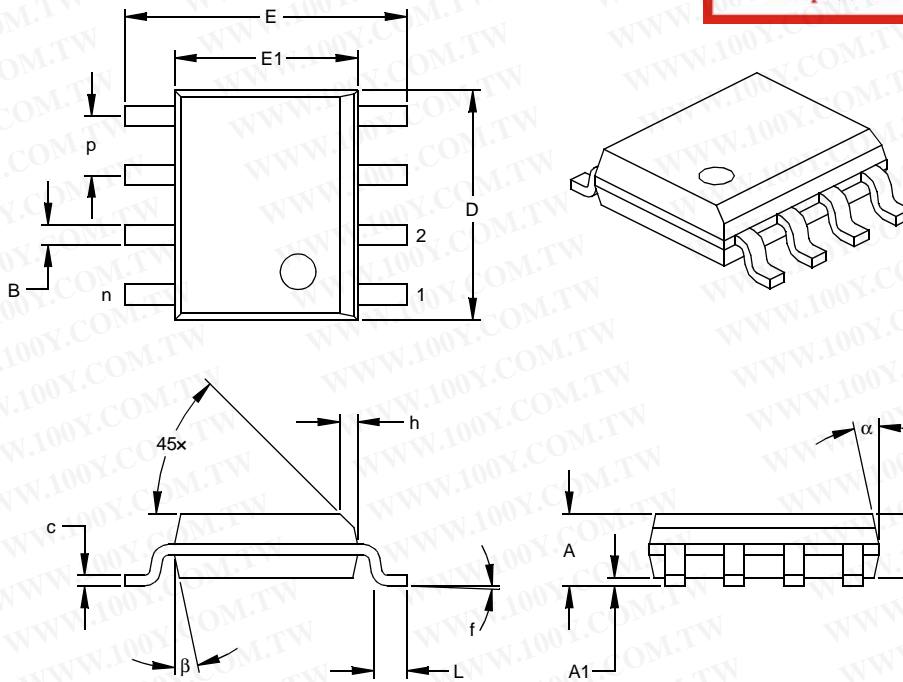

Dimension Limits	Units	INCHES*			MILLIMETERS		
		MIN	NOM	MAX	MIN	NOM	MAX
Number of Pins	n		8			8	
Pitch	p		.050			1.27	
Overall Height	A	.053	.061	.069	1.35	1.55	1.75
Molded Package Thickness	A2	.052	.056	.061	1.32	1.42	1.55
Standoff §	A1	.004	.007	.010	0.10	0.18	0.25
Overall Width	E	.228	.237	.244	5.79	6.02	6.20
Molded Package Width	E1	.146	.154	.157	3.71	3.91	3.99
Overall Length	D	.189	.193	.197	4.80	4.90	5.00
Chamfer Distance	h	.010	.015	.020	0.25	0.38	0.51
Foot Length	L	.019	.025	.030	0.48	0.62	0.76
Foot Angle	f	0	4	8	0	4	8
Lead Thickness	c	.008	.009	.010	0.20	0.23	0.25
Lead Width	B	.013	.017	.020	0.33	0.42	0.51
Mold Draft Angle Top	$\alpha$	0	12	15	0	12	15
Mold Draft Angle Bottom	$\beta$	0	12	15	0	12	15

\* Controlling Parameter  
 § Significant Characteristic

### Notes:

Dimensions D and E1 do not include mold flash or protrusions. Mold flash or protrusions shall not exceed .010" (0.254mm) per side.  
 JEDEC Equivalent: MS-012  
 Drawing No. C04-057



# 24LC01B/02B

## 8-Lead Plastic Thin Shrink Small Outline (ST) – 4.4 mm (TSSOP)

勝特力材料 886-3-5753170  
 勝特力电子(上海) 86-21-54151736  
 勝特力电子(深圳) 86-755-83298787  
[Http://www.100y.com.tw](http://www.100y.com.tw)

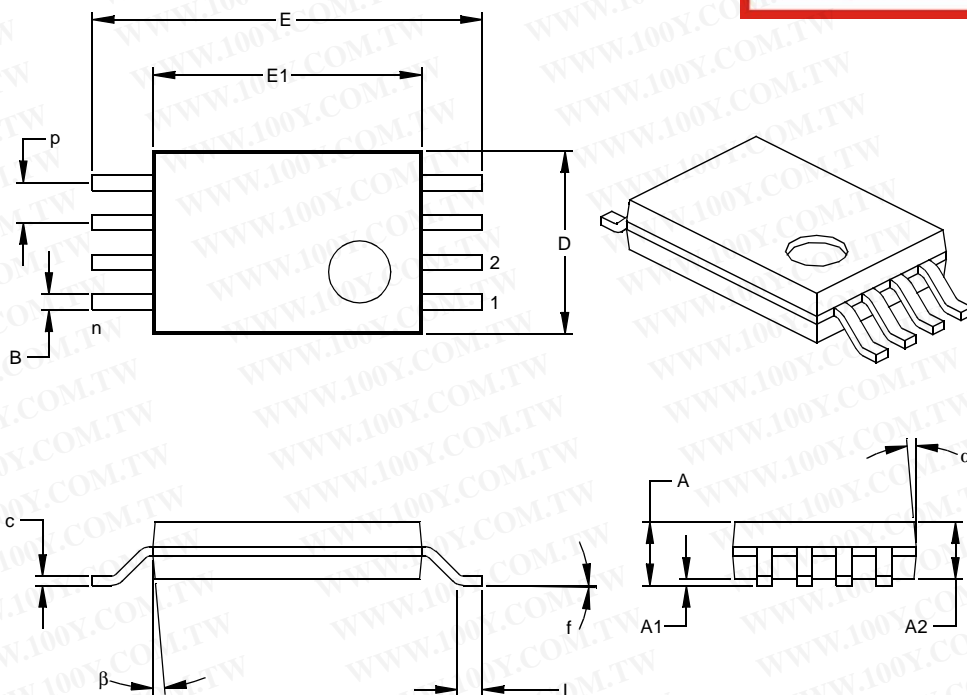

Dimension Limits	Units	INCHES			MILLIMETERS*		
		MIN	NOM	MAX	MIN	NOM	MAX
Number of Pins	n			8			8
Pitch	p		.026			0.65	
Overall Height	A			.043			1.10
Molded Package Thickness	A2	.033	.035	.037	0.85	0.90	0.95
Standoff §	A1	.002	.004	.006	0.05	0.10	0.15
Overall Width	E	.246	.251	.256	6.25	6.38	6.50
Molded Package Width	E1	.169	.173	.177	4.30	4.40	4.50
Molded Package Length	D	.114	.118	.122	2.90	3.00	3.10
Foot Length	L	.020	.024	.028	0.50	0.60	0.70
Foot Angle	f	0	4	8	0	4	8
Lead Thickness	c	.004	.006	.008	0.09	0.15	0.20
Lead Width	B	.007	.010	.012	0.19	0.25	0.30
Mold Draft Angle Top	α	0	5	10	0	5	10
Mold Draft Angle Bottom	β	0	5	10	0	5	10

\* Controlling Parameter  
 § Significant Characteristic

### Notes:

Dimensions D and E1 do not include mold flash or protrusions. Mold flash or protrusions shall not exceed .005" (0.127mm) per side.

JEDEC Equivalent: MO-153

Drawing No. C04-086

# 24LC01B/02B

## 5-Lead Plastic Small Outline Transistor (OT) (SOT23)

勝特力材料 886-3-5753170  
 勝特力电子(上海) 86-21-54151736  
 勝特力电子(深圳) 86-755-83298787  
[Http://www.100y.com.tw](http://www.100y.com.tw)

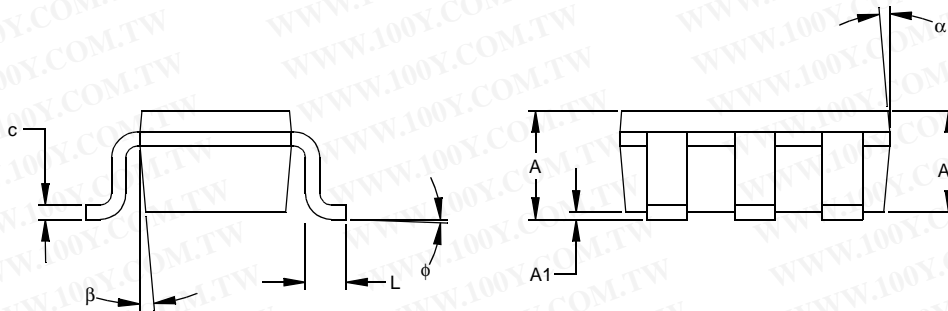
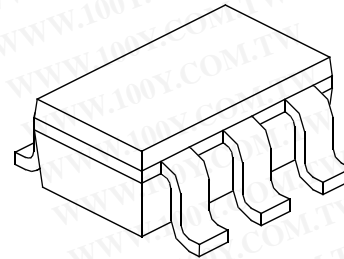
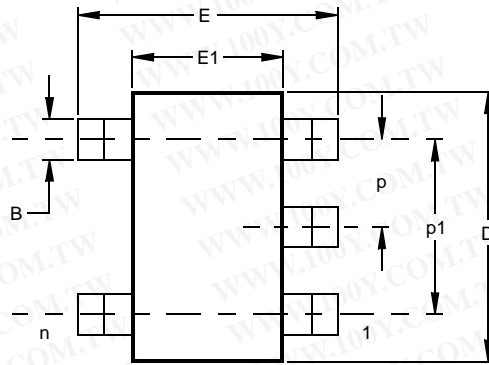

Units		INCHES*			MILLIMETERS		
Dimension Limits		MIN	NOM	MAX	MIN	NOM	MAX
Number of Pins	n		5			5	
Pitch	p		.038			0.95	
Outside lead pitch (basic)	p1		.075			1.90	
Overall Height	A	.035	.046	.057	0.90	1.18	1.45
Molded Package Thickness	A2	.035	.043	.051	0.90	1.10	1.30
Standoff §	A1	.000	.003	.006	0.00	0.08	0.15
Overall Width	E	.102	.110	.118	2.60	2.80	3.00
Molded Package Width	E1	.059	.064	.069	1.50	1.63	1.75
Overall Length	D	.110	.116	.122	2.80	2.95	3.10
Foot Length	L	.014	.018	.022	0.35	0.45	0.55
Foot Angle	$\phi$	0	5	10	0	5	10
Lead Thickness	c	.004	.006	.008	0.09	0.15	0.20
Lead Width	B	.014	.017	.020	0.35	0.43	0.50
Mold Draft Angle Top	$\alpha$	0	5	10	0	5	10
Mold Draft Angle Bottom	$\beta$	0	5	10	0	5	10

\* Controlling Parameter

§ Significant Characteristic

### Notes:

Dimensions D and E1 do not include mold flash or protrusions. Mold flash or protrusions shall not exceed .010" (0.254mm) per side.

JEDEC Equivalent: MO-178

Drawing No. C04-091

# 24LC01B/02B

## 8-Lead Plastic Micro Small Outline Package (MS) (MSOP)

勝特力材料 886-3-5753170  
 勝特力电子(上海) 86-21-54151736  
 勝特力电子(深圳) 86-755-83298787  
[Http://www.100y.com.tw](http://www.100y.com.tw)

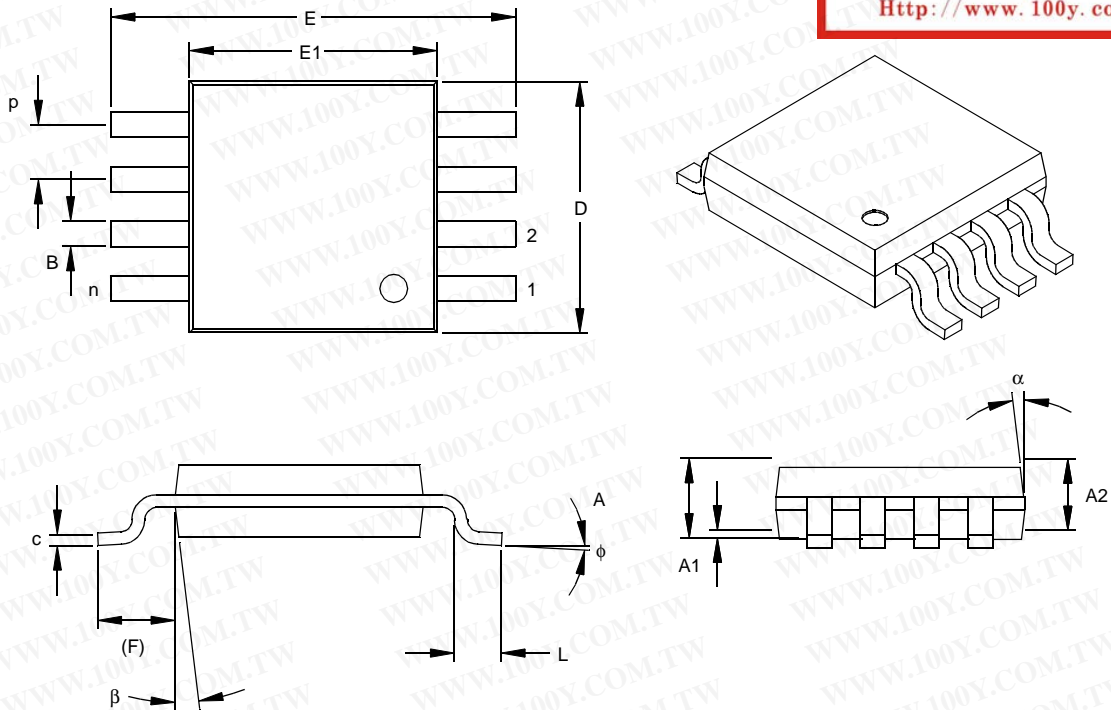

Units		INCHES			MILLIMETERS*		
Dimension Limits		MIN	NOM	MAX	MIN	NOM	MAX
Number of Pins	n		8				8
Pitch	P	.026			0.65		
Overall Height	A			.044			1.18
Molded Package Thickness	A2	.030	.034	.038	0.76	0.86	0.97
Standoff §	A1	.002		.006	0.05		0.15
Overall Width	E	.184	.193	.200	4.67	4.90	5.08
Molded Package Width	E1	.114	.118	.122	2.90	3.00	3.10
Overall Length	D	.114	.118	.122	2.90	3.00	3.10
Foot Length	L	.016	.022	.028	0.40	0.55	0.70
Footprint (Reference)	F	.035	.037	.039	0.90	0.95	1.00
Foot Angle	φ	0		6	0		6
Lead Thickness	c	.004	.006	.008	0.10	0.15	0.20
Lead Width	B	.010	.012	.016	0.25	0.30	0.40
Mold Draft Angle Top	α		7			7	
Mold Draft Angle Bottom	β		7			7	

\*Controlling Parameter  
§ Significant Characteristic

### Notes:

Dimensions D and E1 do not include mold flash or protrusions. Mold flash or protrusions shall not exceed .010" (0.254mm) per side.

Drawing No. C04-111

## ON-LINE SUPPORT

Microchip provides on-line support on the Microchip World Wide Web (WWW) site.

The web site is used by Microchip as a means to make files and information easily available to customers. To view the site, the user must have access to the Internet and a web browser, such as Netscape® or Microsoft® Explorer. Files are also available for FTP download from our FTP site.

### Connecting to the Microchip Internet Web Site

The Microchip web site is available by using your favorite Internet browser to attach to:

**[www.microchip.com](http://www.microchip.com)**

The file transfer site is available by using an FTP service to connect to:

**<ftp://ftp.microchip.com>**

The web site and file transfer site provide a variety of services. Users may download files for the latest Development Tools, Data Sheets, Application Notes, User's Guides, Articles and Sample Programs. A variety of Microchip specific business information is also available, including listings of Microchip sales offices, distributors and factory representatives. Other data available for consideration is:

- Latest Microchip Press Releases
- Technical Support Section with Frequently Asked Questions
- Design Tips
- Device Errata
- Job Postings
- Microchip Consultant Program Member Listing
- Links to other useful web sites related to Microchip Products
- Conferences for products, Development Systems, technical information and more
- Listing of seminars and events

## Systems Information and Upgrade Hot Line

The Systems Information and Upgrade Line provides system users a listing of the latest versions of all of Microchip's development systems software products. Plus, this line provides information on how customers can receive any currently available upgrade kits. The Hot Line Numbers are:

1-800-755-2345 for U.S. and most of Canada, and

1-480-792-7302 for the rest of the world.

勝特力材料 886-3-5753170  
勝特力电子(上海) 86-21-54151736  
勝特力电子(深圳) 86-755-83298787  
[Http://www.100y.com.tw](http://www.100y.com.tw)



## READER RESPONSE

It is our intention to provide you with the best documentation possible to ensure successful use of your Microchip product. If you wish to provide your comments on organization, clarity, subject matter, and ways in which our documentation can better serve you, please FAX your comments to the Technical Publications Manager at (480) 792-7578.

Please list the following information, and use this outline to provide us with your comments about this Data Sheet.

To: Technical Publications Manager Total Pages Sent  
RE: Reader Response  
From: Name \_\_\_\_\_  
Company \_\_\_\_\_  
Address \_\_\_\_\_  
City / State / ZIP / Country \_\_\_\_\_  
Telephone: (\_\_\_\_) \_\_\_\_\_ - \_\_\_\_\_ FAX: (\_\_\_\_) \_\_\_\_\_ - \_\_\_\_\_

Application (optional):

Would you like a reply? \_\_\_Y \_\_\_N

Device: **24LC01B/02B**

Literature Number: **DS20071K**

Questions:

1. What are the best features of this document?

---

---

2. How does this document meet your hardware and software development needs?

---

---

3. Do you find the organization of this data sheet easy to follow? If not, why?

---

---

4. What additions to the data sheet do you think would enhance the structure and subject?

---

---

5. What deletions from the data sheet could be made without affecting the overall usefulness?

---

---

6. Is there any incorrect or misleading information (what and where)?

---

---

7. How would you improve this document?

---

---

8. How would you improve our software, systems, and silicon products?

---

---

勝特力材料 886-3-5753170  
勝特力电子(上海) 86-21-54151736  
勝特力电子(深圳) 86-755-83298787  
[Http://www.100y.com.tw](http://www.100y.com.tw)

# 24LC01B/02B

## PRODUCT IDENTIFICATION SYSTEM

To order or obtain information, e.g., on pricing or delivery, refer to the factory or the listed sales office.

<u>PART NO.</u>	<u>X</u>	<u>/XX</u>	<u>XXX</u>	
Device	Temperature Range	Package	Pattern	
<b>Device:</b>	24LC01B: VDD range 1.8V to 5.5V 24LC01BT: (Tape and Reel) 24LC02B: VDD range 2.5V to 5.5V 24LC02BT: (Tape and Reel)			
<b>Temperature Range:</b>	- = 0°C to+70°C I = -40°C to+85°C E = -40°C to+125°C			
<b>Package:</b>	P = Plastic DIP (300 mil body), 8-lead SN = Plastic SOIC (150 mil body), 8-lead OT = SOT-23, 5-lead (24LC01B only) ST = TSSOP, 8-lead MS = MSOP, 8-lead			
<b>Examples:</b>				
a) 24LC01B-I/P Industrial Temp., PDIP package, normal VDD limits.				
b) 24LC02B/SN Commercial Temp., SOIC package, normal VDD limits.				
c) 24LC01B-I/OT Industrial Temp., SOT-23 package, normal VDD limits. (Tape and Reel only)				

## Sales and Support

### Data Sheets

Products supported by a preliminary Data Sheet may have an errata sheet describing minor operational differences and recommended workarounds. To determine if an errata sheet exists for a particular device, please contact one of the following:

1. Your local Microchip sales office
2. The Microchip Corporate Literature Center U.S. FAX: (480) 792-7277
3. The Microchip Worldwide Site ([www.microchip.com](http://www.microchip.com))

Please specify which device, revision of silicon and Data Sheet (include Literature #) you are using.

### New Customer Notification System

Register on our web site ([www.microchip.com/cn](http://www.microchip.com/cn)) to receive the most current information on our products.

勝特力材料 886-3-5753170  
勝特力电子(上海) 86-21-54151736  
勝特力电子(深圳) 86-755-83298787  
[Http://www.100y.com.tw](http://www.100y.com.tw)

勝特力材料 886-3-5753170  
勝特力电子(上海) 86-21-54151736  
勝特力电子(深圳) 86-755-83298787  
[Http://www.100y.com.tw](http://www.100y.com.tw)

"All rights reserved. Copyright © 2001, Microchip Technology Incorporated, USA. Information contained in this publication regarding device applications and the like is intended through suggestion only and may be superseded by updates. No representation or warranty is given and no liability is assumed by Microchip Technology Incorporated with respect to the accuracy or use of such information, or infringement of patents or other intellectual property rights arising from such use or otherwise. Use of Microchip's products as critical components in life support systems is not authorized except with express written approval by Microchip. No licenses are conveyed, implicitly or otherwise, under any intellectual property rights. The Microchip logo and name are registered trademarks of Microchip Technology Inc. in the U.S.A. and other countries. All rights reserved. All other trademarks mentioned herein are the property of their respective companies. No licenses are conveyed, implicitly or otherwise, under any intellectual property rights."

## Trademarks

The Microchip name, logo, PIC, PICmicro, PICMASTER, PICSTART, PRO MATE, KEELOQ, SEEVAL, MPLAB and The Embedded Control Solutions Company are registered trademarks of Microchip Technology Incorporated in the U.S.A. and other countries.

Total Endurance, ICSP, In-Circuit Serial Programming, FilterLab, MXDEV, microID, FlexROM, fuzzyLAB, MPASM, MPLINK, MPLIB, PICDEM, ICEPIC, Migratable Memory, FanSense, ECONOMONITOR, Select Mode and microPort are trademarks of Microchip Technology Incorporated in the U.S.A.

Serialized Quick Term Programming (SQTP) is a service mark of Microchip Technology Incorporated in the U.S.A.

All other trademarks mentioned herein are property of their respective companies.

© 2001, Microchip Technology Incorporated, Printed in the U.S.A., All Rights Reserved.

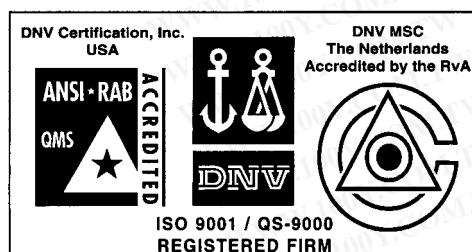

Microchip received QS-9000 quality system certification for its worldwide headquarters, design and wafer fabrication facilities in Chandler and Tempe, Arizona in July 1999. The Company's quality system processes and procedures are QS-9000 compliant for its PICmicro® 8-bit MCUs, KEELOQ® code hopping devices, Serial EEPROMs and microperipheral products. In addition, Microchip's quality system for the design and manufacture of development systems is ISO 9001 certified.