

規格承認書

SPECIFICATION FOR APPROVAL

備註 REMARKS : _____

名稱

SK2131

CUSTOMER

型號

SK01G-0500100U-USB

PART NUMBER

產品類別

电源适配器

PRODUCT

設計編號

SK-W2014082307

機種型號

SK01G-0500100U

DESIGNED NO

MODEL NO

勝特力材料 886-3-5753170
勝特力电子(上海) 86-21-34970699
勝特力电子(深圳) 86-755-83298787
[Http://www.100y.com.tw](http://www.100y.com.tw)

索引 (Index)

1. 描述 (Description)	4
2. 電氣規格 (Electrical Specification)	4
3. 保護功能 (Protection)	5
4. 可靠性 (Reliability)	5
5. 環境特性 (Environment)	6
6. 安全及 EMI 要求 (Safety and EMI Requirement)	7
7. 測試設備清單 (Test Equipment List)	8
8. 結構參數 (Mechanical Requirement)	8
9. 機械規格 (Mechanical Specifications)	9
10. 重量 (Weight)	10
11. 銘牌圖 (Label Drawing)	10
12. 包裝圖 (Package Drawing)	11

1. 描述 (Description)

本規格書適應於 SK01G-0500100U 型號的開關電源。

This specification apply to the switching power whose model no. is SK01G-0500100U

2. 電氣規格 (Electrical Specification)

2.1 輸入 (INPUT)

輸入電壓範圍 (Input voltage range)	100Vac - 240Vac
額定輸入電壓範圍 (Rated voltage range)	100Vac - 240Vac
適用頻率範圍 (Input frequency range)	47Hz-63Hz
額定頻率 (Rated input frequency)	50Hz/60Hz
輸入電流 (Input current)	0.2Amax. at full load
浪湧電流【Inrush current(cold start)】	20A typ peak, 220Vac Input

2.2 輸出 (OUTPUT)

2.2.1 額定輸出 (Rated Output)

輸出電壓 Output Voltage (Vdc)	輸出電壓範圍 Output Voltage Limit (Vdc)	紋波&雜訊 Output Ripple & Noise (mV)	最大輸出電流 Output Current (mA)
5	4.75-5.25	≤120	1000

注 (Notes): 在測試紋波時示波器頻寬調至 20MHz, 示波器的測試端並聯一粒 10uF 的電解電容和一粒 0.1uF 的瓷片電容。(Ripple Voltage is measured with oscilloscope with bandwidth 20MHz. A 10uF E-cap and 0.1uF ceramic-cap shall be connected to the connector in parallel.)

2.2.2 輸出超調 (DC Output Overshoot At Turn On & Turn Off)

輸出電壓 Output Voltage (V)	輸出超調電壓比例 Proportion of the output voltage overshoot	
	開通 Turn on	關斷 Turn off
5V	5%	5%

注 (Note): 在全部電流範圍內進行測試 (All of dc output current from Min. to Max..)

2.2.3 負載特性,調整率 (Combined Load/Line Regulation)

電壓 Voltage	最小負載 Min. Load	額定負載 Rated. Load	線性調整 Line Regulation	負載調整 Load Regulation
5Vdc	0A	1A	±3%	±5%

MODEL NO.:

SK01G-0500100U

DESIGNED NO.:

SK-W2014082307

2.2.5 啟動延遲時間 (Turn on delay time) :

當輸入 115Vac 和輸出最大負載時, 最大啟動時間為 2S.
2Second Max. at 115Vac input and output Max. load.

2.2.6 上升時間 (Rise time) :

當輸入 115Vac 和輸出最大負載時最大時間為 40mS.
40mS Max. at 115Vac input and output Max load.

2.2.7 保持時間 (Hold up time) :

當輸入 115Vac 和輸出最大負載時, 最小保持時間為 5mS.
5mS Min. at 115Vac input and output Max. Load.

2.2.8 效率 (Efficiency) :

當 230Vac 輸入時, 輸出在 25%, 50%, 75%及滿載情況下, 平均效率需達到 63.48% (開機 30 分鐘後測試).
Average efficiency reach 63.48% minimum at 25%, 50%, 75%&100% of full-loading and 230Vac input
(After warm up 30 minutes).
空載輸入功率 \leq 0.3W.
No-load input power \leq 0.3W

3. 保護功能 (Protection)

3.1 短路電路保護 (Short circuit protection) :

該電源供給器在短路解除時能正常工作恢復。
The power supply will be auto recovered after short circuit faults remove.

3.2 過流保護 (Over current Protection) :

過流故障排除後, 電源將自動恢復正常工作。
The power supply will be auto recovered after over current faults remove.

4. 可靠性要求 (Reliability Requirements)

4.1. 老化 (Burn-in)

產品至少要在 40°C \pm 5°C的環境及 80%額定負載條件下煲機 2-4 小時
The power supply shall be burn-in for 2-4 Hours under normal input and 80% rated load at 40°C \pm 5°C

4.2. 平均間隔故障時間估算 (MTBF Qualification)

平均間隔故障時間: 至少 50,000 小時, 25°C環境及額定輸入與滿載條件下
The MTBF shall be at least 50,000hours at 25°C, Full load and nominal input condition

MODEL NO.:

SK01G-0500100U

DESIGNED NO.:

SK-W2014082307

5. 環境要求 (Environment Requirement)

5.1 工作溫度 (Operating Temperature) :

0°C-40°C, 滿載, 正常工作

0°C to 40°C, Full load, Normal operation.

5.2 儲藏溫度 (Storage Temperature) :

-40°C to 85°C 【帶外殼 (With package)】

5.3 工作濕度 (Relative Humidity) :

5% (0°C) ~95% (40°C) , 72 小時, 滿載, 正常工作.

5% (0°C) ~95% (40°C) RH, 72Hrs, Full load, Normal operating.

5.4 振動 (Vibration) :

5.4.1. 測試標準: 國際電工電子委員會

Operating: IEC 721-3-3 3M3

5~9Hz, A=1.5mm

9~200Hz, 加速度 Acceleration 5m / S2

5.4.2. 運輸 (Transportation) :

IEC 721-3-2 2M2

5-9Hz, A=3.5mm

9~200Hz, 加速度 Acceleration=5m / S2

200~500Hz, 加速度 Acceleration=15m / S2

5.4.3. 軸向振動 (Axes, 10 cycles per axis) :

在測試過程中不能出現永久性的損壞.

No permanent damage may occur during testing.

在電源開啟和關閉後, 樣機能夠恢復到最初條件.

The product can restore to its original situation after power off / on.

5.5 跌落試驗 (Dropping Packed) :

一個角, 三個稜, 六個面.

1 corner, 3 edges, and 6 surfaces

高度 76cm

Height: 76cm.

MODEL NO.:

SK01G-0500100U

DESIGNED NO.:

SK-W2014082307

6. 安全及 EMI 要求 (Safety and EMI Requirement) :

6.1 安全:符合標準 (Safety: accord with):

certificate	國家/Country	standards	
<input type="checkbox"/> UL/CUL	美國/USA	UL60065	
<input checked="" type="checkbox"/> UL/CUL	美國/USA	UL60950	
<input type="checkbox"/> TUV/GS	歐洲/Europe	EN60065	
<input type="checkbox"/> TUV/GS	歐洲/Europe	EN60950	
<input type="checkbox"/> FCC	美國/USA	Class B	
<input type="checkbox"/> CE	歐洲/Europe	EN60065	
<input checked="" type="checkbox"/> CE	歐洲/Europe	EN60950	
<input type="checkbox"/> MEPS	澳洲/Australia	AS/NZS 4665	
<input type="checkbox"/> SAA	澳洲/Australia	AS/NZS 60065	
<input type="checkbox"/> SAA	澳洲/Australia	AS/NZS 60950	
<input type="checkbox"/> CCC	中國/China	GB8898	
<input checked="" type="checkbox"/> CCC	中國/China	GB4943	
<input type="checkbox"/> PSE	日本/Japan	J60950 (H22)	
<input type="checkbox"/> CB	歐洲/Europe	IEC60065	
<input type="checkbox"/> CB	歐洲/Europe	IEC60950	
<input type="checkbox"/> C-TICK	澳洲/Australia	AS/NZS CISPR13:2004	
<input type="checkbox"/> EK/KC	韓國/Korea	K60065	
<input type="checkbox"/> EK/KC	韓國/Korea	K60950	

6.2 EMI 標準 (EMI STANDARD):

Meets the Limits /測試符合

<1>.Fcc class B rules

<2>.EN55022 class B rules

6.3 絕緣強度 (Dielectric Strength Testing):

絕緣強度滿足下表的要求，100% 線上產品執行此項測試，並每一項目至少保持 5 S 時間，無任何故障。

Hi-pot test shall be met the table 5 requirements, an item listing this test as a 100% production test must be performed and be maintained at that level for a minimum of 5 seconds without failure.

項目 (ITEM)	測試規格 (SPECIFICATION)	結果 (REMARK)
輸入 — 輸出 Primary to Secondary	3000Vac/5mA/5s	無飛狐 No arcing
輸入—地 Primary to P.G		無擊穿 No broken
輸出—地 Secondary to P.G		

MODEL NO.:

SK01G-0500100U

DESIGNED NO.:

SK-W2014082307

7. 測試設備清單 (Test Equipment List)

項目	設備名稱	製造	型號
1	變頻電源 (AC power source)	Chroma	6120
2	示波器 (Oscilloscope)	Tektronix	TDS1002B
3	電子負載儀 (Electronic load)	TET	T3515
4	萬用表 (Multimeter)	FLUCK	87 III
5	功率計 (Dynamometer)	Chroma	2100
6	溫度錶 (Thermograph)	LUTRON	TW-902C
7	插頭引線彎折試驗機 (Plug lead bend test machine)	聯欣	LX-817
8	鹽霧試驗機 (Salt spraying tester)	聯欣	LX-8827B
9	震動台 (Vibration table)	精技實驗	FZD-25
10	跌落測試台 (Drop test bed)	自製	
11	數顯卡尺 (Digimatic caliper)	上海量具	0-150mm

8. 結構參數 (MECHANICAL REQUIREMENT) :

8.1 外殼 (Enclosure) :

外殼尺寸: L54.4x W24.0x H33.8mm;

The power supply size: L54.4x W24.0x H33.8mm

8.2 輸入線 (Input Connector) :

2 Pin 插腳

Two pin input plug.

8.3 產品外觀圖片 (Photograph of the product):



MODEL NO.:

SK01G-0500100U

DESIGNED NO.:

SK-W2014082307

9. 機械規格 (MECHANICAL SPECIFICATIONS)

9.1 物理尺寸 (Dimension):

54.4mm X24.0mm X33.8mm (L* W * H , 見圖).

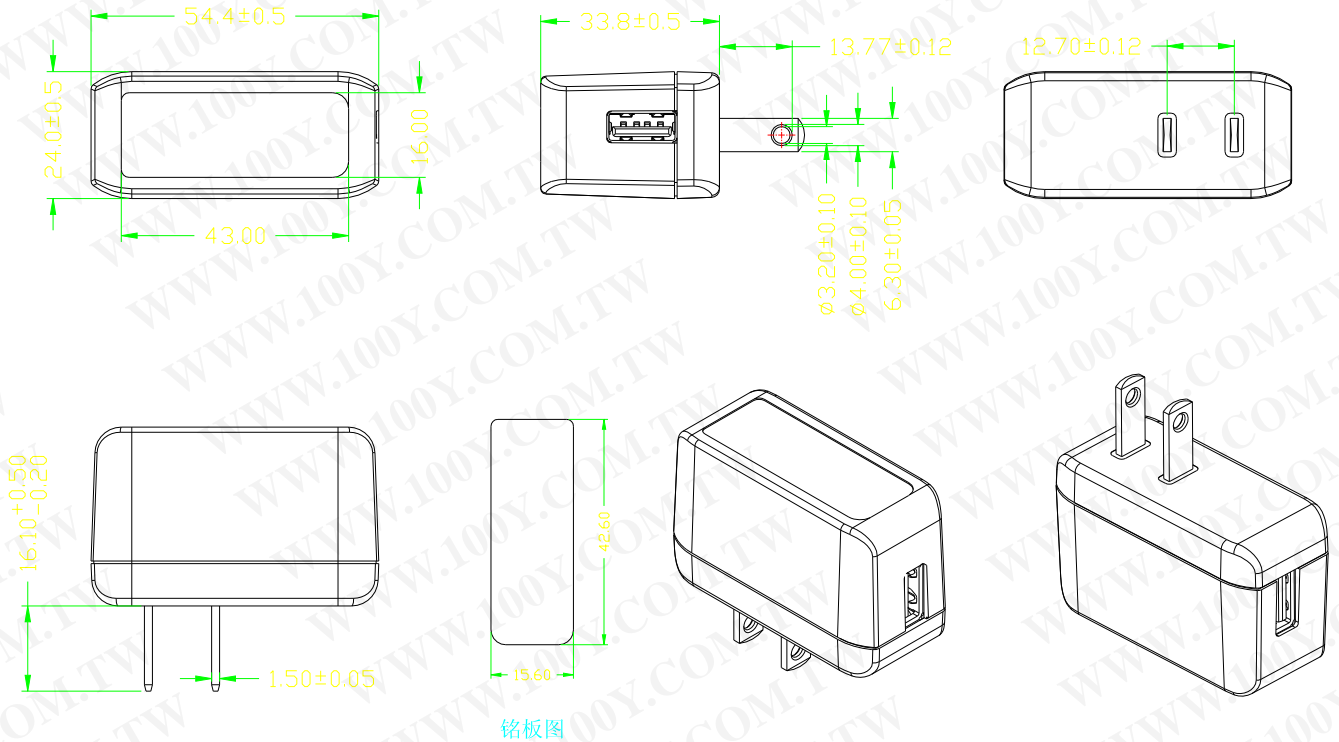

9.2 DC 線尺寸圖 (DC Output Cord Drawing):

(見圖). USB 24A/2464/1.5M USB+MICRO5PIN

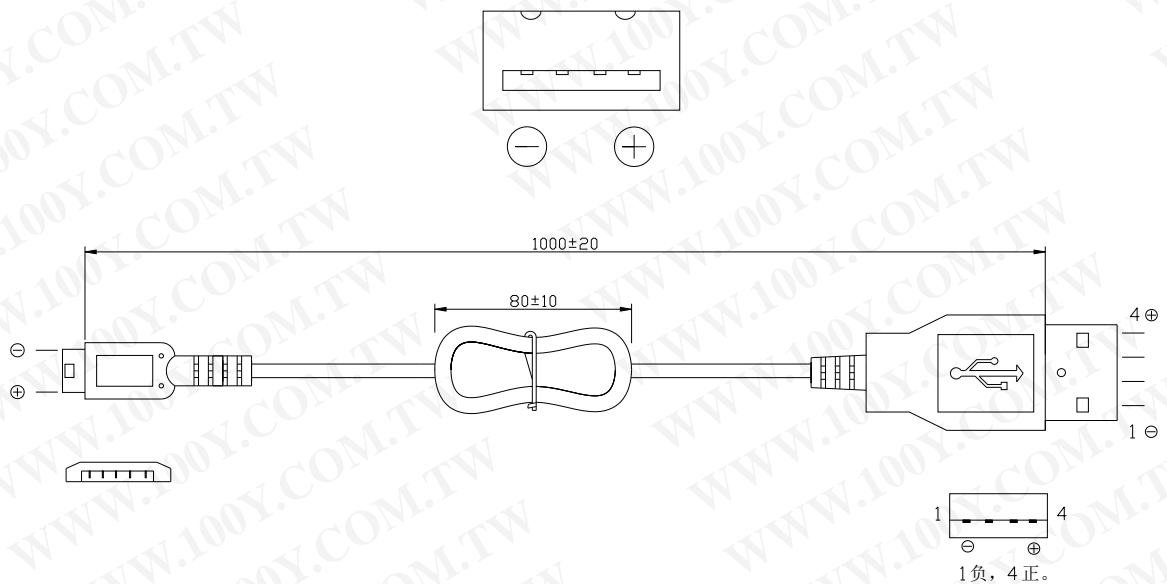

MODEL NO.:

SK01G-0500100U

DESIGNED NO.:

SK-W2014082307

9.3 極性和連接器腳位定義 (Polarity and Pin Connection)

9.3.1. 極性 (Polarity):

1 負 4 正

9.3.2. 連接器腳位定義 (Pin Connection)

1	1	1 負
2	2	短路
3	3	短路
4	4	4 正
5		-

10. 重量 (Weight)

電源的重量大約為 37 g. The weight of the power supply shall be about 37 g.

11. 銘牌圖 (Label Drawing)

銀底黑字 (材質: 啞銀龍) 尺寸 15.6mmX42.6mm

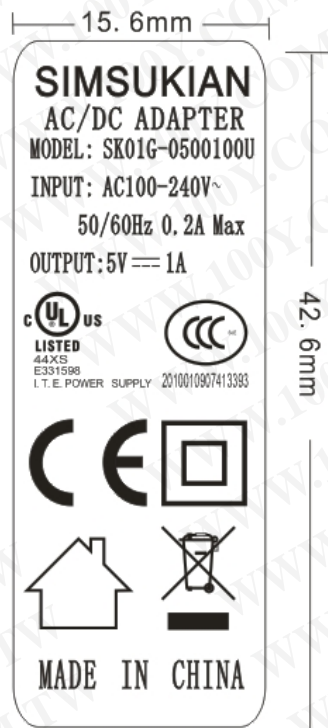

MODEL NO.:

SK01G-0500100U

DESIGNED NO.:

SK-W2014082307

12 包裝圖 (Package Drawing)

200PCS/箱

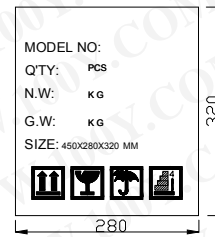
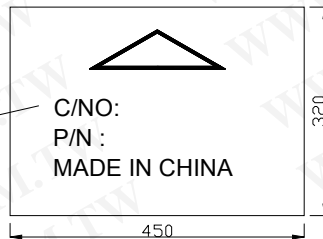
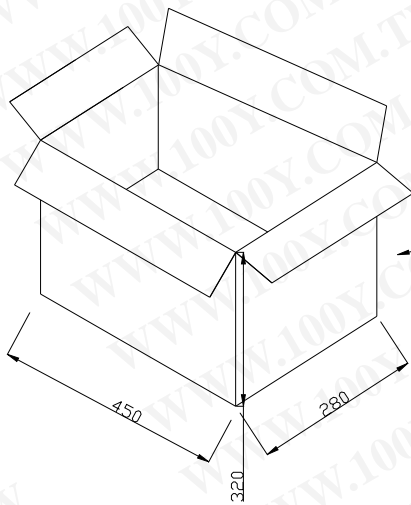

平板:

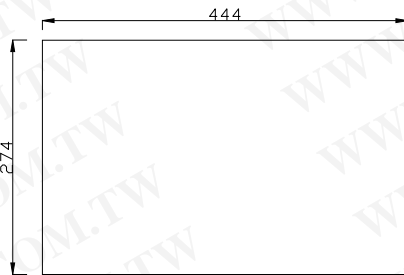

刀卡組合:

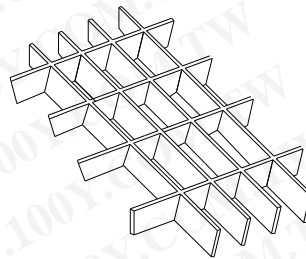

刀卡:

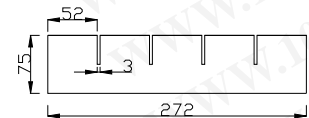
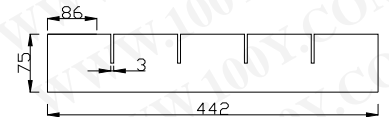

包裝說明 (PACKING):

若客戶未提出包裝方式時，均使用本公司之包裝方式。

Our own packing style will be adopted if no special packing required .

a 內包裝/inner package

PE 袋/PE bag

b 外包裝/ Outer package

紙箱/ paper-box.

尺寸: 450×280×320mm ,5×5刀卡加平板5張274X444mm

c 外包裝箱標識/ Outer package notes include the information

客戶、訂單號、品名、數量、日期等信息

Customer Name, LOT Number, Model No., Date, and so on.

MODEL NO.:

SK01G-0500100U

DESIGNED NO.:

SK-W2014082307