

# QUINT-PS/1AC/24DC/20

Primary-switched power supply  
with SFB technology, 1 AC, output current 20 A

## INTERFACE

### Data Sheet

103129\_en\_01

© PHOENIX CONTACT - 05/2008



## 1 Description

QUINT POWER power supply units – highest system availability due to SFB technology  
Compact power supply units of the new QUINT POWER generation maximize the availability of your system. Even the standard power circuit-breakers can be tripped reliably and quickly with the SFB technology (Selective Fusebreaking Technology) and six times the nominal current for 12 ms. Defective current paths are disconnected selectively, the defect is limited and the important system parts remain in operation. A comprehensive diagnostics is carried out by continuously monitoring the output voltage and current. This preventive function monitoring visualizes the critical operating modes and reports them to the control unit before an error occurs.

- Quick tripping of standard power circuit breakers with dynamic SFB technology power reserve
- Reliable starting of difficult loads with static POWER BOOST power reserve
- Preventive function monitoring
- Can be used worldwide
- High degree of operational safety due to high MTBF > 500 000 h, long mains buffering times > 20 ms, high dielectric strength up to 300 V AC

勝特力材料 886-3-5753170  
勝特力电子(上海) 86-21-34970699  
勝特力电子(深圳) 86-755-83298787  
[Http://www.100y.com.tw](http://www.100y.com.tw)

**2 Table of contents**

1 Description ..... 1

2 Table of contents ..... 2

3 Order data ..... 3

4 Technical data ..... 3

5 Structure ..... 6

6 Block diagram ..... 7

7 Safety and warning notes ..... 7

8 Installation ..... 8

9 Installation position ..... 8

    Slim-style installation ..... 9

    Low-profile installation ..... 9

10 Connection to various network forms ..... 10

11 Input ..... 10

    Protection of the primary side ..... 10

    Recommended backup fuse for mains protection ..... 10

12 Output ..... 11

    Protection of the secondary side ..... 11

13 Signaling ..... 11

    Floating contact ..... 12

    Active signal outputs ..... 12

    Signal loop ..... 12

14 Function ..... 13

    Output characteristic curve ..... 13

    Thermal behavior ..... 13

    Parallel operation ..... 14

    Redundant operation ..... 14

    Increased performance ..... 14

勝特力材料 886-3-5753170  
 勝特力电子(上海) 86-21-34970699  
 勝特力电子(深圳) 86-755-83298787  
[Http://www.100y.com.tw](http://www.100y.com.tw)

### 3 Order data

Description	Type	Order No.	Pcs./Pkt.
Primary-switched power supply with SFB technology, 1 AC, output current 20 A	QUINT-PS/1AC/24DC/20	2866776	1
Accessories	Type	Order No.	Pcs./Pkt.
Assembly adapter for QUINT POWER 2.5 A and 5 A on S7-300 rail	QUINT-PS-ADAPTERS7/1	2938196	1
Universal wall adapter	UWA 182/52	2938235	1

### 4 Technical data

Input data	
Input nominal voltage range	100 V AC ... 240 V AC
AC input voltage range	85 V AC ... 264 V AC
Short-term input voltage	300 V AC
DC input voltage range	90 V DC ... 350 V DC
AC frequency range	45 Hz ... 65 Hz
DC frequency range	0 Hz
Current consumption	Approx. 5.1 A (120 V AC) Approx. 2.3 A (230 V AC)
Inrush current limitation	< 20 A (typical)
$i^2t$	< 3.2 A <sup>2</sup> s
Power failure bypass	> 20 ms (for 120 V AC) > 20 ms (for 230 V AC)
Typical response time	< 0.5 s
Protective circuitry	Transient surge protection Varistor
Input fuse, integrated	12 A (slow-blow, internal)
Recommended backup fuse for mains protection	10 A (characteristic B) 16 A (characteristic B)
Discharge current to PE	< 3.5 mA
Output data	
Nominal output voltage	24 V DC $\pm$ 1%
Setting range of the output voltage	18 V DC ... 29.5 V DC (> 24 V constant capacity)
Output current	20 A (-25°C ... 70°C) 26 A (with POWER BOOST, < 40°C permanent) 120 A (with SFB technology, 12 ms)
Derating	From +60°C 2.5% per Kelvin
Control deviation	< 1 % (change in load, static 10% ... 90%) < 2 % (change in load, dynamic 10% ... 90%) < 0.1 % (change in input voltage $\pm$ 10%)
Power loss nominal load max.	46 W
Maximum power dissipation idling	10 W
Efficiency	> 93 % (for 230 V AC and nominal values)
Ascent time	< 0.5 ms
Residual ripple	< 80 mV <sub>PP</sub> (with nominal values)
Connection in parallel	Yes, for redundancy and increased capacity
Connection in series	Yes
Surge protection against internal surge voltages	Yes, limited to approx. 35 V DC
Resistance to reverse feed	Max. 35 V DC

**Signal output DC OK active**

Output description	$U_{OUT} > 0.9 \times U_N$ : High signal
Voltage	+ 24 V DC
Current	≤ 1 A (short circuit resistant)
Status display	"DC OK" LED green / $U_{OUT} < 0.9 \times U_N$ : LED flashing

**Signal output DC OK floating**

Output description	Relay contact, $U_{OUT} > 0.9 \times U_N$ : Contact closed
Voltage	≤ 30 V AC/DC
Current	≤ 1 A
Status display	"DC OK" LED green / $U_{OUT} < 0.9 \times U_N$ : LED flashing

**Signal output POWER BOOST, active**

Output description	$I_{OUT} < I_N$ : High signal
Voltage	+ 24 V DC
Current	≤ 1 A (short circuit resistant)
Status display	LED "BOOST", yellow / $I_{OUT} > I_N$ : LED on

**General data**

Insulation voltage input/output	4 kV AC (type test) 2 kV AC (routine test)
Insulation voltage input / PE	3.5 kV AC (type test) 2 kV AC (routine test)
Insulation voltage output / PE	500 V DC (routine test)
Degree of protection	IP20
Class of protection	I, with PE connection
MTBF	> 500 000 h in acc. with IEC 61709 (SN 29500)
Housing version	Steel sheet, zinc-plated
Dimensions W / H / D (state of delivery)	90 mm / 130 mm / 125 mm
Dimensions W / H / D (90° turned)	122 mm / 130 mm / 93 mm
Weight	1.7 kg

**Ambient conditions**

Ambient temperature (operation)	-25 °C ... 70 °C (> 60°C derating)
Ambient temperature (storage/transport)	-40 °C ... 85 °C
Max. permissible relative humidity (operation)	95 % (at 25°C, no condensation)
Vibration (operation)	< 15 Hz, amplitude ±2.5 mm in acc. with IEC 60068-2-6 15 Hz ... 150 Hz, 2.3g, 90 min.
Shock	30g in all directions in acc. with IEC 60068-2-27
Pollution degree in acc. with EN 50178	2
Climatic class	3K3 (in acc. with EN 60721)

**Standards**

Electrical Equipment for Machinery	EN 60204
Safety transformers for power supply units	IEC 61558-2-17
Electrical safety (of information technology equipment)	IEC 60950/VDE 0805 (SELV)
Electronic equipment for use in electrical power installations	EN 50178/VDE 0160
SELV	IEC 60950 (SELV) and EN 60204 (PELV)
Safe isolation	DIN VDE 0100-410
Protection against electric shock	DIN 57100-410
Protection against electric shock, basic requirements for safe isolation in electrical equipment	DIN VDE 0106-101

**Standards (Continued)**

Limitation of mains harmonic currents	EN 61000-3-2
Device safety	GS (tested safety)
Network variants (undervoltage)	Semi F47-200
Certificate	CB Scheme

**Approvals**

UL rating	UL Listed UL 508 UL/C-UL Recognized UL 60950
-----------	---

**Conformance with EMC directive 89/336/EEC**

**Immunity to interference in acc. with EN 61000-6-2**

Discharge of static electricity

Housing	Level 4
Contact discharge	8 kV
Discharge in air	15 kV
Comments	Criterion B

Electromagnetic HF field

Housing	Level 4
Frequency range	80 MHz ... 1000 MHz
Field intensity	20 V/m
Comments	Criterion A

Fast transients (burst)

Input	4 kV (level 4 - asymmetrical)
Output	2 kV (level 1 - asymmetrical)
Signal	1 kV (level 1 - asymmetrical)
Comments	Criterion B

Surge current loads (Surge)

Input	4 kV (inst. class 4 - asymmetrical: conductor to ground) 2 kV (inst. class 4 -symmetrical: conductor to conductor)
Output	2 kV (level 3 - asymmetrical: conductor to ground) 1 kV (level 1 - symmetrical: conductor to conductor)
Signal	1 kV (level 3 - asymmetrical: conductor to ground)
Comments	Criterion B

Conducted interference

Input/Output/Signal	Level 3 - asymmetrical
Frequency range	0.15 MHz ... 80 MHz
Voltage	10 V
Comments	Criterion A

Voltage dips

Input	(mains buffering > 20 ms)
Comments	Criterion B

**Emitted interference in acc. with EN 61000-6-3**

Radio interference voltage in acc. with EN 55011	EN 55011 (EN 55022) Class B, area of application: Industry and residential
Emitted radio interference in acc. with EN 55011	EN 55011 (EN 55022) Class B, area of application: Industry and residential

## 5 Structure

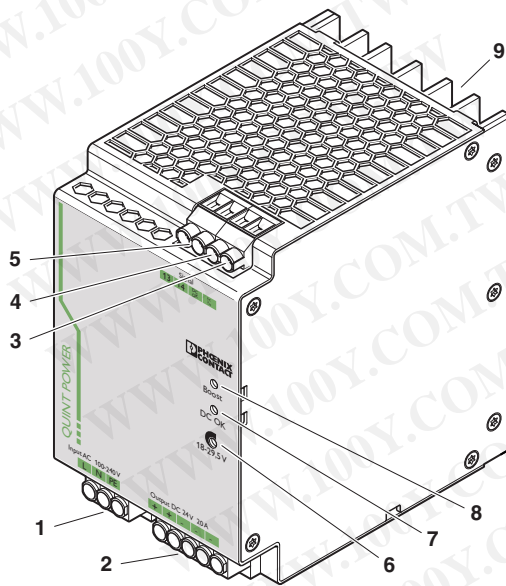

- 1 AC input
- 2 DC output
- 3 Active POWER BOOST switching output
- 4 DC OK output active
- 5 DC OK output, floating
- 6 Potentiometer 18 V DC ... 29.5 V DC
- 7 "DC OK" LED
- 8 "BOOST" LED
- 9 Universal DIN rail adapter UTA 107/30

	[mm <sup>2</sup> ]		AWG	[Nm] Torque
	solid	stranded		
Input	0.2 - 6	0.2 - 4	18 - 10	0.5 - 0.6
Output	0.2 - 6	0.2 - 4	12 - 10	0.5 - 0.6
Signal	0.2 - 6	0.2 - 4	18 - 10	0.5 - 0.6

### Input data

Input nominal voltage range	100 V AC ... 240 V AC
AC input voltage range	85 V AC ... 264 V AC
DC input voltage range	90 V DC ... 350 V DC
AC frequency range	45 Hz ... 65 Hz
DC frequency range	0 Hz
Input fuse, integrated	12 A (slow-blow, internal)
Recommended backup fuse for mains protection	10 A (characteristic B) 16 A (characteristic B)
Type of connection	Screw connection
Stripping length	7 mm

### Output data

Nominal output voltage	24 V DC $\pm$ 1%
Setting range of the output voltage	18 V DC ... 29.5 V DC (> 24 V constant capacity)
Output current	20 A (-25°C ... 70°C) 26 A (with POWER BOOST, < 40°C permanent) 120 A (with SFB technology, 12 ms)
Type of connection	COMBICON screw/plug connection
Stripping length	7 mm

勝特力材料 886-3-5753170  
 勝特力电子(上海) 86-21-34970699  
 勝特力电子(深圳) 86-755-83298787  
[Http://www.100y.com.tw](http://www.100y.com.tw)

## 6 Block diagram

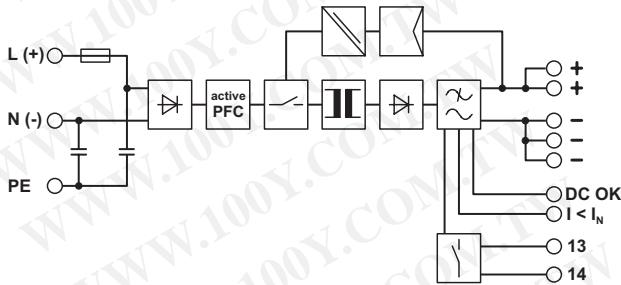

## 7 Safety and warning notes



The power supply units are built-in devices. The device may only be installed and put into operation by qualified personnel. The corresponding national regulations must be observed.



### **DANGER OF EXPLOSION!**

**Remove an item only when it is not connected to power or if it is located in the non-explosive area.**

### **DANGER**

**Components with dangerously high voltage and high stored energy are located in the device!**

**Never carry out work on live parts!**

**Depending on the ambient temperature and the load, the housing can become very hot!**



### **Before startup please ensure:**

**The mains connection has been carried out by a competent person and protection against electric shock is guaranteed!**

**The device can be disconnected outside the power supply unit in accordance with the regulations as in EN 60950 (e.g. through primary side line protection)!**

**The ground conductor is connected!**

**All feed lines are sufficiently protected and dimensioned!**

**All output lines are dimensioned according to the maximum output current of the device or separately protected!**

**Sufficient convection is guaranteed!**

勝特力材料 886-3-5753170  
 勝特力电子(上海) 86-21-34970699  
 勝特力电子(深圳) 86-755-83298787  
[Http://www.100y.com.tw](http://www.100y.com.tw)

## 8 Installation

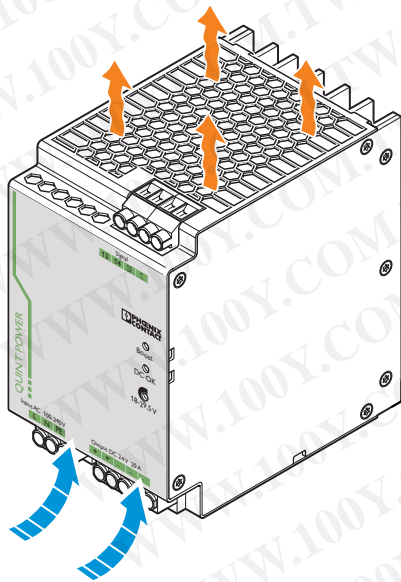

In order to guarantee sufficient convection, we recommend observing the following minimum distance to other modules: 5 cm in the vertical direction and 0.5 cm in the horizontal direction. A lateral distance of 5 mm, and in case of active components, that of 15 mm is necessary for proper functioning of the module. Depending on the ambient temperature and the load of the module, the housing can become very hot!



The power supply unit can be snapped onto all DIN rails in acc. with EN 60715. They must be horizontal (connecting terminal blocks above and below).

## 9 Installation position

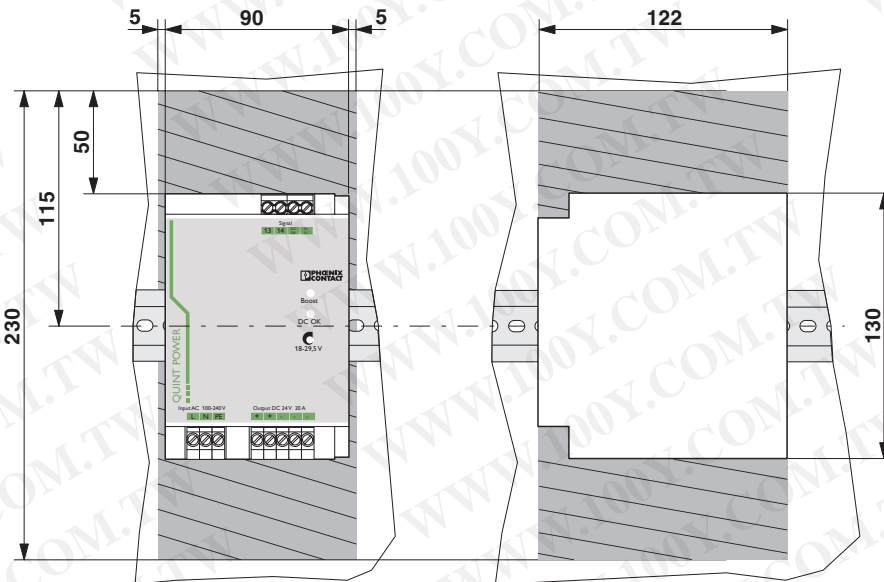

Slim-style installation: Installation depth 125 mm (+ DIN rail)  
(state at delivery)

Low-profile installation: Installation depth 90 mm (+ DIN rail)

勝特力材料 886-3-5753170  
 勝特力电子(上海) 86-21-34970699  
 勝特力电子(深圳) 86-755-83298787  
[Http://www.100y.com.tw](http://www.100y.com.tw)



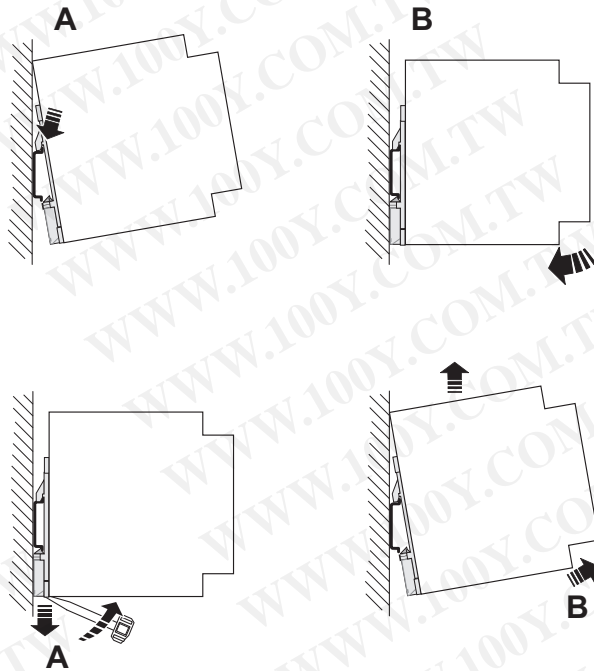

### Slim-style installation

#### Assembly:

Position the module with the DIN rail guide on the upper edge of the DIN rail, and snap it in with a downward motion.

#### Removing:

Pull the snap lever open with the aid of a screwdriver and slide the module out at the lower edge of the DIN rail.

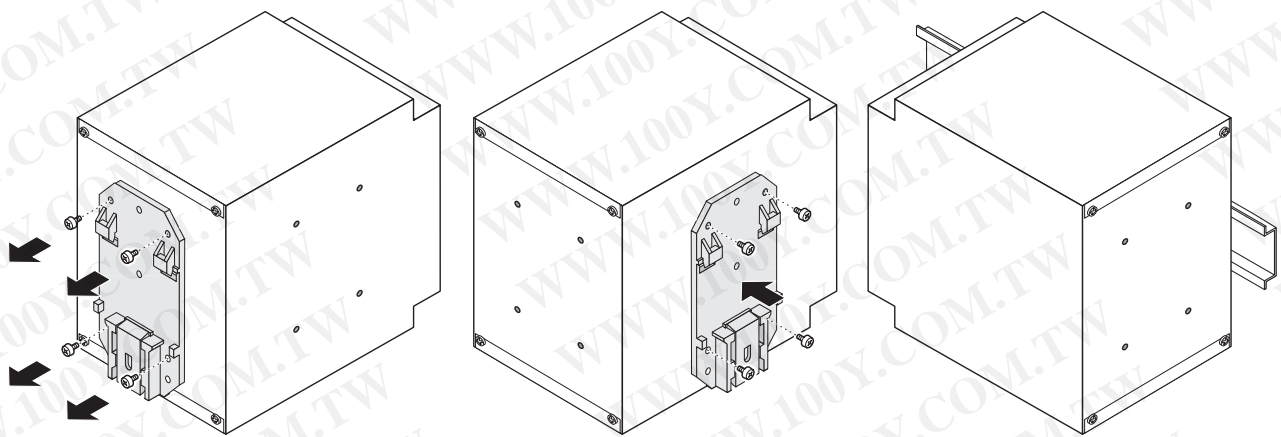

### Low-profile installation

Low-profile installation can be achieved by mounting the device at right-angles to the DIN rail. Mount the DIN rail adapter (UTA 107/30) as described in the figure. No additional mounting material is required. Fixing screws: Torx T10 (torque 0.8 Nm ... 0.9 Nm).

## 10 Connection to various network forms

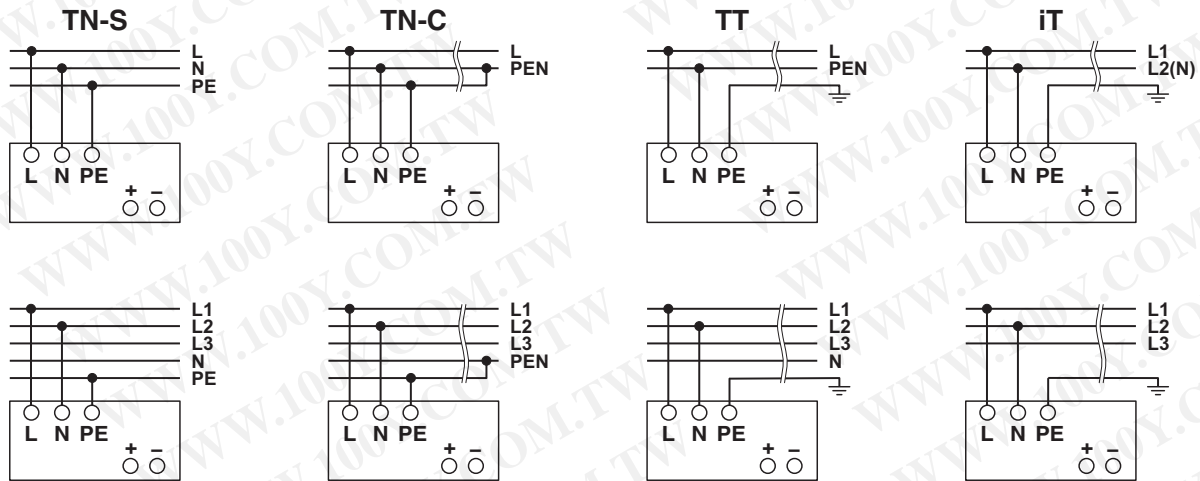

The 100 ... 240 V AC connection is established using the L, N and PE screw connections. The device can be connected to 1-phase AC networks or to two of the phase conductors of three-phase systems (TN, TT or iT systems in acc. with VDE 0100-300/IEC 60364-3) with nominal voltages of 100 V AC ... 240 V AC.



For operation on two of the phase conductors of a three-phase system, an isolating facility for all poles must be provided.

## 11 Input

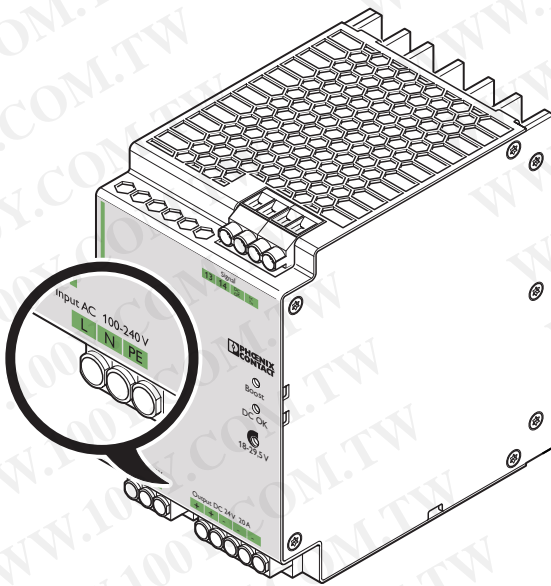

### Protection of the primary side

The device must be installed in acc. with the regulations as in EN 60950. It must be possible to disconnect the device using a suitable isolating facility outside the power supply. The primary side line protection, for example, is suitable. For device protection, there is an internal fuse. Additional device protection is not necessary.

### Recommended backup fuse for mains protection

Power circuit breaker 10 A or 16 A, characteristic B (or identical function). In DC applications, a suitable fuse must be wired in upstream.



**If an internal fuse is triggered, there is most probably a malfunction in the device. In this case, the device must be inspected in the factory!**

## 12 Output

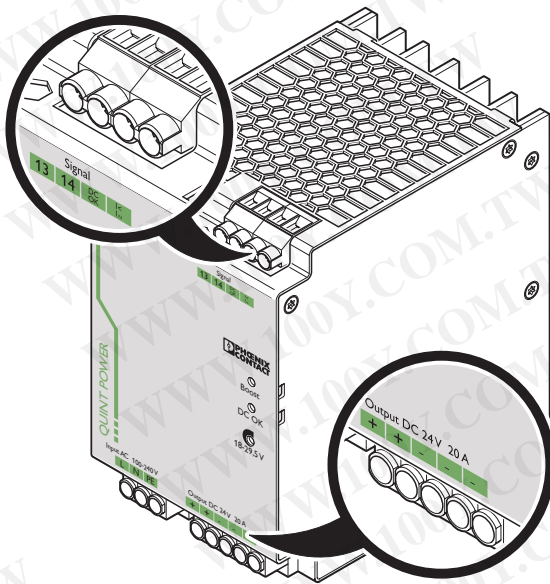

**Make sure that all output lines are dimensioned according to the maximum output current or are separately protected. The cables on the secondary side must have sufficiently large cross sections in order to keep the voltage drops on the lines as low as possible.**

The connection is established using screw connections on the screw connection of the DC output:  
 24 V DC: "+" and "-"; DC OK switching output active: "DC OK" and "-"; DC OK output floating: "13" and "14"; POWER BOOST switching output active: "I < I<sub>N</sub>" and "-".  
 At the time of delivery, the output voltage is 24 V DC. The output voltage can be set on the potentiometer.

### Protection of the secondary side

The device is electronically protected against short circuit and idling. In the event of a malfunction, the output voltage is limited to 35 V DC.

## 13 Signaling

The active signal output, the floating signal contact and the active POWER BOOST switching output are provided for function monitoring. The DC OK-LED and the BOOST-LED also enable the function evaluation of the power supply unit directly on the operation site (refer to the output characteristic curve).

	$I < I_N$	$I > I_N$	$U_{OUT} < 0.9 \times U_N$
"DC OK" LED	ON	ON	Flashing
"BOOST" LED	OFF	ON	ON
Active DC OK switching output	ON	ON	OFF
Floating DC OK output	Closed	Closed	Open
Active POWER BOOST switching output	ON	OFF	OFF
Meaning	Normal operation of the power supply ( $U_{OUT} > 21.5 \text{ V}$ )	POWER BOOST operation, e.g. to start loads	Overload mode, e.g. consumer short circuit or overload

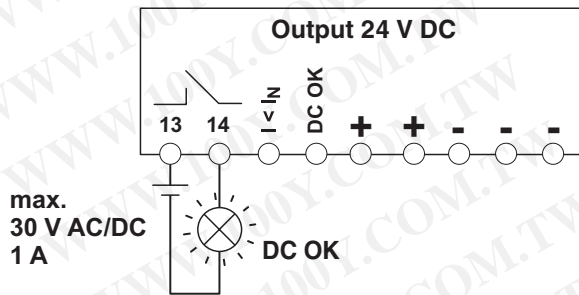

### Floating contact

The floating signal contact opens and signals a drop in the output voltage as set of more than 10%. Signals and ohmic loads of up to 30 V and currents of up to 1 A can be connected. For heavily inductive loads such as a relay, a suitable protection circuit (e.g. damping diode) is necessary.

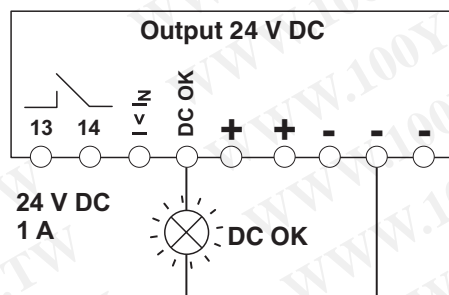

### Active signal outputs

The 24 V DC signal is applied between the "DC OK" and the "-" connecting terminal blocks or between "I < I<sub>N</sub>" and "-" and can carry up to 1 mA. By switching from "active high" to "low", the DC OK signal output signals when the output voltage is more than 10% below the output voltage.

The DC OK signal is decoupled from the power output. It is thus not possible for parallel switched devices to provide external supply.

The 24 V DC signal can be directly connected to a logic input for evaluation.

The POWER BOOST signal output signals that the nominal current is exceeded.

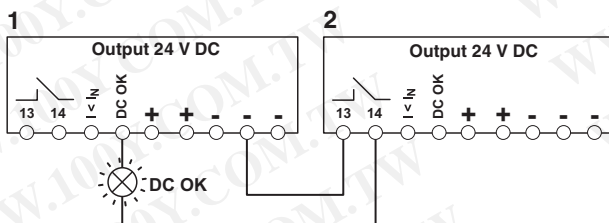

### Signal loop

Monitoring two devices: Use the active signal output of device 1 and loop in the floating signal output of device 2. In the event of malfunctioning, a common alarm is output. Any number of devices can be looped in. This signal combination saves wiring costs and logic inputs.

勝特力材料 886-3-5753170  
 勝特力电子(上海) 86-21-34970699  
 勝特力电子(深圳) 86-755-83298787  
[Http://www.100y.com.tw](http://www.100y.com.tw)

## 14 Function

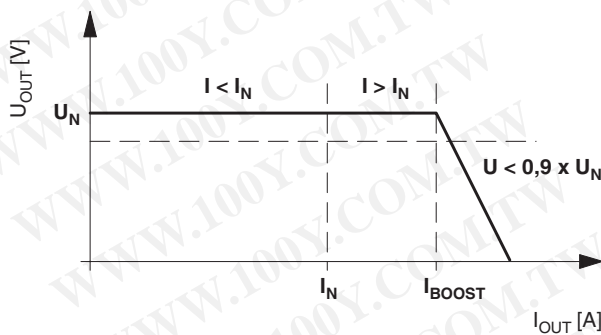

### Output characteristic curve

The power supply unit operates with the static POWER BOOST power reserve as per the U/I characteristic curve given in the figure. In case of ambient temperatures  $T_{amb} < +40^{\circ}\text{C}$ ,  $I_{BOOST}$  is available permanently; it is available only for a few minutes in case of higher temperatures. In the event of a secondary short circuit and overload, the output current is limited to  $I_{BOOST}$ . Thereby, the module does not switch off, but supplies a continuous output current. The secondary voltage is reduced until the short circuit has been remedied. The U/I characteristic curve with the POWER BOOST power reserve ensures that high inrush currents of capacitive loads and of consumers with DC/DC converters in the input circuit can be fed reliably.

In order to trip the standard power circuit breakers magnetically and thus very quickly, QUINT POWER supplies six times the nominal current for 12 ms with the help of the SFB technology. The defective current path is switched off using this dynamic power reserve; consumers connected in parallel continue to operate without an interruption. The error is thus restricted and the important system parts continue to operate.

The characteristic curve shows when  $I < I_N$ ,  $I > I_N$  and  $U < 0.9 \times U_N$ . The relevant signaling is given in the table.

$$U_N = 24 \text{ V}$$

$$I_N = 20 \text{ A}$$

$$I_{BOOST} = 26 \text{ A}$$

$$\text{SFB technology} = 120 \text{ A}$$

$$P_N = 480 \text{ W}$$

$$P_{BOOST} = 625 \text{ W}$$

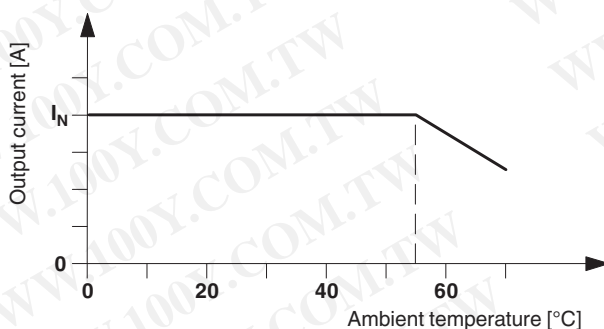

### Thermal behavior

With an ambient temperature of up to  $+40^{\circ}\text{C}$ , the device supplies the continuous output current of  $I_{BOOST}$ . The device can supply a nominal output current of  $I_N$  with ambient temperatures of up to  $+60^{\circ}\text{C}$ . In the case of ambient temperatures above  $+60^{\circ}\text{C}$ , the output current must be reduced by 2.5% per Kelvin increase in temperature. The device does not switch off at ambient temperatures of  $+70^{\circ}\text{C}$  or thermal overload. The output capacity is reduced as far as necessary to provide device protection. After it has cooled down, the output capacity is increased again.