

PROXXON 28759 Tungsten Carbide Millers

超硬鋼銑刀

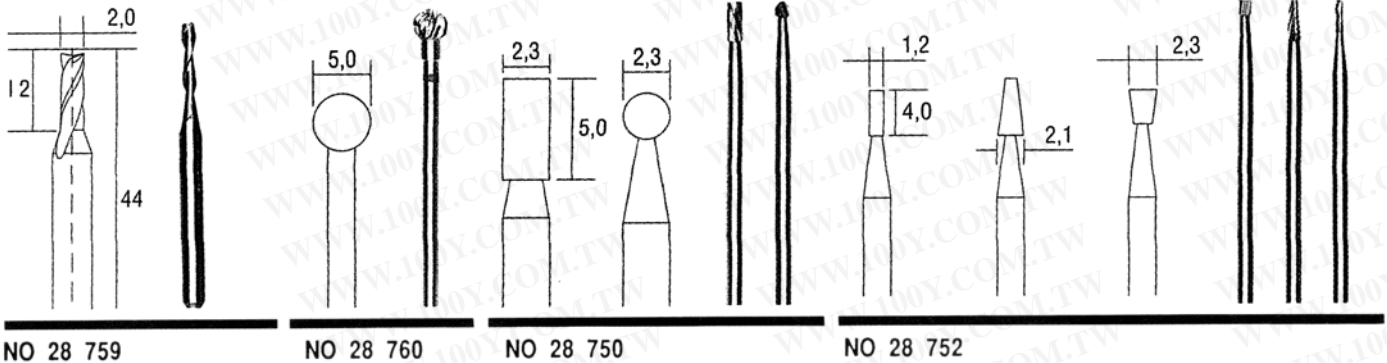

勝特力材料 886-3-5753170
 勝特力电子(上海) 86-21-54151736
 勝特力电子(深圳) 86-755-83298787
[Http://www.100y.com.tw](http://www.100y.com.tw)



NO 28 759
超硬鋼銑刀

NO 28 760

NO 28 750

NO 28 752

不易磨損之硬鋼材質，銑製時不會振動。適用於鋼鐵、鑄鋼、銅鋁、塑膠及其它硬材質。
 亦可用於PC板之銑槽切斷用。柄徑：Ø 2.35mm

Tungsten Carbide Millers

Made of wear-resistant tungsten. Used for vibration-free milling of high accuracy dimensions. it is advisable to secure workpieces well, avoiding accidents. For technical work on extremely hard materials: chrome-cobalt alloy, steel, non-ferrous metals, plastics. May be used for engraving and milling of PC cards.