

AC SOLID STATE RELAY

K3P40C25AA K3P40C75AA
K3P40C40AA K3P40C90AA
K3P40C50AA K3P40C100AA

(HEATER LOAD ONLY)
3PHASE SERIES



勝特力材料 886-3-5753170
 勝特力电子(上海) 86-21-34970699
 勝特力电子(深圳) 86-755-83298787
[Http://www.100y.com.tw](http://www.100y.com.tw)

SPECIFICATIONS

MODEL NO.	CONTROL VOLTAGE RANGE	MUST TURN OFF VOLTAGE	INPUT IMPEDANCE	MAX LOAD CURRENT	LOAD VOLTAGE RANGE	MIN BLOCKING VOLTAGE	MAX OFF-STATE LEAKAGE	FREQUENCY RANGE	MAX 1-CYCLE PEAK SURGE
K3P40C25AA	80~280VAC	MAX 9.5 VDC	1.5Kohm	2.5 A	48-480VAC	1200VAC	LESS 10 mA	47-63HZ	31.5 A
K3P40C40AA	80~280VAC	MAX 9.5 VDC	1.5Kohm	4.0 A	48-480VAC	1200VAC	LESS 10 mA	47-63HZ	45.0 A
K3P40C50AA	80~280VAC	MAX 9.5 VDC	1.5Kohm	5.0 A	48-480VAC	1200VAC	LESS 10 mA	47-63HZ	56.0 A
K3P40C75AA	80~280VAC	MAX 9.5 VDC	1.5Kohm	7.5 A	48-480VAC	1200VAC	LESS 10 mA	47-63HZ	75.0 A
K3P40C90AA	80~280VAC	MAX 9.5 VDC	1.5Kohm	9.0 A	48-480VAC	1200VAC	LESS 10 mA	47-63HZ	90.0 A
K3P40C100AA	80~280VAC	MAX 9.5 VDC	1.5Kohm	100A	48-480VAC	1200VAC	LESS 10 mA	47-63HZ	1030A

MODEL NO.	MAX OFF STATE dv/dt	MAX ON-STATE VOLTAGE DROP	ISOLATE IMPEDENCE	DIELECTRIC STRENGTH INPUT-OUTPUT	DIELECTRIC STRENGTH INPUT-OUTPUT-CASE	TURN ON TIME	TURN OFF TIME	CAPACITANCE IN-OUT	WEIGHT (g)
K3P40C25AA	500V/ μ SEC	1.6Vrms	10^9 ohm	2500Vrms	2500Vrms	LESS1/2mSee	LESS1/2cycle	LESS473pf	600 g
K3P40C40AA	500V/ μ SEC	1.6Vrms	10^9 ohm	2500Vrms	2500Vrms	LESS1/2mSee	LESS1/2cycle	LESS473pf	600 g
K3P40C50AA	500V/ μ SEC	1.6Vrms	10^9 ohm	2500Vrms	2500Vrms	LESS1/2mSee	LESS1/2cycle	LESS473pf	600 g
K3P40C75AA	500V/ μ SEC	1.6Vrms	10^9 ohm	2500Vrms	2500Vrms	LESS1/2mSee	LESS1/2cycle	LESS473pf	600 g
K3P40C90AA	500V/ μ SEC	1.6Vrms	10^9 ohm	2500Vrms	2500Vrms	LESS1/2mSee	LESS1/2cycle	LESS473pf	600 g
K3P40C100AA	500V/ μ SEC	1.6Vrms	10^9 ohm	2500Vrms	2500Vrms	LESS1/2mSee	LESS1/2cycle	LESS473pf	600 g

OUTLINE DIMENSIONS (unit:mm)

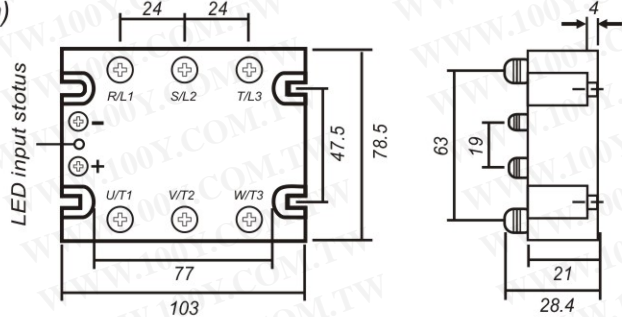

EQUIVALENT CIRCUIT

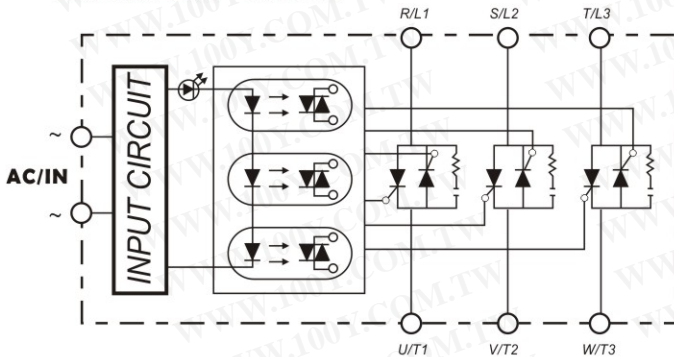

Example of 3 Φ SSR Application

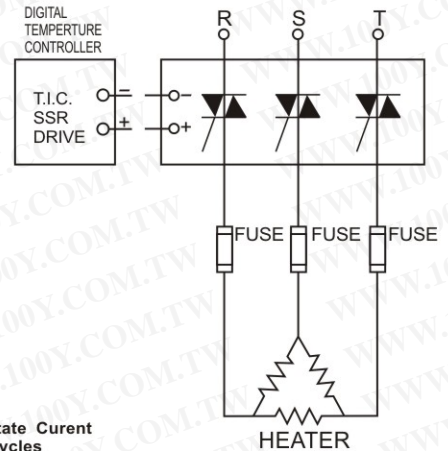

CHARACTERISTIC CURVES

Characteristics curve

RMS On-state Current Versus Case Temperature

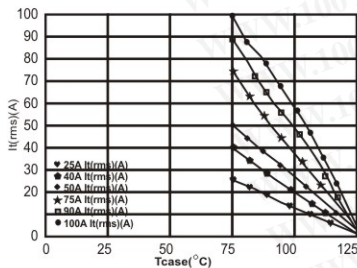

Non Repetitive Surge On-state Current Versus Number Of Cycles

