

DIMENSIONS (mm)

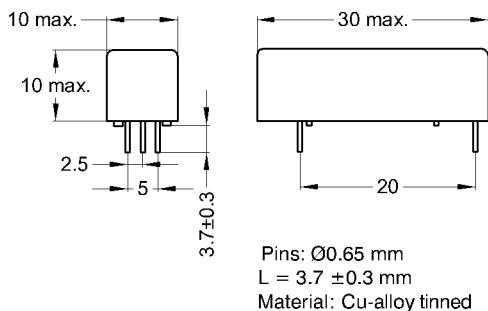

LAYOUT  
 pitch 2.5 mm/Top view

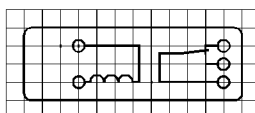

MARKING



MEDER-Label  
 Type/Layout  
 Production code,  
 EN60062/Factory code  
 PTB 01 ATEX 2050U  
 0344 II(1)G [EEx ia] IIC

tolerances according to DIN ISO 2768 m

Coil Data at 20 °C	Conditions	Min	Typ	Max	Unit
Coil resistance		1.170	1.300	1.430	Ohm
Inductance			305		mH
Coil voltage			12		VDC
Rated power			110		mW
Thermal resistance	max. Relay temperature = operating temperature + self heating		85		K/W
Pull-In voltage				9	VDC
Drop-Out voltage		2			VDC

Special Product Data	Conditions	Min	Typ	Max	Unit
Contact rating	Any DC combination of V & A not to exceed their individual max.'s			7	W
Switching voltage	DC or Peak AC			28	V
Switching current	DC or Peak AC			0,24	A
Carry current	DC or Peak AC			0,5	A
Contact resistance static	Measured with 40% overdrive Start Value			150	mOhm
Insulation resistance	RH <45 %, 200 V test voltage	1			GOhm
Breakdown voltage		250			VDC
Operate time incl. bounce	measured with 40% overdrive			2	ms
Release time	measured with no coil excitation			2	ms
Capacitance	@ 10 kHz across open switch		1		pF

Environmental data	Conditions	Min	Typ	Max	Unit
Insulation resistance Coil/Contact	RH <45%, 200 VDC test voltage	1.000			GOhm
Insulation voltage Coil/Contact	according to IEC 255-5	2,5			kV AC
Shock	1/2 sine wave duration 11ms			50	g
Vibration	from 10 - 2000 Hz			20	g
Ambient temperature		-20		85	°C
Storage temperature		-40		105	°C
Soldering temperature	wave soldering max. 5 sec.			260	°C
Cleaning				fully sealed	
Housing material				Plastics / Polyamid	
Sealing compound				Polyurethan	
Connection pins				Copper alloy tin plated	
Remarks				Reed-Relay to be used for the galvanic separation	
Remarks 1.				of intrinsically safe and non-intrinsically safe	
Remarks 2.				circuits with Ex-approval by PTB 01 ATEX 2050 U.	

# Mouser Electronics

Authorized Distributor

Click to View Pricing, Inventory, Delivery & Lifecycle Information:

[Standex Electronics:](#)

[MRX12-1C90](#)