

# NAIS

## SLIM TYPE POWER RELAYS

# JR-RELAYS

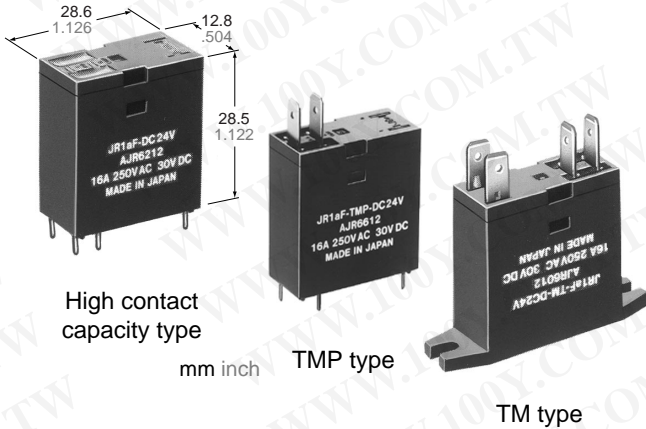

### FEATURES

- AC coil types and high capacity (16 A) types
- Wide insulation distance: 8 mm .315 inch between coil and contact
- High dielectric withstanding for transient protection: JR can withstand 10,000 V surge in  $\mu$ s between coil and contact.
- High inrush current capability: 1 Form A: 111 A inrush (TV-5),
- Slim package for tandem mounting: Header area is 28.6 mm  $\times$  12.8 mm 1.126 $\times$ .504 inch
- Molded materials: all 94 V-0
- "TM" and "TMP" types available
- TÜV also approved

### SPECIFICATIONS

#### Contact

		AC coil type	High capacity type
Arrangement		1 Form A	
Initial contact resistance max. (By voltage drop 6 V DC 1 A)		30 m $\Omega$	
Contact material		Silver alloy	
Rating (resistive)	Nominal switching capacity	10 A 250 V AC 10 A 30 V DC	16 A 250 V AC 16 A 30 V DC
	Maximum switching power	2,500 VA, 300 W	4,000 VA, 480 W
	Maximum switching voltage	250 V AC, 30 V DC	250 V AC, 30 V DC
	Maximum switching current	10 A	16 A
Expected life (min. operations)	Mechanical (180 cpm)	5 $\times$ 10 <sup>6</sup>	
	Electrical (resistive) (20 cpm)	16 A 250 V AC	10 <sup>5</sup>
		10 A 250 V AC	10 <sup>5</sup>

#### Coil

	1.1 VA/0.9 VA (at 50Hz/60Hz)	530mW
Nominal operating power		

#### Remarks

- \* Specifications will vary with foreign standards certification ratings.
- \*1 Detection current: 10mA
- \*2 Wave is standard shock voltage of  $\pm 1.2 \times 50\mu$ s according to JEC-212-1981
- \*3 With nominal coil voltage and at maximum switching current
- \*4 Half-wave pulse of sine wave: 11ms; detection time: 10 $\mu$ s
- \*5 Half-wave pulse of sine wave: 6ms
- \*6 Detection time: 10 $\mu$ s
- \*7 Refer to 5. Conditions for operation, transport and storage mentioned in AMBIENT ENVIRONMENT (Page 24).

#### Characteristics

		AC coil type	High capacity type
Maximum operating speed		20 cpm	
Initial insulation resistance		Min. 1,000 M $\Omega$ at 500 V DC	
Initial breakdown voltage*1	Between open contacts	1,000 Vrms for 1 min.	
	Between contacts and coil	5,000 Vrms for 1 min.	
Initial surge voltage between coil and contact*2		Min. 10,000 V	
Operate time (at nominal voltage)(at 20°C)		Approx. 10 ms	
Release time (without diode) (at nominal voltage)(at 20°C)		Approx. 6 ms	Approx. 2 ms
Temperature rise*3 (at nominal voltage)		Max. 60°C (10 A, at 20°C)	Max. 45°C (16 A, at 20°C)
Shock resistance	Functional*4	Min. 98 m/s <sup>2</sup> {10 G}	
	Destructive*5	Min. 980 m/s <sup>2</sup> {100 G}	
Vibration resistance	Functional*6	88.2 m/s <sup>2</sup> {9 G}, 10 to 55 Hz at double amplitude of 1.5 mm	
	Destructive	117.6 m/s <sup>2</sup> {12 G}, 10 to 55 Hz at double amplitude of 2.0 mm	
Conditions for operation, transport and storage*7 (Not freezing and condensing at low temperature)	Ambient temp.	-50°C to +55°C -58°F to +131°F	-50°C to +70°C -58°F to +158°F
	Humidity	5 to 85% R.H.	
Unit weight		Approx. 20 g .71 oz	

### TYPICAL APPLICATIONS ORDERING INFORMATION

- Microwave ovens
- Refrigerators
- Copiers
- Facsimiles
- Air conditioners
- Stereo equipment
- TV sets
- Vending machines
- Temperature controllers

Ex. JR 1a — TM — DC12V

Contact arrangement	Mounting method	Coil voltage
1a: 1 Form A	TM: Top mounting	AC 115 V
1aF: High contact capacity (1 Form A)	Nil: PCB terminal TM: Top mounting TMP: Solder and PC terminal	DC 5, 6, 12, 24, 48 V

- Notes: 1. For UL/CSA recognized types, add suffix UL/CSA.  
 2. Standard packing: Carton: 100 pcs. Case: 500 pcs.  
 3. 18 V DC type are also available. Please consult us for details.

## TYPES

### High contact capacity types

#### 1. PC board terminals (Double terminal layout)

Contact arrangement	Coil voltage	Part No.
1a	5 V DC	JR1aF-DC5V
	6 V DC	JR1aF-DC6V
	12 V DC	JR1aF-DC12V
	24 V DC	JR1aF-DC24V
	48 V DC	JR1aF-DC48V

#### 2. "TMP" type

Contact arrangement	Coil voltage	Part No.
1a	5 V DC	JR1aF-TMP-DC5V
	6 V DC	JR1aF-TMP-DC6V
	12 V DC	JR1aF-TMP-DC12V
	24 V DC	JR1aF-TMP-DC24V
	48 V DC	JR1aF-TMP-DC48V

#### 3. "TM" type

Contact arrangement	Coil voltage	Part No.
1a	5 V DC	JR1aF-TM-DC5V
	6 V DC	JR1aF-TM-DC6V
	12 V DC	JR1aF-TM-DC12V
	24 V DC	JR1aF-TM-DC24V
	48 V DC	JR1aF-TM-DC48V

### AC coil type

1a	115 V AC	JR1a-TM-AC115V
----	----------	----------------

(Notes) 1. For UL/CSA recognized types, add suffix UL/CSA.  
2. Standard packing Carton: 100 pcs., Case 500 pcs.

### UL CSA TV rating types available

Type	UL	CSA
JR1a AC coil type	TV-5	TV-5
JR1aF high capacity type	TV-5	TV-5

## COIL DATA (at 20°C 68°F)

Contact arrangement	Nominal voltage	Pick-up voltage, (max.) (Initial)	Drop-out voltage, (min.) (Initial)	Coil resistance, Ω (±10%)	Nominal operating current, mA (±10%)	Nominal operating power, mW	Maximum allowable voltage, (at 70°C 158°F)
1 Form A	5 V DC	4.0 V DC	0.5 V DC	47	106	530	5.5 V DC
	6 V DC	4.8 V DC	0.6 V DC	68	88	530	6.6 V DC
	12 V DC	9.6 V DC	1.2 V DC	270	44	530	13.2 V DC
	24 V DC	19.2 V DC	2.4 V DC	1,100	22	530	26.4 V DC
	48 V DC	38.4 V DC	4.8 V DC	4,350	11	530	52.8 V DC
	*115 V AC	92 V AC	34.5 V AC	—	7.8/9.1 (60 Hz)/(50 Hz)	0.9/1.1 VA (60 Hz)/(50 Hz)	126.5V AC (at 20°C 68°F)

Note: Coil resistance varies ±10% for less than 1,000 Ω coil and ±15% for more than 1,000 Ω.  
For each ±1°C change in ambient temperature, coil resistance varies ±0.4%.  
\*AC 100 V coil is available only for JR1a-TM type.

## DIMENSIONS

### • JR1aF (DC)

mm inch

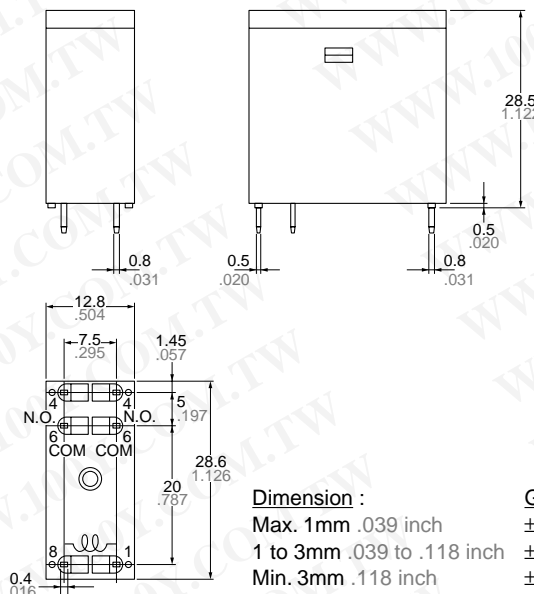

### PC board pattern (Copper-side view)

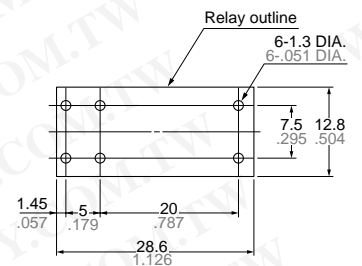

Tolerance: ±0.1 ±.004

### Schematic (BOTTOM VIEW)

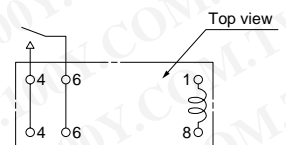

#### Dimension :

Max. 1mm .039 inch  
1 to 3mm .039 to .118 inch  
Min. 3mm .118 inch

#### General tolerance

±0.1 ±.004  
±0.2 ±.008  
±0.3 ±.012

• JR1aF-TMP (DC)

mm inch

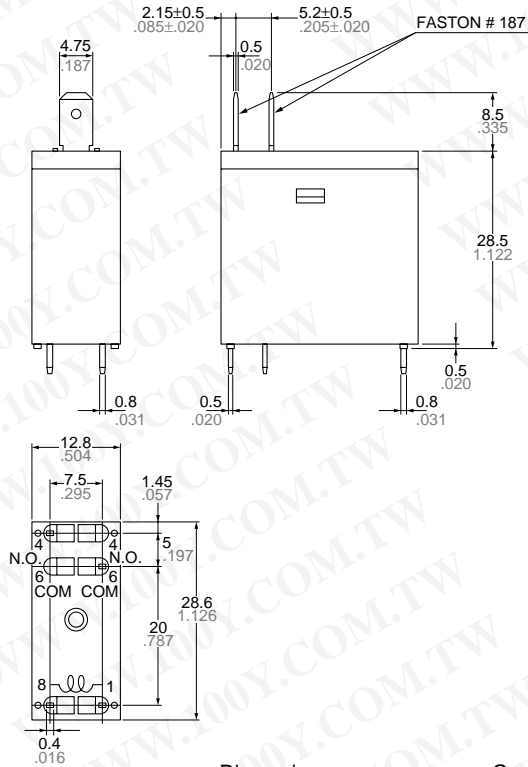

PC board pattern (Copper-side view)

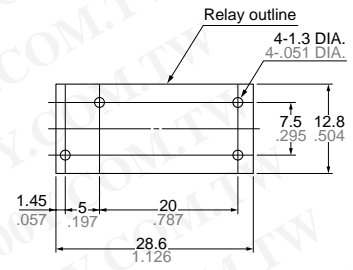

Tolerance: ±0.1 ±.004

Schematic (BOTTOM VIEW)

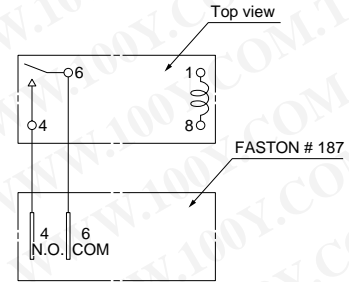

Dimension :	General tolerance
Max. 1mm .039 inch	±0.1 ±.004
1 to 3mm .039 to .118 inch	±0.2 ±.008
Min. 3mm .118 inch	±0.3 ±.012

• JR1aF-TM (DC) / JR1a-TM (AC)

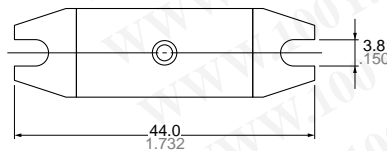

Panel cutout

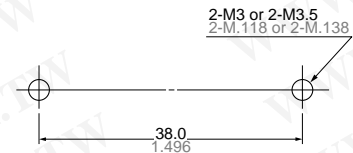

Schematic (BOTTOM VIEW)

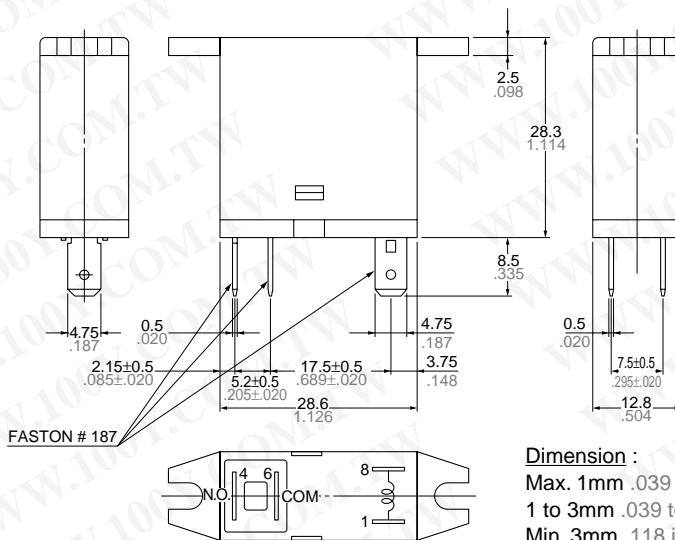
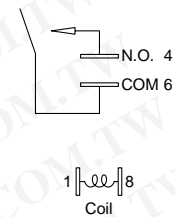

Dimension :	General tolerance
Max. 1mm .039 inch	±0.1 ±.004
1 to 3mm .039 to .118 inch	±0.2 ±.008
Min. 3mm .118 inch	±0.3 ±.012

\* JR1a-TM-AC 100 V is not high contact capacity version but has the same dimensions as JR1aF-TM.

## REFERENCE DATA

### 1. Coil temperature rise

Sample: JR1aF-TM-DC24V

Measurement at coil inside and contact portion

Ambient temperature: 22°C to 25°C 72°F to 77°F

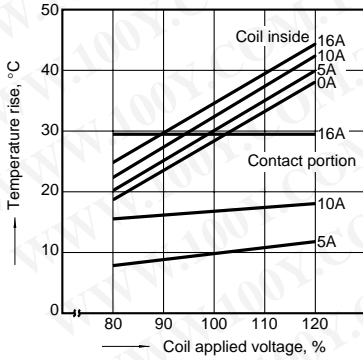

### 2. Operate & release time

Sample: JR1aF-TM-DC24V

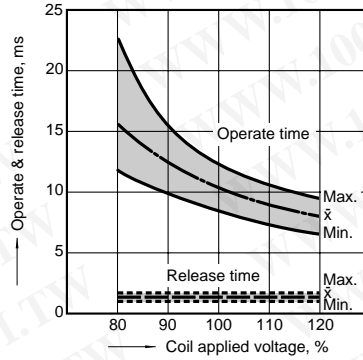

## NOTES

"TM" and "TMP" types of high contact capacity types:

When the contact carrying current exceeds 10 A, the soldering connection at terminals is recommended.

**For Cautions for Use, see Relay Technical Information (Page 11 to 39).**