

Solid State Relays for Industrial I/O

G3TC

Reliable SSRs for I/O Module Mounting Boards

- Use I/O SSRs as an interface between logic circuitry and the load.
- Variety of AC/DC input and output modules with industry-standard footprint and color coding.
- Built-in hold down screw fastens relay to board to eliminate loosening by vibration.
- Optical Isolation - Dielectric strength of 4 kV between input and output terminals.
- Zero cross function on AC output models.
- AC and DC input versions incorporate a rectifier to accept both AC or DC inputs.
- UL, CSA and TUV approved; marked with CE.



Ordering Information

Input Module

Function	Color	Isolation	Input operating voltage range	Logic level output supply voltage	Model
AC input	Yellow	Photo-coupler	90-140 VDC/AC	5 VDC	G3TC-IAC5 AC/DC120
				15 VDC	G3TC-IAC15 AC/DC120
				24 VDC	G3TC-IAC24 AC/DC120
			180-280 VDC/AC	5 VDC	G3TC-IAC5A AC/DC240
				15 VDC	G3TC-IAC15A AC/DC240
				24 VDC	G3TC-IAC24A AC/DC240
DC input	White		10-32 VDC/AC	5 VDC	G3TC-IDC5 DC/AC24
				15 VDC	G3TC-IDC15 DC/AC24
				24 VDC	G3TC-IDC24 DC/AC24

Output Module

Function	Color	Isolation	Rated input voltage	Rated output voltage (Applicable output voltage)	Model
AC output	Black	Photo-triac	5 VDC	3 A at 120 VAC (3 A at 75-140 VAC)	G3TC-OAC5 DC5
			15 VDC		G3TC-OAC15 DC15
			24 VDC		G3TC-OAC24 DC24
			5 VDC	3 A at 240 VAC (3 A at 75-280 VAC)	G3TC-OAC5A DC5
			15 VDC		G3TC-OAC15A DC15
			24 VDC		G3TC-OAC24A DC24
DC output	Red	Photo-coupler	5 VDC	3 A at 60 VDC (3 A at 5-60 VDC)	G3TC-ODC5 DC5
			15 VDC		G3TC-ODC15 DC15
			24 VDC		G3TC-ODC24 DC24
			5 VDC	1 A at 200 VDC (1 A at 5-200 VDC)	G3TC-ODC5A DC5
			15 VDC		G3TC-ODC15A DC15
			24 VDC		G3TC-ODC24A DC24

勝特力材料 886-3-5753170
 勝特力电子(上海) 86-21-34970699
 勝特力电子(深圳) 86-755-83298787
[Http://www.100y.com.tw](http://www.100y.com.tw)

Typical Applications

- HVAC, refrigeration equipment
- Automation controls
- Injection molding machines
- Packaging equipment

I/O Classification by Color

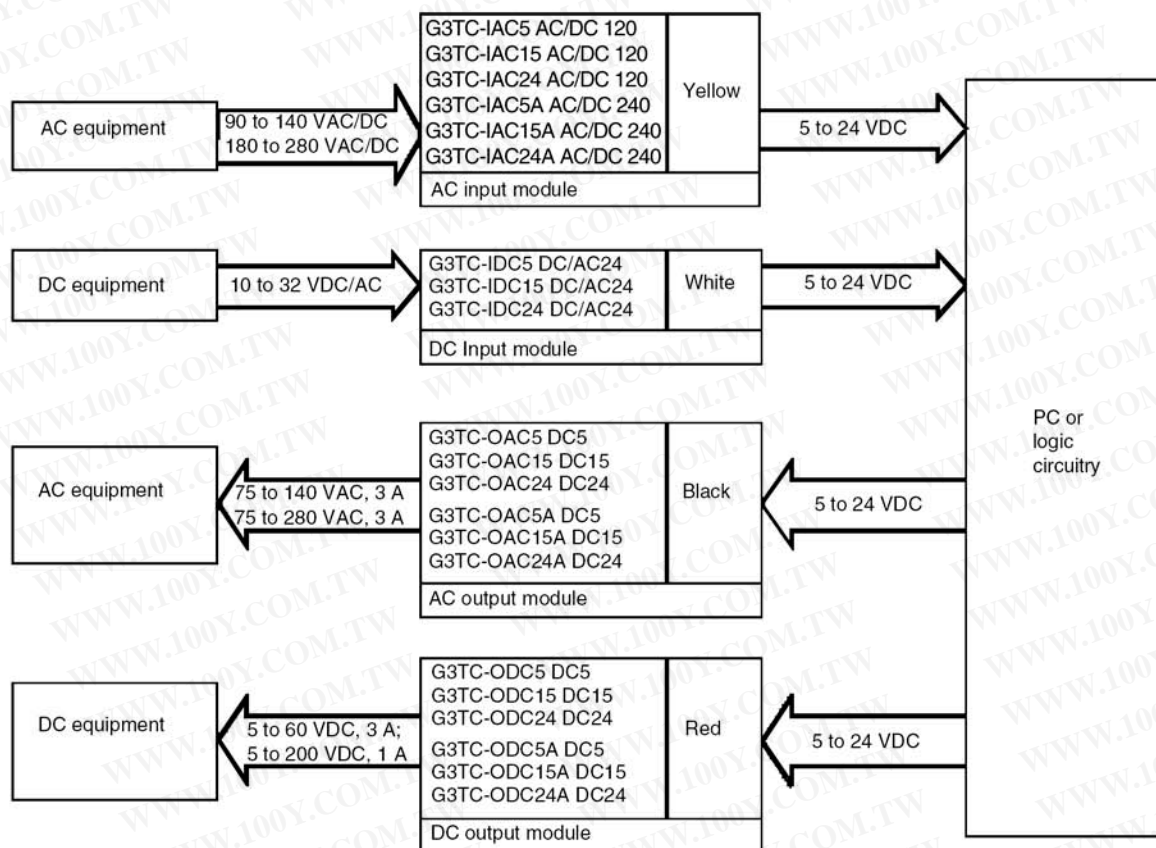

Specifications

Common Characteristics

Insulation resistance	100 MΩ min at 500 VDC
Dielectric strength	4000 VAC, 50/60 Hz for 1 minute between input and output
Vibration resistance	Malfunction: 10 to 55 Hz, 1.5 mm double amplitude
Shock resistance	Malfunction: 1,000 m/s ²
Ambient temperature	Operating: -30°C to 80°C with no icing or condensation Storage: -30°C to 100°C with no icing or condensation
Ambient humidity	Operating: 45% to 85%
Approved standards	UL Recognized, CSA Certified, EN60950

■ AC Input Module G3TC-IAC

Ratings (Ambient Temperature 25°C)

Input

Item	G3TC-IAC5	G3TC-IAC15	G3TC-IAC24	G3TC-IAC5A	G3TC-IAC15A	G3TC-IAC24A
Rated voltage	120 VAC/DC			240 VAC/DC		
Operating voltage	90-140 VAC/DC			180-280 VAC/DC		
Must operate voltage	90 VAC/DC max.			180 VAC/DC max.		
Must release voltage	25 VAC/DC min.			45 VAC/DC min.		
Input current at rated voltage	5 mA max.			5 mA max.		
Input resistance (see note 1)	30 k Ω			69 k Ω		

Output

Item	G3TC-IAC5	G3TC-IAC15	G3TC-IAC24	G3TC-IAC5A	G3TC-IAC15A	G3TC-IAC24A
Output supply voltage-nominal	5 VDC	15 VDC	24 VDC	5 VDC	15 VDC	24 VDC
Output supply voltage-range	4.5-6 VDC	12-18 VDC	20-30 VDC	4.5-6 VDC	12-18 VDC	20-30 VDC
Output supply current at rated input voltage (see note 2)	18 mA max.	15 mA max.	12 mA max.	18 mA max.	15 mA max.	12 mA max.
Control resistance (Rc in circuit configuration - see note 1)	240 Ω	1 k Ω	2.2 k Ω	240 Ω	1k Ω	2.2k Ω
Output current	50 mA max.					

Characteristics

Item	G3TC-IAC5	G3TC-IAC15	G3TC-IAC24	G3TC-IAC5A	G3TC-IAC15A	G3TC-IAC24A
Operate time (see note 3)	20 ms max.					
Release time (see note 3)	20 ms max.					
Output ON voltage drop	0.4 V max.					
Leakage current	100 μ A max.					
Weight	Approx. 40g					

Note: 1. Resistance values are reference.

2. The input module supplies the current on I/O circuit board at nominal output voltage.

3. At nominal output supply voltage, rated input voltage and 25°C.

■ DC Input Module G3TC-IDC

Ratings (Ambient Temperature 25°C)

Input

Item	G3TC-IDC5	G3TC-IDC15	G3TC-IDC24
Rated voltage	24 VDC/AC		
Operating voltage	10-32 VDC/ 15-32 VAC		
Must operate voltage	10 VDC/15 VAC max.		
Must release voltage	3 VDC/ 3 VAC min.		
Input current rated voltage	25 mA max.		
Input resistance (see note 1)	1.5 k Ω		

Output

Item	G3TC-IDC5	G3TC-IDC15	G3TC-IDC24
Output supply voltage-nominal	5 VDC	15 VDC	24 VDC
Output supply voltage-range	4.5-6 VDC	12-18 VDC	20-30 VDC
Output supply current at rated input voltage (see note 2)	18 mA max.	15 mA max.	12 mA max.
Control resistance (Rc in circuit configuration - see note 1)	240 Ω	1 k Ω	2.2 k Ω
Output current	50 mA max.		

Characteristics

Item	G3TC-IDC5	G3TC-IDC15	G3TC-IDC24
Operate time (see note 3)	5 ms max.		
Release time (see note 3)	5 ms max.		
Output ON voltage drop	0.4 V max.		
Leakage current	100 μ A max.		
Weight	Approx. 40g		

- Note:**
1. Resistance values are reference.
 2. The input module supplies the current on I/O circuit board at nominal output voltage.
 3. At nominal output supply voltage, rated input voltage and 25°C.

■ AC Output Module G3TC-OAC

Ratings (Ambient Temperature 25°C)

Input

Item	G3TC-OAC5	G3TC-OAC15	G3TC-OAC24	G3TC-OAC5A	G3TC-OAC15A	G3TC-OAC24A
Rated voltage	5 VDC	15 VDC	24 VDC	5 VDC	15 VDC	24 VDC
Operating voltage	2.5-8 VDC	9-16 VDC	18-32 VDC	2.5-8 VDC	9-16 VDC	18-32 VDC
Must operate voltage	2.5 VDC max.	9 VDC max.	18 VDC max.	2.5 VDC max.	9 VDC max.	18 VDC max.
Must release voltage	1 VDC min.					
Input current at rated voltage (see note 2)	18 mA max.					
Control resistance (Rc in circuit configuration - see note 1)	240 Ω	1 k Ω	2.2 k Ω	240 Ω	1 k Ω	2.2 k Ω

Output

Item	G3TC-OAC5	G3TC-OAC15	G3TC-OAC24	G3TC-OAC5A	G3TC-OAC15A	G3TC-OAC24A
Rated load voltage	120 VAC			240 VAC		
Load voltage range	75-140 VAC			75-280 VAC		
Load current	0.05 to 3 A					
Inrush current	45 A (60 Hz, 1 cycle)					

Characteristics

Item	G3TC-OAC5	G3TC-OAC15	G3TC-OAC24	G3TC-OAC5A	G3TC-OAC15A	G3TC-OAC24A
Operate time (see note 3)	1/2 of load power source cycle + 1 ms max.					
Release time (see note 3)	1/2 of load power source cycle + 1 ms max.					
Output ON voltage drop	1.6 V (RMS) max.					
Leakage current	2.5 mA max. (at 120 VAC)			5 mA max. (at 240 VAC)		
Weight	Approx. 45g					

- Note:**
1. Resistance values are reference.
 2. The output module supplies the current on I/O circuit board at nominal input voltage.
 3. At nominal output supply voltage, rated input voltage and 25°C.

■ DC Output Module G3TC-ODC

Ratings (Ambient Temperature 25°C)

Input

Item	G3TC-ODC5	G3TC-ODC15	G3TC-ODC24	G3TC-ODC5A	G3TC-ODC15A	G3TC-ODC24A
Rated voltage	5 VDC	15 VDC	24 VDC	5 VDC	15 VDC	24 VDC
Operating voltage	2.5-8 VDC	9-16 VDC	18-32 VDC	2.5-8 VDC	9-16 VDC	18-32 VDC
Must operate voltage	2.5 VDC max.	9 VDC max.	18 VDC max.	2.5 VDC max.	9 VDC max.	18 VDC max.
Must release voltage	1 VDC min.					
Input current at rated voltage (see note 2)	18 mA max.					
Control resistance (Rc in circuit configuration - see note 1)	240 Ω	1 kΩ	2.2 kΩ	240 Ω	1 kΩ	2.2 kΩ

Output

Item	G3TC-ODC5	G3TC-ODC15	G3TC-ODC24	G3TC-ODC5A	G3TC-ODC15A	G3TC-ODC24A
Rated load voltage	60 VDC			200 VDC		
Load voltage range	5-60 VDC			5-200 VDC		
Load current	0.01 to 3 A			0.01 to 1.0 A		
Inrush current	18 A (10 ms)			9 A (10 ms)		

Characteristics

Item	G3TC-ODC5	G3TC-ODC15	G3TC-ODC24	G3TC-ODC5A	G3TC-ODC15A	G3TC-ODC24A
Operate time (see note 3)	50 μs max.			100 μs max.		
Release time (see note 3)	50 μs max. (see note 4)			750 μs max.		
Output ON voltage drop	1.6 V max.					
Leakage current	1 mA max. (at 60 VDC)			1 mA max. (at 200 VDC)		
Weight	Approx. 45g			Approx. 40g		

Note: 1. Resistance values are reference.

2. The output module supplies the current on I/O circuit board at nominal input voltage.
3. At rated load voltage, maximum rated load current, rated input voltage and 25°C.
4. At 24 VDC load voltage, 3 A load current and 25°C.

Engineering Data

Internal Circuit

G3TC-IAC/IDC

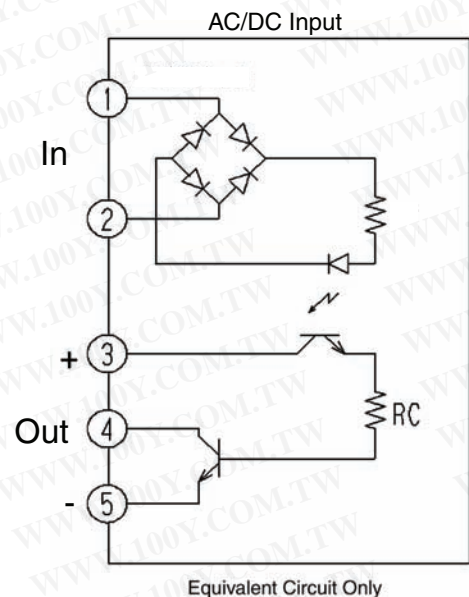

G3TC-OAC

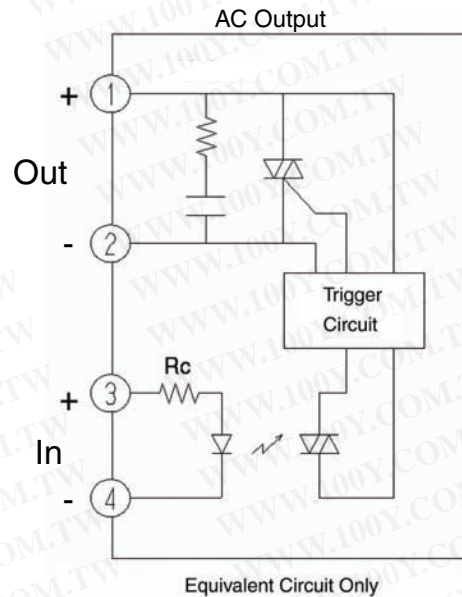

Note: Internal biasing circuitry is different between AC input and DC input modules

G3TC-ODC

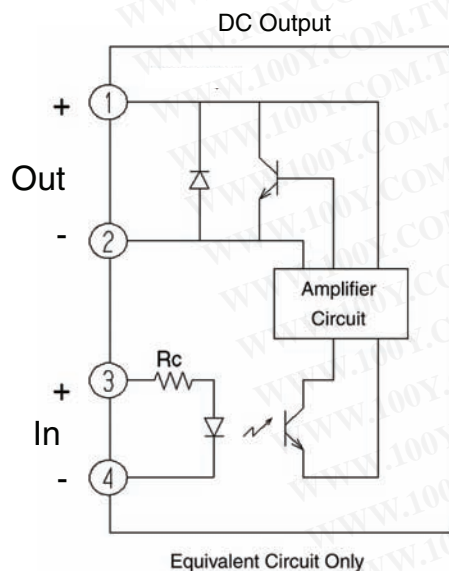

Load Current vs. Ambient Temperature Characteristics

G3TC-ODC5
G3TC-ODC15
G3TC-ODC24

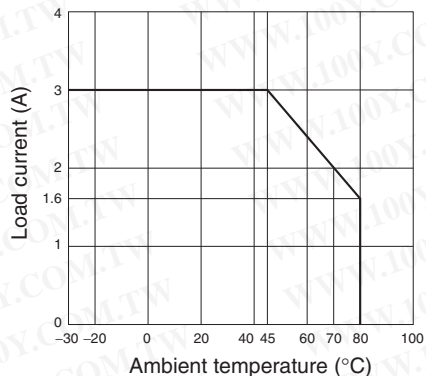

G3TC-ODC5A
G3TC-ODC15A
G3TC-ODC24A

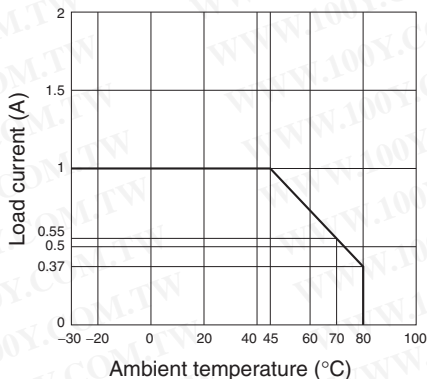

G3TC-OAC5
G3TC-OAC15
G3TC-OAC24

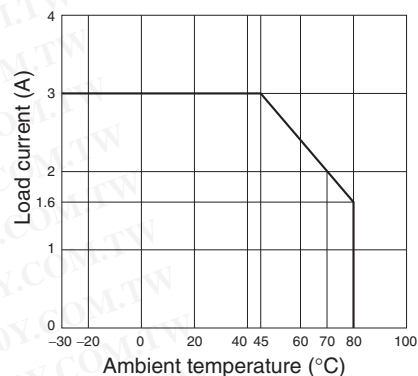

G3TC-OAC5A
G3TC-OAC15A
G3TC-OAC24A

Inrush Current Resitivity

Non-repetitive (Keep inrush current to half the rated value if it occurs.)

G3TC-ODC5
G3TC-ODC15
G3TC-ODC24

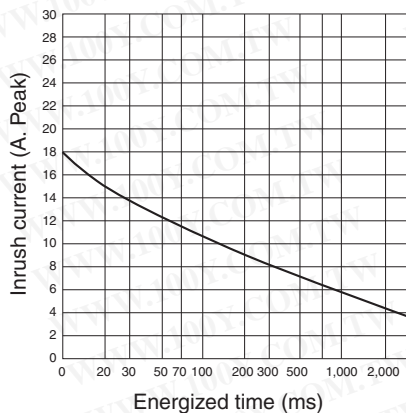

G3TC-ODC5A
G3TC-ODC15A
G3TC-ODC24A

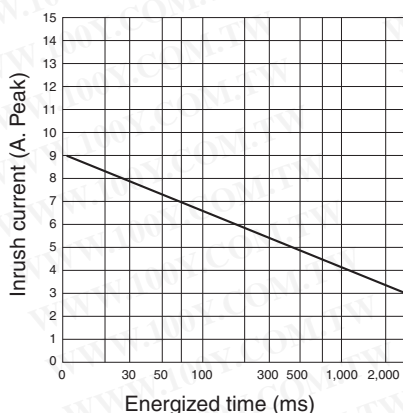

G3TC-OAC5
G3TC-OAC15
G3TC-OAC24

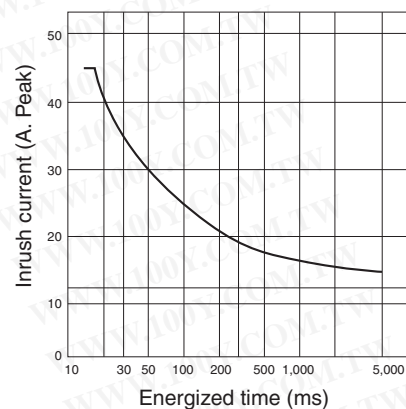

G3TC-OAC5A
G3TC-OAC15A
G3TC-OAC24A

Dimensions

Note: All units are in millimeters unless otherwise indicated.

- G3TC-IAC5 G3TC-IAC5A
- G3TC-IAC15 G3TC-IAC15A
- G3TC-IAC24 G3TC-IAC24A

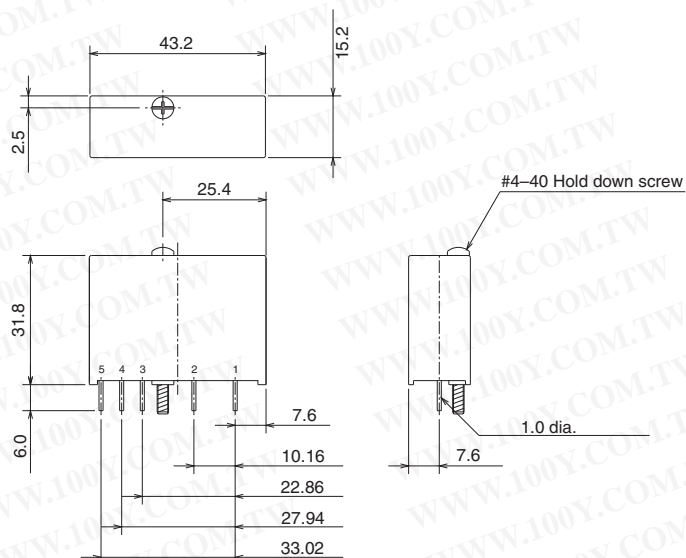
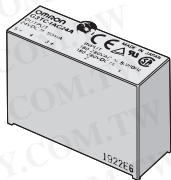

- G3TC-IDC5
- G3TC-IDC15
- G3TC-IDC24

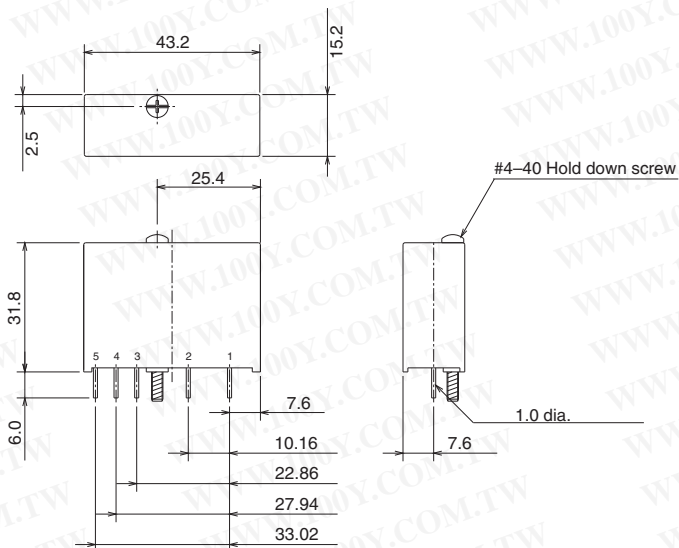

- G3TC-OAC5 G3TC-OAC5A
- G3TC-OAC15 G3TC-OAC15A
- G3TC-OAC24 G3TC-OAC24A

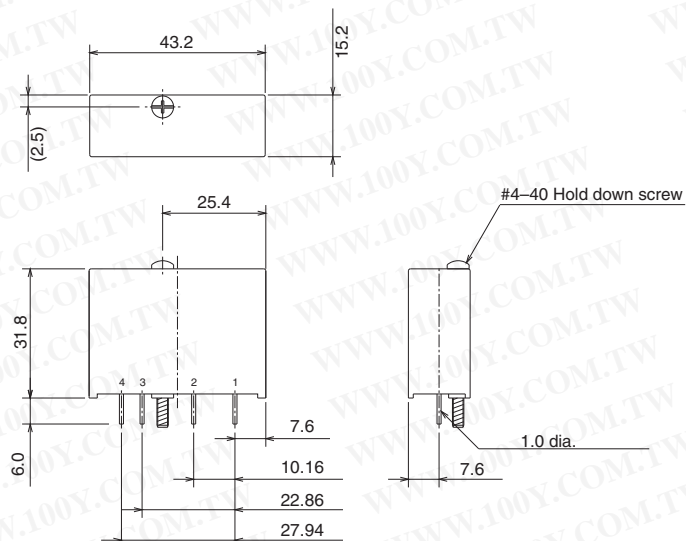

G3TC-ODC5 G3TC-ODC5A
 G3TC-ODC15 G3TC-ODC15A
 G3TC-ODC24 G3TC-ODC24A

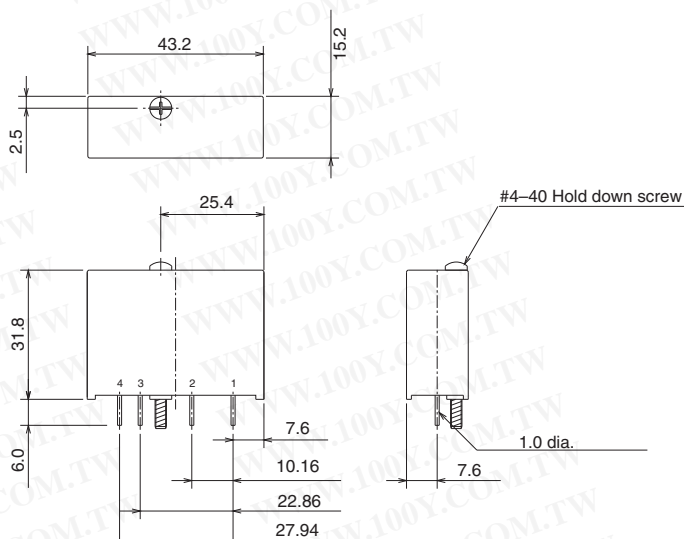
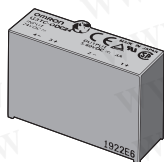

Approvals

UL Recognized (File No. E64562) / CSA Certified (File No. 35535) - - Ambient Temp. = 40°C

Input

Model	Input voltage
G3TC-IAC5, -IAC15, -IAC24	90-140 V AC/DC
G3TC-IAC5A, -IAC15A, -IAC24A	180-280 V AC/DC
G3TC-IDC5, -IDC15, -IDC24	10-32 VDC, 12-32 VAC
G3TC-ODC5, -ODC5A, -OAC5, -OAC5A	5 VDC
G3TC-ODC15, -ODC15A, -OAC15, -OAC15A	15 VDC
G3TC-ODC24, -ODC24A, -OAC24, -OAC24A	24 VDC

Output

Model	Load voltage	Load current
G3TC-IAC5, -IAC15, -IAC24	5/15/24 VDC	50 mA
G3TC-IAC5A, -IAC15A, -IAC24A	5/15/24 VDC	50 mA
G3TC-IDC5, -IDC15, -IDC24	5/15/24 VDC	50 mA
G3TC-ODC5, -ODC15, -ODC24	5-60 VDC	3 A
G3TC-ODC5A, -ODC15A, -ODC24A	5-200 VDC	1 A
G3TC-OAC5, -OAC15, -OAC24	75-140 VAC	3 A
G3TC-OAC5A, -OAC15A, -OAC24A	75-280 VAC	3 A

Note: The rated values approved by each of the safety standards (e.g., UL, CSA and TUV) may be different from the performance characteristics individually defined in this catalog.

Precautions

WARNING
Do not touch the relay while power is supplied or immediately after G3TC is turned OFF. Doing so may result in burns.

WARNING
Do not touch the load terminal of the G3TC immediately after the power is turned OFF, otherwise an electric shock may be received due to the residual charge of the built-in C/R circuit.

WARNING
Be sure to turn OFF the power supply to the G3TC before wiring, otherwise an electric shock may result.

WARNING
Ensure that a short-circuit current does not flow on the load side of the SSR, otherwise the G3TC may be damaged.

General Precautions

At OMRON, we are constantly working to improve the quality and reliability of our products. SSRs, however, use semiconductors, which are prone to malfunction. Be sure to use SSRs within their rated value. Use the SSR only in systems that are designed with redundancies, flame protection, counter measures to prevent operation errors, and other countermeasures to prevent accidents involving human life or fires.

1. Do not apply excessive voltage or current to the input or output circuit of the G3TC. Doing so may result in malfunction or burning.
2. Do not connect the input and output circuits incorrectly. Doing so may result in malfunction or burning.
3. Do not obstruct the flow of air around the G3TC. Abnormal heating of the G3TC may result in short-circuiting of output elements and burning.

Correct Use

Before Actual Operation

1. In actual operation, the G3TC may cause accidents that were unforeseeable at the theoretical stage. Therefore, it is necessary to test the G3TC under a variety of conditions that are possible. As for the characteristics of the G3TC, it is necessary to consider the differences between G3TC models.
2. The ratings in this datasheet are for testing in a temperature range of 15 to 30°C, a relative humidity range of 25% to 85%, and an atmospheric pressure range of 88 to 106kPa. When testing operation, it is necessary to confirm correct operation not only with the actual load that will be used, but also at the same ambient conditions as for actual operation.
3. The input circuitry does not incorporate a circuit protecting the SSR from being damaged due to a reversed connection. Make sure that the polarity is correct when connecting the input lines.
4. Only use the G3TC with loads that are within the rated values. Using the G3TC with loads outside the rated values may result in malfunction, damage, or burning.
5. Use a power supply within the rated frequency range. Using a power supply outside the rated frequency range may result in malfunction, damage, or burning.
6. No over-voltage absorption element is built in. Therefore, if the G3TC is connected to an inductive load, be sure to connect an over-voltage absorption element.
7. As protection against accidents due to short-circuiting, be sure to install protective devices, such as fuses on the power supply side.
8. Keep wiring separate from high-voltage power lines and use wires of an appropriate length, otherwise malfunction and damage may result due to induction.

9. For a DC inductive load, a diode should be connected in parallel with the load to absorb the counter electromotive force of the load.
10. For an I/O mounting rack that is installed horizontally, use the G3TC with loads that are within the following conditions.

G3TC-OAC5, -OAC5A, -OAC15, -OAC15A, -OAC24, -OAC24A

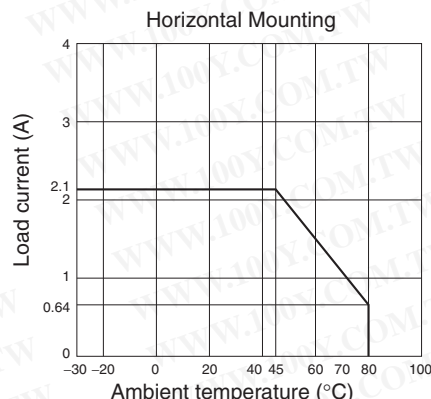

G3TC-ODC5, -ODC15, -ODC24

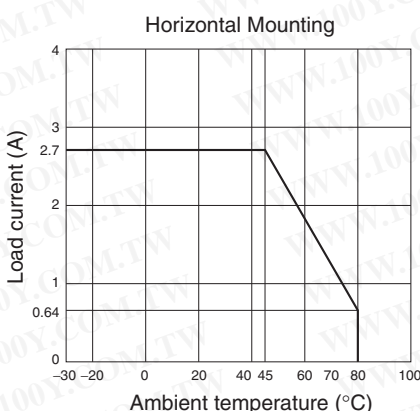

■ Operating and Storage Environments

Operating Ambient Temperature

The rated value for the ambient operating temperature of the G3TC is for when there is no built-up heat. For this, reason, under conditions where heat dissipation is not good due to poor ventilation, and where heat may build up easily, the actual temperature of the G3TC may exceed the rated value resulting in malfunction or burning.

When using the G3TC, design the system to allow heat dissipation sufficient to stay below the Load Current vs. Ambient Temperature characteristic curve. Note also that the ambient temperature of the G3TC may increase as a result of environmental conditions (e.g., climate, air-conditioning) and operating conditions (e.g., mounting in an airtight panel).

Operating and Storage Locations

Do not use or store the G3TC in the following locations. Doing so may result in damage, malfunction, or deterioration of performance characteristics.

1. Do not use or store in locations subject to direct sunlight.
2. Do not use in locations subject to ambient temperatures outside the range -30° to 80°C .
3. Do not use in locations subject to relative humidity outside the range 45% to 85% or locations subject to condensation as the result of severe change in temperature.
4. Do not store in locations subject to ambient temperatures outside the range -30° to 100°C .
5. Do not use or store in locations subject to corrosive or flammable gases.
6. Do not use or store in locations subject to dust (especially iron dust) or salts.
7. Do not use or store in locations subject to shock or vibration.
8. Do not use or store in locations subject to exposure to water, oil, or chemicals.

Transportation

When transporting the G3TC, observe the following points. Not doing so may result in damage, malfunction, or deterioration of performance characteristics.

1. Do not drop the G3TC or subject it to severe vibrations or shock.
2. Do not transport the product if it is wet.

Vibration and Shock

Do not subject the SSR to excessive vibration or shock. Otherwise the SSR may malfunction and internal components may be damaged.

MEMO

A large grid of dashed lines for writing notes, consisting of 20 columns and 30 rows. The grid is used for taking notes or recording information.

Omron Electronic Components, LLC

Terms and Conditions of Sales

I. GENERAL

- Definitions:** The words used herein are defined as follows.
 - Terms:** These terms and conditions
 - Seller:** Omron Electronic Components LLC and its subsidiaries
 - Buyer:** The buyer of Products, including any end user in section III through VI
 - Products:** Products and/or services of Seller
 - Including:** Including without limitation
- Offer; Acceptance:** These Terms are deemed part of all quotations, acknowledgments, invoices, purchase orders and other documents, whether electronic or in writing, relating to the sale of Products by Seller. Seller hereby objects to any Terms proposed in Buyer's purchase order or other documents which are inconsistent with, or in addition to, these Terms.
- Distributor:** Any distributor shall inform its customer of the contents after and including section III of these Terms.

II. SALES

- Prices; Payment:** All prices stated are current, subject to change without notice by Seller. Buyer agrees to pay the price in effect at the time the purchase order is accepted by Seller. Payments for Products received are due net 30 days unless otherwise stated in the invoice. Buyer shall have no right to set off any amounts against the amount owing in respect of this invoice.
- Discounts:** Cash discounts, if any, will apply only on the net amount of invoices sent to Buyer after deducting transportation charges, taxes and duties, and will be allowed only if (a) the invoice is paid according to Seller's payment terms and (b) Buyer has no past due amounts owing to Seller.
- Interest:** Seller, at its option, may charge Buyer 1.5% interest per month or the maximum legal rate, whichever is less, on any balance not paid within the stated terms.
- Orders:** Seller will accept no order less than 200 U.S. dollars net billing.
- Currencies:** If the prices quoted herein are in a currency other than U.S. dollars, Buyer shall make remittance to Seller at the then current exchange rate most favorable to Seller; provided that if remittance is not made when due, Buyer will convert the amount to U.S. dollars at the then current exchange rate most favorable to Seller available during the period between the due date and the date remittance is actually made.
- Governmental Approvals:** Buyer shall be responsible for all costs involved in obtaining any government approvals regarding the importation or sale of the Products.
- Taxes:** All taxes, duties and other governmental charges (other than general real property and income taxes), including any interest or penalties thereon, imposed directly or indirectly on Seller or required to be collected directly or indirectly by Seller for the manufacture, production, sale, delivery, importation, consumption or use of the Products sold hereunder (including customs duties and sales, excise, use, turnover and license taxes) shall be charged to and remitted by Buyer to Seller.
- Financial:** If the financial position of Buyer at any time becomes unsatisfactory to Seller, Seller reserves the right to stop shipments or require satisfactory security or payment in advance. If Buyer fails to make payment or otherwise comply with these Terms or any related agreement, Seller may (without liability and in addition to other remedies) cancel any unshipped portion of Products sold hereunder and stop any Products in transit until Buyer pays all amounts, including amounts payable hereunder, whether or not then due, which are owing to it by Buyer. Buyer shall in any event remain liable for all unpaid accounts.
- Cancellation; Etc:** Orders are not subject to rescheduling or cancellation unless Buyer indemnifies Seller fully against all costs or expenses arising in connection therewith.
- Force Majeure:** Seller shall not be liable for any delay or failure in delivery resulting from causes beyond its control, including earthquakes, fires, floods, strikes or other labor disputes, shortage of labor or materials, accidents to machinery, acts of sabotage, riots, delay in or lack of transportation or the requirements of any government authority.
- Shipping; Delivery:** Unless otherwise expressly agreed in writing by Seller:
 - All sales and shipments of Products shall be FOB shipping point (unless otherwise stated in writing by Seller), at which point title to and all risk of loss of the Products shall pass from Seller to Buyer, provided that Seller shall retain a security interest in the Products until the full purchase price is paid by Buyer;
 - Delivery and shipping dates are estimates only; and
 - Seller will package Products as it deems proper for protection against normal handling and extra charges apply to special conditions.
- Claims:** Any claim by Buyer against Seller for shortage or damage to the Products occurring before delivery to the carrier or any claim related to pricing or other charges must be presented in detail in writing to Seller within 30 days of receipt of shipment.

III. PRECAUTIONS

- Suitability:** IT IS THE BUYER'S SOLE RESPONSIBILITY TO ENSURE THAT ANY OMRON PRODUCT IS FIT AND SUFFICIENT FOR USE IN A MOTORIZED VEHICLE APPLICATION. BUYER SHALL BE SOLELY RESPONSIBLE FOR DETERMINING APPROPRIATENESS OF THE PARTICULAR PRODUCT WITH RESPECT TO THE BUYER'S APPLICATION INCLUDING (A) ELECTRICAL OR ELECTRONIC COMPONENTS, (B) CIRCUITS, (C) SYSTEM ASSEMBLIES, (D) END PRODUCT, (E) SYSTEM, (F) MATERIALS OR SUBSTANCES OR (G) OPERATING ENVIRONMENT. Buyer acknowledges that it alone has determined that the Products will meet their requirements of the intended use in all cases. Buyer must know and observe all prohibitions of use applicable to the Product/s.
- Use with Attention:** The followings are some examples of applications for which particular attention must be given. This is not intended to be an exhaustive list of all possible use of any Product, nor to imply that any use listed may be suitable for any Product:
 - Outdoor use, use involving potential chemical contamination or electrical interference.

- Use in consumer Products or any use in significant quantities.
 - Energy control systems, combustion systems, railroad systems, aviation systems, medical equipment, amusement machines, vehicles, safety equipment, and installations subject to separate industry or government regulations.
 - Systems, machines, and equipment that could present a risk to life or property.
- Prohibited Use:** NEVER USE THE PRODUCT FOR AN APPLICATION INVOLVING SERIOUS RISK TO LIFE OR PROPERTY WITHOUT ENSURING THAT THE SYSTEM AS A WHOLE HAS BEEN DESIGNED TO ADDRESS THE RISKS, AND THAT THE PRODUCT IS PROPERLY RATED AND INSTALLED FOR THE INTENDED USE WITHIN THE OVERALL EQUIPMENT OR SYSTEM.
 - Motorized Vehicle Application:** USE OF ANY PRODUCT/S FOR A MOTORIZED VEHICLE APPLICATION MUST BE EXPRESSLY STATED IN THE SPECIFICATION BY SELLER.
 - Programmable Products:** Seller shall not be responsible for the Buyer's programming of a programmable Product.

IV. WARRANTY AND LIMITATION

- Warranty:** Seller's exclusive warranty is that the Products will be free from defects in materials and workmanship for a period of twelve months from the date of sale by Seller (or such other period expressed in writing by Seller). SELLER MAKES NO WARRANTY OR REPRESENTATION, EXPRESS OR IMPLIED, ABOUT ALL OTHER WARRANTIES, NON-INFRINGEMENT, MERCHANTABILITY OR FITNESS FOR A PARTICULAR PURPOSE OF THE PRODUCTS.
- Buyer Remedy:** Seller's sole obligation hereunder shall be to replace (in the form originally shipped with Buyer responsible for labor charges for removal or replacement thereof) the non-complying Product or, at Seller's election, to repay or credit Buyer an amount equal to the purchase price of the Product; provided that there shall be no liability for Seller or its affiliates unless Seller's analysis confirms that the Products were correctly handled, stored, installed and maintained and not subject to contamination, abuse, misuse or inappropriate modification. Return of any Products by Buyer must be approved in writing by Seller before shipment.
- Limitation on Liability:** SELLER AND ITS AFFILIATES SHALL NOT BE LIABLE FOR SPECIAL, INDIRECT, INCIDENTAL OR CONSEQUENTIAL DAMAGES, LOSS OF PROFITS OR PRODUCTION OR COMMERCIAL LOSS IN ANY WAY CONNECTED WITH THE PRODUCTS, WHETHER SUCH CLAIM IS BASED IN CONTRACT, WARRANTY, NEGLIGENCE OR STRICT LIABILITY. FURTHER, IN NO EVENT SHALL LIABILITY OF SELLER OR ITS AFFILIATES EXCEED THE INDIVIDUAL PRICE OF THE PRODUCT ON WHICH LIABILITY IS ASSERTED.
- Indemnities:** Buyer shall indemnify and hold harmless Seller, its affiliates and its employees from and against all liabilities, losses, claims, costs and expenses (including attorney's fees and expenses) related to any claim, investigation, litigation or proceeding (whether or not Seller is a party) which arises or is alleged to arise from Buyer's acts or omissions under these Terms or in any way with respect to the Products.

V. INFORMATION; ETC.

- Intellectual Property:** The intellectual property embodied in the Products is the exclusive property of Seller and its affiliates and Buyer shall not attempt to duplicate it in any way without the written permission of Seller. Buyer (at its own expense) shall indemnify and hold harmless Seller and defend or settle any action brought against Seller to the extent that it is based on a claim that any Product made to Buyer specifications infringed intellectual property rights of another party.
- Property; Confidentiality:** Notwithstanding any charges to Buyer for engineering or tooling, all engineering and tooling shall remain the exclusive property of Seller. All information and materials supplied by Seller to Buyer relating to the Products are confidential and proprietary, and Buyer shall limit distribution thereof to its trusted employees and strictly prevent disclosure to any third party.
- Performance Data:** Performance data is provided as a guide in determining suitability and does not constitute a warranty. It may represent the result of Seller's test conditions, and the users must correlate it to actual application requirements.
- Change In Specifications:** Product specifications and descriptions may be changed at any time based on improvements or other reasons. It is Seller's practice to change part numbers when published ratings or features are changed, or when significant engineering changes are made. However, some specifications of the Product may be changed without any notice.
- Errors And Omissions:** The information on Seller's website or in other documentation has been carefully checked and is believed to be accurate; however, no responsibility is assumed for clerical, typographical or proofreading errors or omissions.
- Export Controls:** Buyer shall comply with all applicable laws, regulations and licenses regarding (a) export of the Products or information provided by Seller; (b) sale of Products to forbidden or other proscribed persons or organizations; (c) disclosure to non-citizens of regulated technology or information.

VI. MISCELLANEOUS

- Waiver:** No failure or delay by Seller in exercising any right and no course of dealing between Buyer and Seller shall operate as a waiver of rights by Seller.
- Assignment:** Buyer may not assign its rights hereunder without Seller's written consent.
- Law:** These Terms are governed by Illinois law (without regard to conflict of laws). Federal and state courts in Cook County, Illinois have exclusive jurisdiction for any dispute hereunder.
- Amendment:** These Terms constitute the entire agreement between Buyer and Seller relating to the Products, and no provision may be changed or waived unless in writing signed by the parties.
- Severability:** If any provision hereof is rendered ineffective or invalid, such provision shall not invalidate any other provision.

Certain Precautions on Specifications and Use

1. **Suitability for Use.** Seller shall not be responsible for conformity with any standards, codes or regulations which apply to the combination of the Product in Buyer's application or use of the Product. At Buyer's request, Seller will provide applicable third party certification documents identifying ratings and limitations of use which apply to the Product. This information by itself is not sufficient for a complete determination of the suitability of the Product in combination with the end product, machine, system, or other application or use. Buyer shall be solely responsible for determining appropriateness of the particular Product with respect to Buyer's application, product or system. Buyer shall take application responsibility in all cases but the following is a non-exhaustive list of applications for which particular attention must be given:
 - (i) Outdoor use, uses involving potential chemical contamination or electrical interference, or conditions or uses not described in this document.
 - (ii) Energy control systems, combustion systems, railroad systems, aviation systems, medical equipment, amusement machines, vehicles, safety equipment, and installations subject to separate industry or government regulations.
 - (iii) Use in consumer products or any use in significant quantities.
 - (iv) Systems, machines and equipment that could present a risk to life or property. Please know and observe all prohibitions of use applicable to this product.

NEVER USE THE PRODUCT FOR AN APPLICATION INVOLVING SERIOUS RISK TO LIFE OR PROPERTY WITHOUT ENSURING THAT THE SYSTEM AS A WHOLE HAS BEEN DESIGNED TO ADDRESS THE RISKS, AND THAT THE OMRON PRODUCT IS PROPERLY RATED AND INSTALLED FOR THE INTENDED USE WITHIN THE OVERALL EQUIPMENT OR SYSTEM.
2. **Programmable Products.** Seller shall not be responsible for the user's programming of a programmable product, or any consequence thereof.
3. **Performance Data.** Performance data given in this publication is provided as a guide for the user in determining suitability and does not constitute a warranty. It may represent the result of Seller's test conditions, and the users must correlate it to actual application requirements. Actual performance is subject to Seller's Warranty and Limitations of Liability.
4. **Change in Specifications.** Product specifications and accessories may be changed at any time based on improvements and other reasons. It is our practice to change part numbers when published ratings or features are changed, or when significant construction changes are made. However, some specifications of the Product may be changed without any notice. When in doubt, special part numbers may be assigned to fix or establish key specifications for your application. Please consult with your Seller representative at any time to confirm actual specifications of purchased Product.
5. **Errors and Omissions.** The information in this publication has been carefully checked and is believed to be accurate; however, no responsibility is assumed for clerical, typographical or proofreading errors, or omissions.
6. **RoHS Compliance.** Where indicated, our products currently comply, to the best of our knowledge as of the date of this publication, with the requirements of the European Union's Directive on the Restriction of certain Hazardous Substances ("RoHS"), although the requirements of RoHS do not take effect until July 2006. These requirements may be subject to change. Please consult our website for current information.

勝特力材料 886-3-5753170
 勝特力电子(上海) 86-21-34970699
 勝特力电子(深圳) 86-755-83298787
[Http://www.100y.com.tw](http://www.100y.com.tw)

Complete "Terms and Conditions of Sale" for product purchase and use are on Omron's website at <http://www.components.omron.com> – under the "About Us" tab, in the Legal Matters section.

ALL DIMENSIONS SHOWN ARE IN MILLIMETERS.

To convert millimeters into inches, multiply by 0.03937. To convert grams into ounces, multiply by 0.03527.

OMRON

**OMRON ELECTRONIC
COMPONENTS LLC**

55 E. Commerce Drive, Suite B
Schaumburg, IL 60173

847-882-2288

OMRON ON-LINE

Global - <http://www.omron.com>

USA - <http://www.components.omron.com>