



Power Relay

TRIL

MAIN FEATURES

- 16A switching capabilities.
- 1 & 2 pole configurations.
- 5KV/10mm dielectric coil to contacts.
- Low height of 15.7mm.
- Sealed & Unsealed types available.
- UL & cUL recognized.

APPLICATIONS

- Microwave Oven; Facsimile; Refrigerator, Air Conditioner, Conditioner, Stereo Equipment; Copiers, TV Set, Monitor, Vending Machine, Temperature Controller, etc.

ORDERING INFORMATION

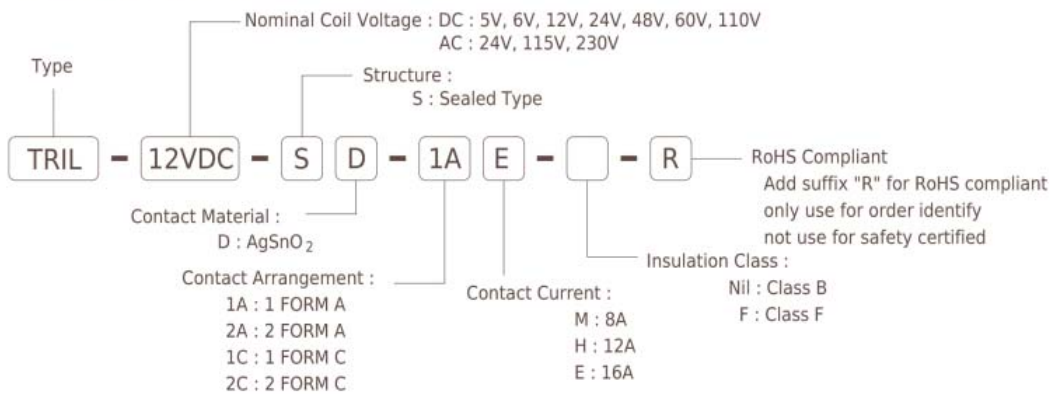

DIMENSION(unit:mm)

DRILLING(unit:mm)

WIRING DIAGRAM

M Type

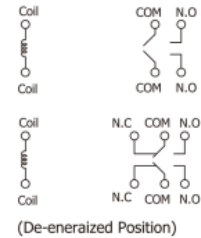
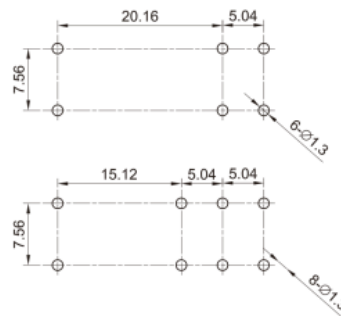
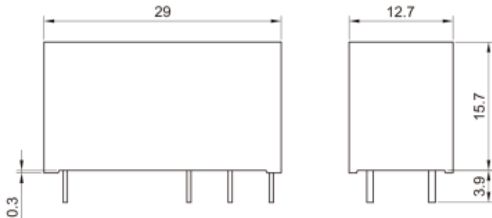

H Type

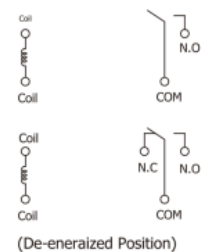
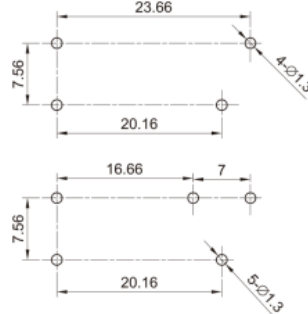
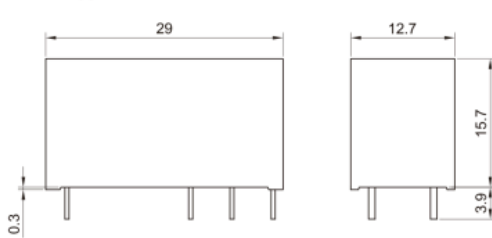

1. Tolerance ±0.5mm on all dimensions unless otherwise stated.
2. Tolerance ±0.1mm on PCB DRILLING dimension unless otherwise stated.

DIMENSION(unit:mm)

DRILLING(unit:mm)

WIRING DIAGRAM

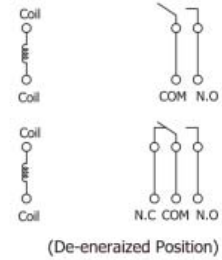
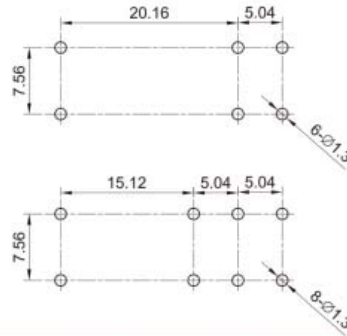
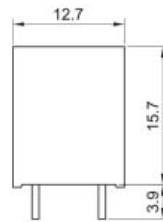
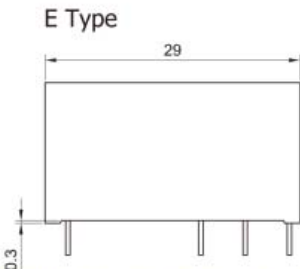

COIL DATA CHART(at 20°C)

Coil Sensitivity	Nominal Voltage (VDC)	Nominal Current (mA)	Coil Resistance ($\Omega \pm 10\%$)	Power Consumption (W)	Pull-In Voltage (VDC)	Drop-Out Voltage (VDC)	Max-Allowable Voltage (VDC)
TRIL (DC TYPE)	5	80.6	62	abt. 0.4W	70% Max.	10% Min.	110% Max.
	6	66.7	90				
	12	33.3	360				
	24	16.7	1440				
	48	8.3	5760 $\pm 15\%$				
	60	8.0	7500 $\pm 15\%$				
TRIL (AC TYPE)	110	4.3	25200 $\pm 15\%$	abt. 0.75VA	75% Max.	15% Min.	110% Max.
	24	31.6	350				
	115	17.3	8100 $\pm 15\%$				
	230	34.5	32500 $\pm 15\%$				

CONTACT RATING

Item	SPST (1A), SPDT (1C)		DPST (2A), DPDT (2C)
	TRIL -E	TRIL -H	TRIL -M
Contact Capacity			
Resistive Load ($\cos\phi=1$)	16A 250VAC	12A 250VAC	8A 250VAC
Rated Carrying Current	16A	12A	8A
Max. Switching Voltage	440VAC		
Contact Current(Res. Load)	10A	10A	5A
Max. Allowable Power Force	4000VA	3000VA	2000VA
Contact Material	Silver Alloy		

PERFORMANCE(at initial value)

Item	TRIL
Contact resistance	100m Ω max (measured at 1A 6VDC).
Operation time	15msec max.
Release time	8msec max.
Insulation resistance	1000 M Ω min. (at 500VDC)
Dielectric strength	
Between coil & contacts	5000VAC, 1min
Between open contacts	1000VAC, 1min
Between contact sets	2500VAC, 1min
Surge voltage (between coil & contacts)	10KV(1.2 x 50us)
Temperature rise(at nomi.volt.)	55K max. (DC TYPE)/ 65K max. (AC TYPE)
Shock resistance	Functional
	Destructive
Vibration resistance	98 m/s ²
	980 m/s ²
Vibration resistance	10 to 150Hz 10g/5g
Operating ambient temperature	(DC TYPE) -40°C to +85°C. (AC TYPE) -40°C to +70°C.
Operating humidity	35% to 85% RH
Life expectancy	
Mechanically	1 x 10 ⁷ ops. Min.
Electrically	1 x 10 ⁵ ops. Min.(DC TYPE) 5 x 10 ⁵ ops. Min.(AC TYPE)
Weight	abt. 13.5g.
UL & cUL	E156406

Only for reference, won't notify if any change.