

SILICON PNP TRANSISTORS

- SGS-THOMSON PREFERRED SALESTYPES
- PNP TRANSISTOR

DESCRIPTION

The 2N5415, 2N5416 are high voltage silicon epitaxial planar PNP transistors in Jedec TO-39 metal case designed for use in consumer and industrial line-operated applications.

These devices are particularly suited as drivers in high-voltage low current inverters, switching and series regulators.

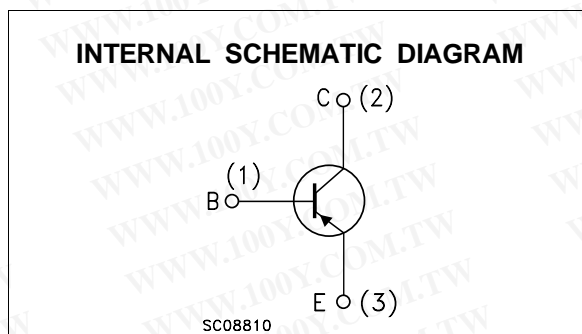
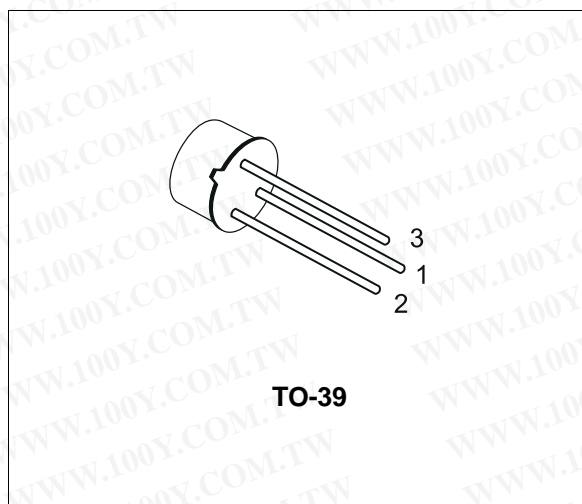

ABSOLUTE MAXIMUM RATINGS

Symbol	Parameter	Value		Unit
		2N5415	2N5416	
V_{CBO}	Collector-Base Voltage ($I_E = 0$)	-200	-350	V
V_{CEO}	Collector-Emitter Voltage ($I_B = 0$)	-200	-300	V
V_{EBO}	Emitter-Base Voltage ($I_C = 0$)	-4	-6	V
I_C	Collector Current	-1		A
I_B	Base Current	-0.5		A
P_{tot}	Total Dissipation at $T_c \leq 25^\circ\text{C}$	10		W
P_{tot}	Total Dissipation at $T_{amb} \leq 50^\circ\text{C}$	1		W
T_{stg}	Storage Temperature	-65 to 200		$^\circ\text{C}$
T_j	Max. Operating Junction Temperature	200		$^\circ\text{C}$

勝特力材料 886-3-5753170
 勝特力电子(上海) 86-21-54151736
 勝特力电子(深圳) 86-755-83298787
[Http://www.100y.com.tw](http://www.100y.com.tw)

2N5415 / 2N5416

THERMAL DATA

R _{thj-case}	Thermal Resistance Junction-case	Max	17.5	°C/W
R _{thj-amb}	Thermal Resistance Junction-ambient	Max	175	°C/W

ELECTRICAL CHARACTERISTICS (T_{case} = 25 °C unless otherwise specified)

Symbol	Parameter	Test Conditions	Min.	Typ.	Max.	Unit
I _{CB0}	Collector Cut-off Current (I _E = 0)	for 2N5415 V _{CB} = -175 V for 2N5416 V _{CB} = -280 V			-50 -50	μA μA
I _{CEO}	Collector Cut-off Current (I _B = 0)	V _{CE} = -150 V			-50	μA
I _{EBO}	Emitter Cut-off Current (I _C = 0)	for 2N5415 V _{EB} = -4 V for 2N5416 V _{EB} = -6 V			-20 -20	μA μA
V _{CER*}	Collector-Emitter Sustaining Voltage	I _C = -50 mA R _{BE} = 50Ω for 2N5416	-350			V
V _{CEO(sus)*}	Collector-Emitter Sustaining Voltage	I _C = -10 mA for 2N5415 for 2N5416	-200 -300			V V
V _{CE(sat)*}	Collector-Emitter Saturation Voltage	I _C = -50 mA I _B = -5 mA			-2.5	V
V _{BE*}	Base-Emitter Voltage	I _C = -50 mA V _{CE} = -10 V			-1.5	V
h _{FE*}	DC Current Gain	I _C = -50 mA V _{CE} = -10 V for 2N5415 for 2N5416	30 30		150 120	
h _{fe}	Small Signal Current Gain	I _C = -5 mA V _{CE} = -10 V f = 1KHz	25			
f _T	Transition frequency	I _C = -10 mA V _{CE} = -10 V f = 5MHz	15			MHz
C _{CB0}	Collector Base Capacitance	I _E = 0 V _{CB} = -10 V f = 1MHz			25	pF

* Pulsed: Pulse duration = 300 μs, duty cycle 1.5 %

TO-39 MECHANICAL DATA

DIM.	mm			inch		
	MIN.	TYP.	MAX.	MIN.	TYP.	MAX.
A	12.7			0.500		
B			0.49			0.019
D			6.6			0.260
E			8.5			0.334
F			9.4			0.370
G	5.08			0.200		
H			1.2			0.047
I			0.9			0.035
L	45° (typ.)					

