

2SA683, 2SA684

Silicon PNP epitaxial planer type

For low-frequency power amplification and driver amplification

Complementary to 2SC1383 and 2SC1384

勝特力材料 886-3-5753170
 勝特力电子(上海) 86-21-54151736
 勝特力电子(深圳) 86-755-83298787
[Http://www.100y.com.tw](http://www.100y.com.tw)

Features

- Complementary pair with 2SC1383 and 2SC1384.
- Allowing supply with the radial taping.

Absolute Maximum Ratings (Ta=25°C)

Parameter	Symbol	Rated	Unit
Collector to base voltage	V _{CB0}	-30	V
2SA683			
2SA684		-60	
Collector to emitter voltage	V _{CEO}	-25	V
2SA683			
2SA684		-50	
Emitter to base voltage	V _{EBO}	-5	V
Peak collector current	I _{CP}	-1.5	A
Collector current	I _C	-1	A
Collector power dissipation	P _C	1	W
Junction temperature	T _j	150	°C
Storage temperature	T _{stg}	-55 ~ +150	°C

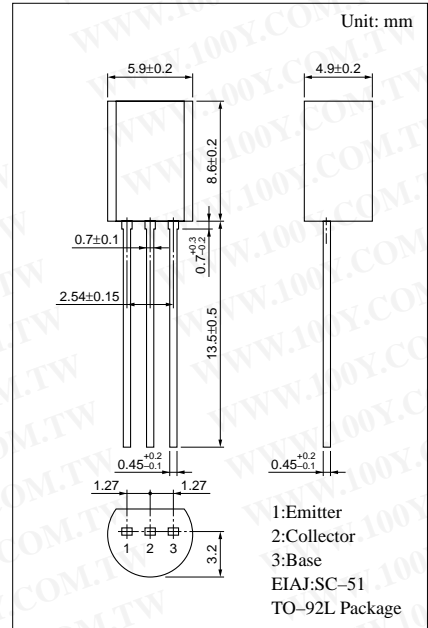

Electrical Characteristics (Ta=25°C)

Parameter	Symbol	Conditions	min	typ	max	Unit
Collector cutoff current	I _{CB0}	V _{CB} = -20V, I _E = 0			-0.1	μA
Collector to base voltage	V _{CB0}	I _C = -10μA, I _E = 0	-30			V
			-60			
Collector to emitter voltage	V _{CEO}	I _C = -2mA, I _B = 0	-25			V
			-50			
Emitter to base voltage	V _{EBO}	I _E = -10μA, I _C = 0	-5			V
Forward current transfer ratio	h _{FE1} *	V _{CE} = -10V, I _C = -500mA	85		340	
	h _{FE2}	V _{CE} = -5V, I _C = -1A	50			
Collector to emitter saturation voltage	V _{CE(sat)}	I _C = -500mA, I _B = -50mA		-0.2	-0.4	V
Base to emitter saturation voltage	V _{BE(sat)}	I _C = -500mA, I _B = -50mA		-0.85	-1.2	V
Transition frequency	f _T	V _{CB} = -10V, I _E = 50mA, f = 200MHz		200		MHz
Collector output capacitance	C _{ob}	V _{CB} = -10V, I _E = 0, f = 1MHz		20	30	pF

*h_{FE1} Rank classification

Rank	Q	R	S
h _{FE1}	85 ~ 170	120 ~ 240	170 ~ 340

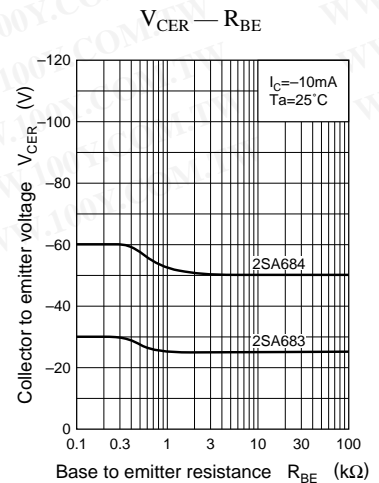
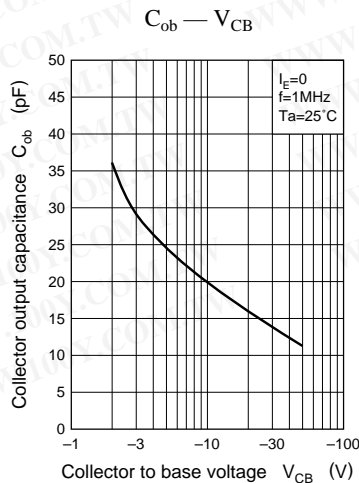
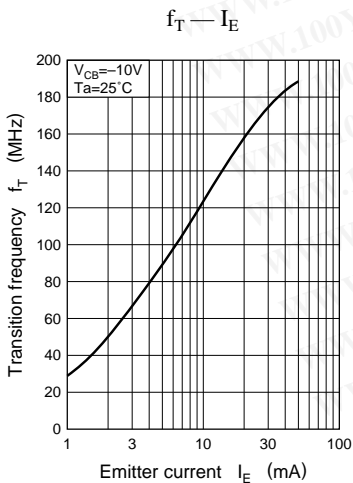
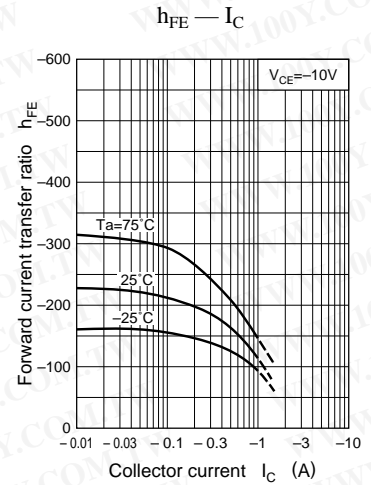
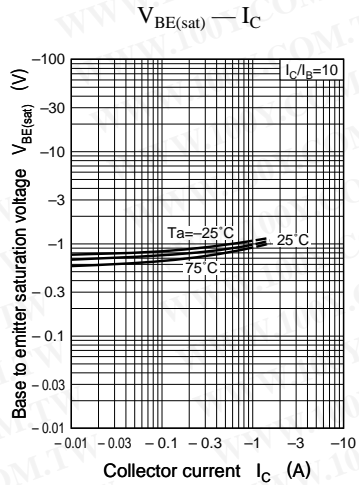
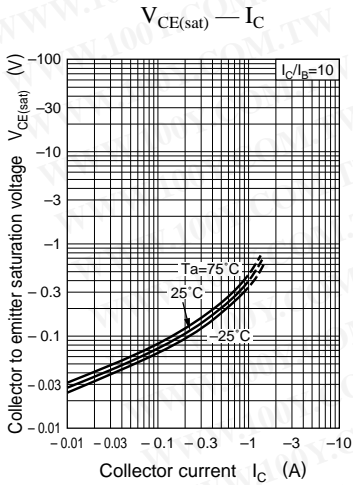
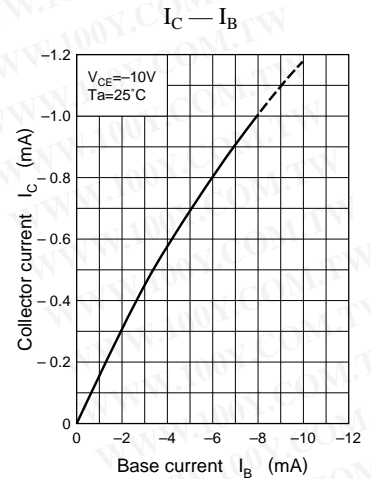
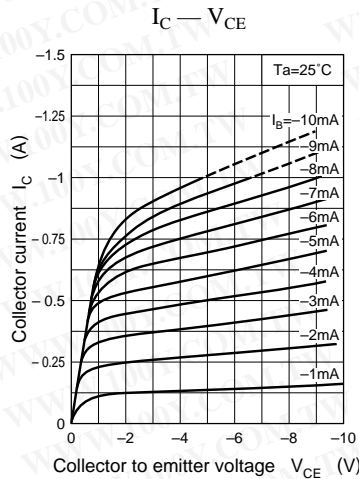
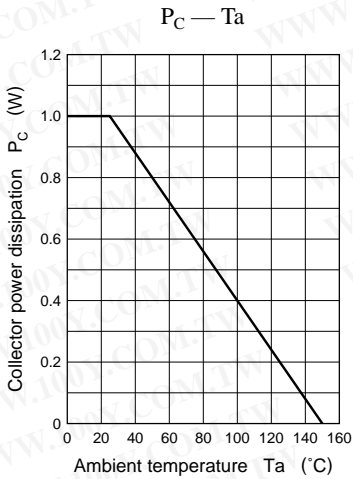

$I_{CEO} - T_a$

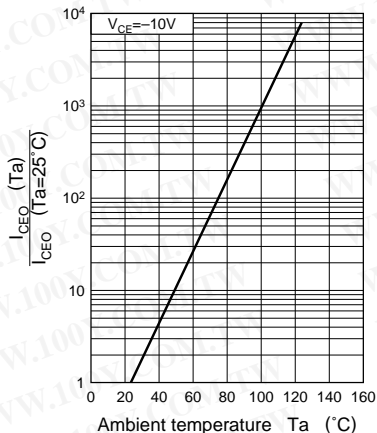

Area of safe operation (ASO)

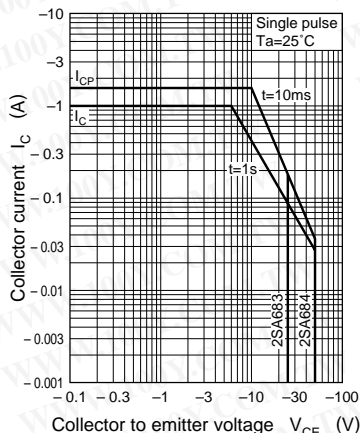

勝特力材料 886-3-5753170
勝特力电子(上海) 86-21-54151736
勝特力电子(深圳) 86-755-83298787
[Http://www.100y.com.tw](http://www.100y.com.tw)