

Transistors

Power Transistor (50V, 3A)

2SD1760 / 2SD1864

●Features

- 1) Low $V_{CE(sat)}$.
 $V_{CE(sat)} = 0.5V$ (Typ.)
 $(I_c/I_b = 2A / 0.2A)$
- 2) Complements the 2SB1184 / 2SB1243.

●Structure

Epitaxial planar type
 NPN silicon transistor

●External dimensions (Units : mm)

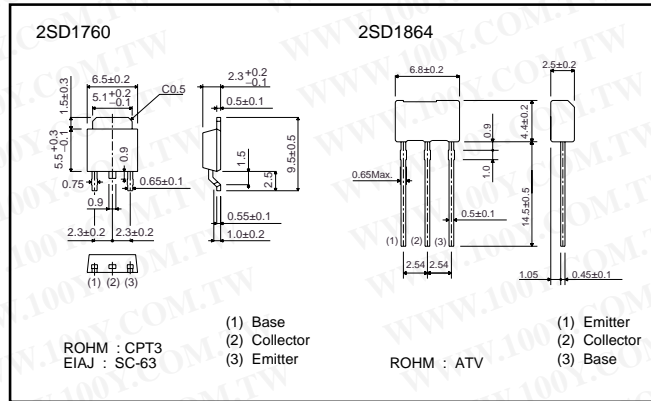

●Absolute maximum ratings ($T_a = 25^\circ C$)

Parameter	Symbol	Limits	Unit
Collector-base voltage	V_{CBO}	60	V
Collector-emitter voltage	V_{CEO}	50	V
Emitter-base voltage	V_{EBO}	5	V
Collector current	I_c	3	A (DC)
		4.5	A (Pulse) *1
Collector power dissipation	P_c	15	W ($T_c = 25^\circ C$)*2
		1	W
Junction temperature	T_j	150	$^\circ C$
Storage temperature	T_{stg}	-55~+150	$^\circ C$

*1 Single pulse, $P_w = 100ms$

*2 Printed circuit board, 1.7mm thick, collector copper plating 100mm² or larger.

Transistors

●Electrical characteristics (Ta = 25°C)

Parameter	Symbol	Min.	Typ.	Max.	Unit	Conditions
Collector-base breakdown voltage	BV _{CB0}	60	-	-	V	I _c = 50μA
Collector-emitter breakdown voltage	BV _{CE0}	50	-	-	V	I _c = 1mA
Emitter-base breakdown voltage	BV _{EB0}	5	-	-	V	I _E = 50μA
Collector cutoff current	I _{cBO}	-	-	1	μA	V _{CB} = 40V
Emitter cutoff current	I _{EBO}	-	-	1	μA	V _{EB} = 4V
Collector-emitter saturation voltage	V _{CE(sat)}	-	0.5	1	V	I _c /I _b = 2A/0.2A *
DC current transfer ratio	h _{FE}	82	-	390	-	V _{CE} = 3V, I _c = 0.5A *
Transition frequency	f _t	-	90	-	MHz	V _{CE} = 5V, I _E = -500mA, f = 30MHz *
Output capacitance	C _{ob}	-	40	-	pF	V _{CB} = 10V, I _E = 0A, f = 1MHz

* Measured using pulse current.

●Packaging specifications and h_{FE}

Type	h _{FE}	Package	Taping	
		Code	TL	TV2
		Basic ordering unit (pieces)	2500	2500
2SD1760	PQR		○	-
2SD1864	PQR		-	○

h_{FE} values are classified as follows:

Item	P	Q	R
h _{FE}	82~180	120~270	180~390

●Electrical characteristic curves

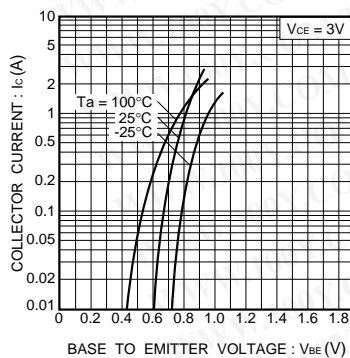

Fig.1 Grounded emitter propagation characteristics

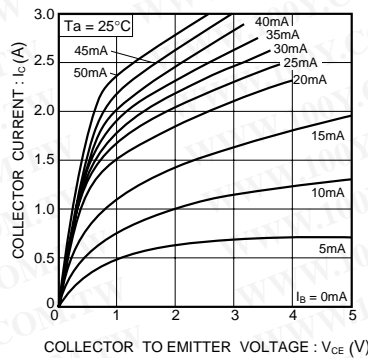

Fig.2 Grounded emitter output characteristics (I)

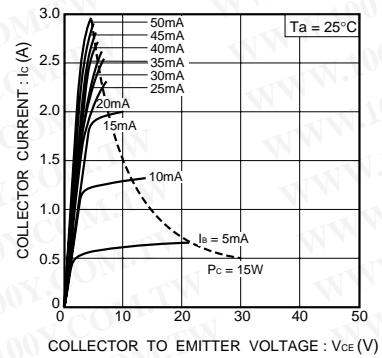

Fig.3 Grounded-emitter output characteristics(II)

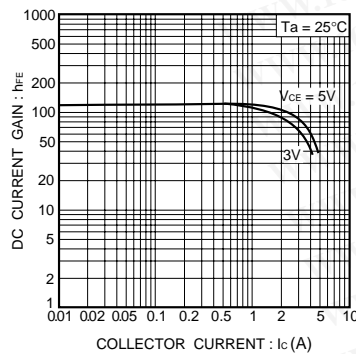

Fig.4 DC current gain vs. collector current(I)

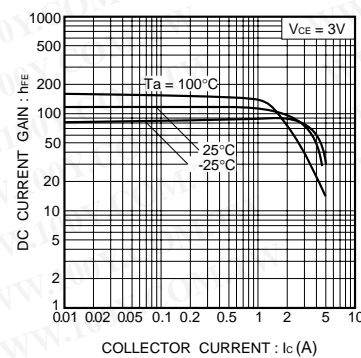

Fig.5 DC current gain vs. collector current(II)

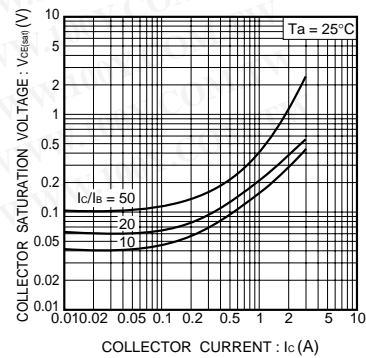

Fig.6 Collector-emitter saturation voltage vs. collector current

Transistors

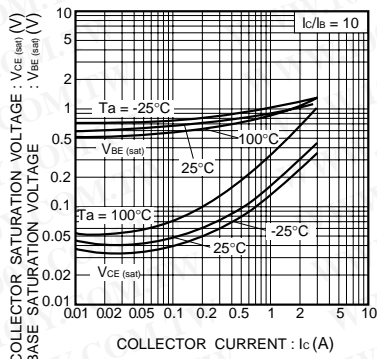

Fig.7 Collector-emitter saturation voltage vs. collector current
Base-emitter saturation voltage vs. collector current

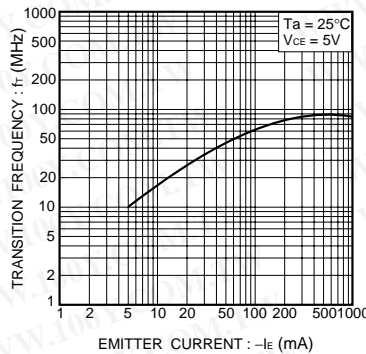

Fig.8 Gain bandwidth product vs. emitter current

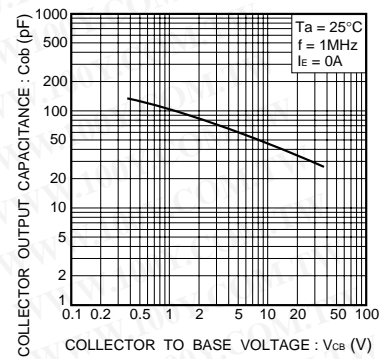

Fig.9 Collector output capacitance vs. collector-base voltage

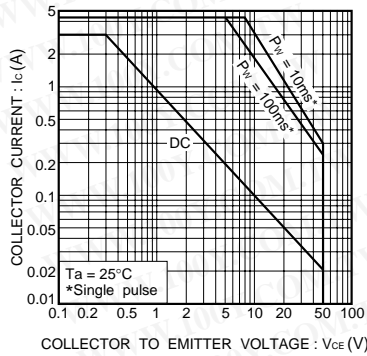

Fig.10 Safe operating area (2SD1760)

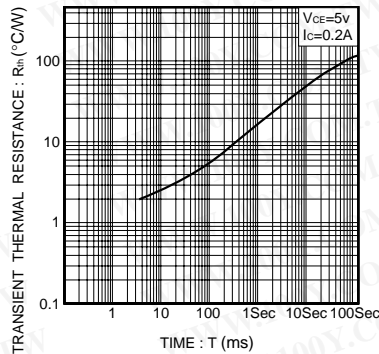

Fig.11 Transient thermal resistance (2SD1760)

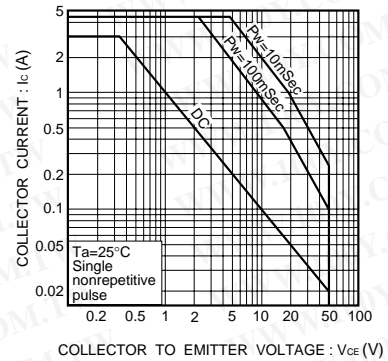

Fig.12 Safe operating area (2SD1864)

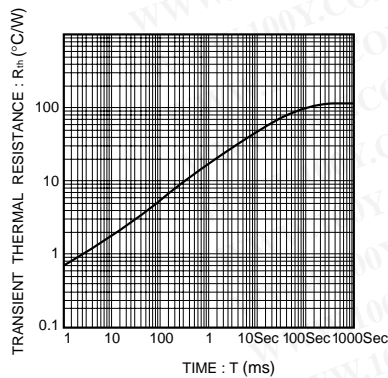

Fig.13 Transient thermal resistance (2SD1864)