



# Rectangular 10 Turn Dial (3 Digit), (4 Digit) 100 Turn



## FEATURES

- Rectangular digital scale
- 1" wide
- 1/4" or 1/8" or metric (6 mm) shaft adapter
- Open or clear plastic window bezel
- Black anodize finish with standard or white bezel trim
- Satin clear anodize finish
- Material categorization: For definitions of compliance please see [www.vishay.com/doc?99912](http://www.vishay.com/doc?99912)



RoHS  
COMPLIANT

QUICK REFERENCE DATA	
Sensor type	DIALS
Market appliance	Industrial
Dimensions	25.4 mm x 49.5 mm

MECHANICAL SPECIFICATIONS	
PARAMETER	
Numerals	The numerals shall be white on a black background and 0.130" H (3.30 cm)
Mounting	The spring detented knob shall be removed using a straight pull, exposing two no. 4 to 40 hex socket set screws for mounting the dial directly to the component shaft
Weight	1.6 oz. (45.36 g)

OPERATIONAL SPECIFICATIONS	
Operation 3 digit (10 turn) Left digit Right two digits	Complete revolutions of turning knob Percent of revolution The unit registers a total count of 999
Operation 4 digit (100 turn) Left two digits Right two digits	Complete revolutions of turning knob Percent of revolution The unit registers a total count of 9999
Rotation	The indication shall increase with clockwise rotation of the turning knob
Accuracy	Graduation lines adjacent to the numerals on the right digit wheel indicate settings 0.2 % of a revolution of the turning knob
Phasing	Dial phased by rotating the exposed component shaft to correspond with the desired reading on the dial prior to tightening the set screws

## DIMENSIONS in inches (millimeters)

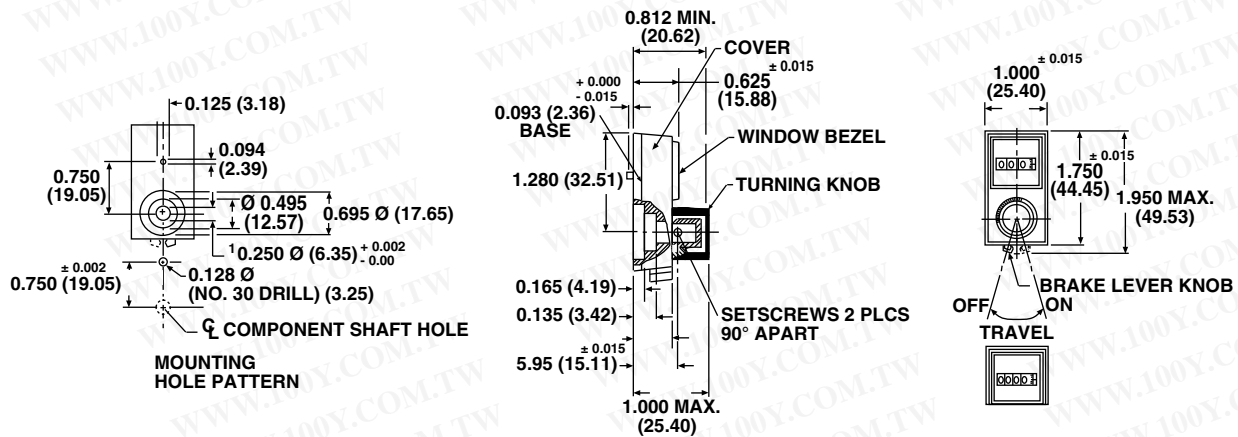

## ORDERING INFORMATION/DESCRIPTION

15	A	1	1	B010	e
MODEL	SHAFT DIAMETER AND NUMERICAL DISPLAY	BEZEL	FINISH	PACKAGING	LEAD FINISH
	A 1/4" dia. 3 digit B 1/4" dia. 4 digit C 1/8" dia. 3 digit D 1/8" dia. 4 digit E 6 mm dia. 3 digit F 6 mm dia. 4 digit	1. Open 3. Clear plastic window	1. Satin clear anodize 3. Black anodize, white bezel trim 5. Black anodize		
Example: 15 - A - 1 - 1					

## SAP PART NUMBERING GUIDELINES

15	A	1	1	B10
MODEL	SHAFT DIAMETER	BEZEL	FINISH	PACKAGING