



www.vishay.com

勝特力材料 886-3-5753170
勝特力电子(上海) 86-21-34970699
勝特力电子(深圳) 86-755-83298787
Http://www.100y.com.tw

WSL2726

Vishay Dale

Power Metal Strip® Resistors, Low Value, High Power, Surface Mount, 4-Terminal

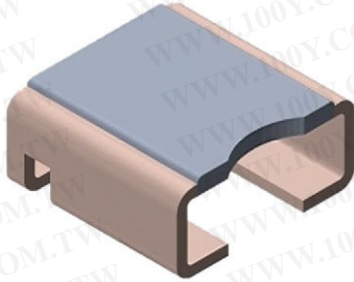

FEATURES

- 4-Terminal design allows for 1 % tolerance down to 0.0003 Ω
- High power to foot print size ratio
- Ideal for all types of current sensing, voltage division and pulse applications including switching and linear power supplies, instruments, power amplifiers and shunts
- Proprietary processing technique produces extremely low resistance values, down to 0.0003 Ω
- All welded construction of the Power Metal Strip® resistors are ideal for all types of current sensing, voltage division and pulse applications
- Solid metal nickel-chrome or manganese-copper alloy resistive element with low TCR (< 20 ppm/°C)
- Very low inductance 0.5 nH to 5 nH
- Low thermal EMF (< 3 μV/°C)
- AEC-Q200 qualified ⁽¹⁾
- Material categorization: for definitions of compliance please see www.vishay.com/doc?99912

AUTOMOTIVE GRADE



RoHS COMPLIANT
HALOGEN FREE
GREEN (5-2008)

DESIGN TOOLS (click logo to get started)



Notes

- Follow link to Overview of Automotive Grade Products for more details: www.vishay.com/doc?49924.
- ⁽¹⁾ Flame retardance test may not be applicable to some resistor technologies.

STANDARD ELECTRICAL SPECIFICATIONS

GLOBAL MODEL	SIZE	POWER RATING $P_{70^\circ\text{C}}$ W	TOLERANCE ± %	RESISTANCE VALUE RANGE Ω	RESISTANCE VALUES CURRENTLY AVAILABLE ⁽¹⁾ Ω	WEIGHT (typical) g/1000 pieces
WSL2726	2726	3.0	1.0	0.3m to 5m	0.3m, 0.5m, 0.7m, 1m, 2m, 3m, 4m, 5m	420

Notes

- Power rating depends on the max. temperature at the solder point, component placement density and the substrate material.
- Part marking: Model, value, tolerance, date code.
- ⁽¹⁾ Other values may be available, contact factory.

GLOBAL PART NUMBER INFORMATION

Global Part Numbering example: WSL2726L5000FEA (visit www.vishay.net Vishay Dale parts numbering manual for all options)

W S L 2 7 2 6 L 5 0 0 0 F E A

GLOBAL MODEL	RESISTANCE VALUE	TOLERANCE CODE	PACKAGING CODE ⁽¹⁾	SPECIAL
WSL2726	L = mΩ L3000 = 0.0003 Ω L5000 = 0.0005 Ω L7000 = 0.0007 Ω 1L000 = 0.0010 Ω 2L000 = 0.0020 Ω 3L000 = 0.0030 Ω 4L000 = 0.0040 Ω 5L000 = 0.0050 Ω	F = ± 1.0 %	EA = lead (Pb)-free, tape/reel EK = lead (Pb)-free, bulk	(dash number) (up to 2 digits) from 1 to 99 as applicable

Note

- ⁽¹⁾ Packaging code: EB (lead (Pb)-free) and TB (tin / lead) are non-standard packaging codes designating 1000 piece reels. These non-standard packaging codes are identical to our standard EA (lead (Pb)-free) and TA (tin / lead), except that they have a package quantity of 1000 pieces.

TECHNICAL SPECIFICATIONS		
PARAMETER	UNIT	RESISTOR CHARACTERISTICS
Component temperature coefficient (including terminal) ⁽¹⁾	ppm/°C	± 75 for 0.5 mΩ to 5 mΩ, ± 110 for 0.3 mΩ
Element TCR ⁽²⁾	ppm/°C	< 20
Operating temperature range	°C	-65 to +170
Maximum working voltage ⁽³⁾	V	$(P \times R)^{1/2}$

Notes

- (1) Component TCR - total TCR that includes the TCR effects of the resistor element and the copper terminal.
- (2) Element TCR - only applies to the alloy used for the resistor element; refer to item 1 in the construction illustration on the following page.
- (3) Maximum working voltage - the WSL is not voltage sensitive, but is limited by power / energy dissipation and is also not ESD sensitive.

DIMENSIONS in inches (millimeters)

MODEL	DIMENSIONS							
	L	W	H	R (REF.)	S	T	U	N
WSL2726	0.272 ± 0.008 (6.9 ± 0.2)	0.260 ± 0.012/- 0.008 (6.6 ± 0.3/- 0.2)	Please see table below	0.195 (5.0)	0.028 ± 0.004 (0.7 ± 0.1)	0.016 ± 0.002 (0.4 ± 0.05)	0.078 ± 0.004 (2.0 ± 0.1)	0.039 ± 0.006 (0.99 ± 0.15)

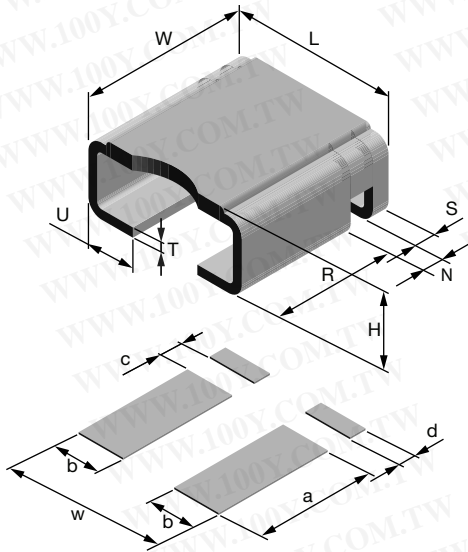

MODEL	SOLDER PAD DIMENSIONS				
	a	b	c	d	w
WSL2726	0.220 (5.6)	0.096 (2.44)	0.035 (0.89)	0.035 (0.89)	0.290 (7.4)

MODEL	RESISTANCE VALUE (mΩ)	ELEMENT MATERIAL	HEIGHT H
WSL2726	0.3	Mn-Cu	0.141 ± 0.008 (3.58 ± 0.2)
	0.5	Mn-Cu	0.116 ± 0.008 (2.95 ± 0.2)
	0.7	Mn-Cu	0.111 ± 0.008 (2.82 ± 0.2)
	1.0	Mn-Cu	0.1055 ± 0.008 (2.68 ± 0.2)
	2.0	Ni-Cr	0.114 ± 0.008 (2.9 ± 0.2)
	3.0	Ni-Cr	0.110 ± 0.008 (2.79 ± 0.2)
	4.0	Ni-Cr	0.110 ± 0.008 (2.79 ± 0.2)
	5.0	Ni-Cr	0.110 ± 0.008 (2.79 ± 0.2)

Notes

- 3D models available: www.vishay.com/doc?30308.
- Surface mount solder profile recommendations: www.vishay.com/doc?31052.



DERATING - AMBIENT TEMPERATURE

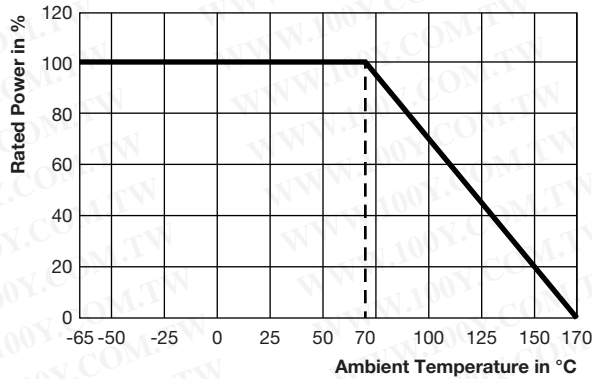

DERATING - TERMINAL TEMPERATURE

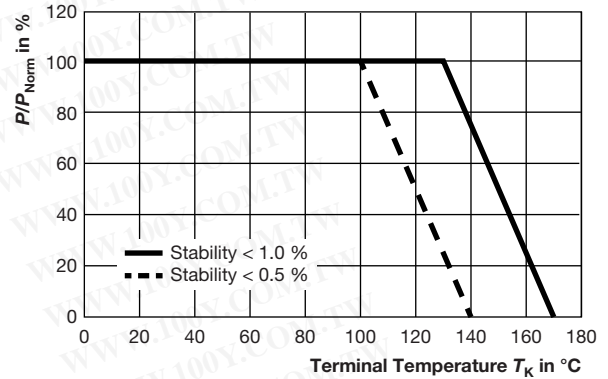

Example: WSL2726 0.0005 Ω , 0.001 Ω

PERFORMANCE		
TEST	CONDITIONS OF TEST	TEST LIMITS
Thermal shock	-55 °C to +150 °C, 1000 cycles, 15 min at each extreme	± 0.5 %
Short time overload	0.3 m Ω , 0.5 m Ω , 2 m Ω and 3 m Ω - 5x rated power for 5 s 4 m Ω and 5 m Ω - 3x rated power for 5 s	± 0.5 %
Low temperature operation	-65 °C for 45 min	± 0.5 %
High temperature exposure	1000 h at +170 °C	± 1.0 %
Bias humidity	+85 °C, 85 % RH, 10 % bias, 1000 h	± 0.5 %
Mechanical shock	100 g's for 6 ms, 5 pulses	± 0.5 %
Vibration	Frequency varied 10 Hz to 2000 Hz in 1 min, 3 directions, 12 h	± 0.5 %
Load life	1000 h at +70 °C, 1.5 h "ON", 0.5 h "OFF"	± 1.0 %
Resistance to solder heat	+260 °C solder, 10 s to 12 s dwell, 25 mm/s emergence	± 0.5 %
Moisture resistance	MIL-STD-202, method 106, 0 % power, 7b not required	± 0.5 %

PACKAGING (1)				
MODEL	REEL			
	TAPE WIDTH	DIAMETER	PIECES/REEL	CODE
WSL2726	16 mm/embossed plastic	330 mm/13"	1500	EA

Notes

- Embossed carrier tape per EIA-481.
- (1) Additional packaging details at www.vishay.com/doc?20051.