

# DATA SHEET

GENERAL PURPOSE CHIP RESISTORS

RC2010

5%, 1%

RoHS compliant

勝特力材料 886-3-5753170  
勝特力电子(上海) 86-21-34970699  
勝特力电子(深圳) 86-755-83298787  
[Http://www.100y.com.tw](http://www.100y.com.tw)



**SCOPE**

This specification describes RC2010 series chip resistors with lead-free terminations made by thick film process.

**APPLICATIONS**

- All general purpose application

**FEATURES**

- Halogen Free Epoxy
- RoHS compliant
  - Products with lead free terminations meet RoHS requirements
  - Pb-glass contained in electrodes, resistor element and glass are exempted by RoHS
- Reducing environmentally hazardous wastes
- High component and equipment reliability
- Saving of PCB space
- None forbidden-materials used in products/production

**ORDERING INFORMATION - GLOBAL PART NUMBER & I2NC**

Both part numbers are identified by the series, size, tolerance, packing type, temperature coefficient, taping reel and resistance value.

**YAGEO BRAND ordering code**

**GLOBAL PART NUMBER (PREFERRED)**

**RC2010 X K - XX XXXX L**  
 (1) (2) (3) (4) (5) (6)

**(1) TOLERANCE**

F = ±1%  
 J = ±5% (for Jumper ordering, use code of J)

**(2) PACKAGING TYPE**

K = Embossed taping reel

**(3) TEMPERATURE COEFFICIENT OF RESISTANCE**

- = Base on spec

**(4) TAPING REEL**

07 = 7 inch dia. Reel

**(5) RESISTANCE VALUE**

There are 2~4 digits indicated the resistor value. Letter R/K/M is decimal point, no need to mention the last zero after R/K/M, e.g. 1K2, not 1K20.  
 Detailed resistance rules show in table of "Resistance rule of global part number".

**(6) DEFAULT CODE**

Letter L is system default code for order only (Note)

**勝特力材料 886-3-5753170**  
**勝特力电子(上海) 86-21-34970699**  
**勝特力电子(深圳) 86-755-83298787**  
[Http://www.100y.com.tw](http://www.100y.com.tw)

**Resistance rule of global part number**

Resistance code rule	Example
OR	OR = Jumper
XRX	1R = 1 Ω
(1 to 9.76 Ω)	1R5 = 1.5 Ω
	9R76 = 9.76 Ω
XXRX	10R = 10 Ω
(10 to 97.6 Ω)	97R6 = 97.6 Ω
XXXR	100R = 100 Ω
(100 to 976 Ω)	
XKXX	1K = 1,000 Ω
(1 to 9.76 KΩ)	9K76 = 9760 Ω
XMXX	1M = 1,000,000 Ω
(1 to 9.76 MΩ)	9M76 = 9,760,000 Ω

**ORDERING EXAMPLE**

The ordering code of a RC2010 chip resistor, value 56 Ω with ±1% tolerance, supplied in 7-inch tape reel is: RC2010FK-0756RL.

**NOTE**

1. All our RSMD products meet RoHS compliant and Halogen Free. "LFP" of the internal 2D reel label mentions "Lead Free Process"
2. On customized label, "LFP" or specific symbol can be printed

勝特力材料 886-3-5753170  
 勝特力电子(上海) 86-21-34970699  
 勝特力电子(深圳) 86-755-83298787  
[Http://www.100y.com.tw](http://www.100y.com.tw)

**PHYCOMP BRAND ordering codes**

Both GLOBAL PART NUMBER (preferred) and I2NC (traditional) codes are acceptable to order Phycomp brand products.

**GLOBAL PART NUMBER (PREFERRED)**

For detailed information of GLOBAL PART NUMBER and ordering example, please refer to page 2.

**I2NC CODE**

	<b>2322</b>	<b>XXX XXXXX L</b>			
	(1)	(2)	(3)	(4)	
TYPE/ 2010	START IN <sup>(1)</sup>	TOL. (%)	RESISTANCE RANGE	EMBOSSED TAPE ON REEL (units) <sup>(2)</sup>	
				4,000	
PRCIII	2322	±5%	1 to 22 MΩ	760 60xxx	
PRCIII	2322	±1%	1 to 10 MΩ	761 6xxxx	
Jumper	2322	-	0 Ω	760 90003	

Resistance decade <sup>(3)</sup>	Last digit
0.01 to 0.0976 Ω	0
0.1 to 0.976 Ω	7
1 to 9.76 Ω	8
10 to 97.6 Ω	9
100 to 976 Ω	1
1 to 9.76 KΩ	2
10 to 97.6 KΩ	3
100 to 976 KΩ	4
1 to 9.76 MΩ	5
10 to 97.6 MΩ	6

- (1) The resistors have a 12-digit ordering code starting with 2322.
- (2) The subsequent 4 or 5 digits indicate the resistor tolerance and packaging.
- (3) The remaining 4 or 3 digits represent the resistance value with the last digit indicating the multiplier as shown in the table of "Last digit of I2NC".
- (4) Letter L is system default code for order only <sup>(Note)</sup>

Example:

0.02 Ω	=	0200 or 200
0.3 Ω	=	3007 or 307
1 Ω	=	1008 or 108
33 KΩ	=	3303 or 333
10 MΩ	=	1006 or 106

**ORDERING EXAMPLE**

The ordering code of a PRCIII resistor, value 56 Ω with ±1% tolerance, supplied in tape of 4,000 units per reel is: 232276165609L or RC2010FK-0756RL.

**NOTE**

- 1. All our RSMD products meet RoHS compliant and Halogen Free. "LFP" of the internal 2D reel label mentions "Lead Free Process"
- 2. On customized label, "LFP" or specific symbol can be printed

勝特力材料 886-3-5753170  
 勝特力电子(上海) 86-21-34970699  
 勝特力电子(深圳) 86-755-83298787  
[Http://www.100y.com.tw](http://www.100y.com.tw)

**MARKING**

RC2010



E-24 series: 3 digits  
 First two digits for significant figure and 3rd digit for number of zeros

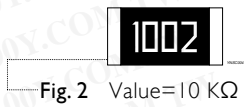

Both E-24 and E-96 series: 4 digits  
 First three digits for significant figure and 4th digit for number of zeros

For further marking information, please see special data sheet "Chip resistors marking".

**CONSTRUCTION**

The resistor is constructed on top of a high-grade ceramic body. Internal metal electrodes are added on each end to make the contacts to the thick film resistive element. The composition of the resistive element is a noble metal imbedded into a glass and covered by a second glass to prevent environment influences. The resistor is laser trimmed to the rated resistance value. The resistor is covered with a protective epoxy coat, finally the two external terminations (matte tin on Ni-barrier) are added. See fig.3

**OUTLINES**

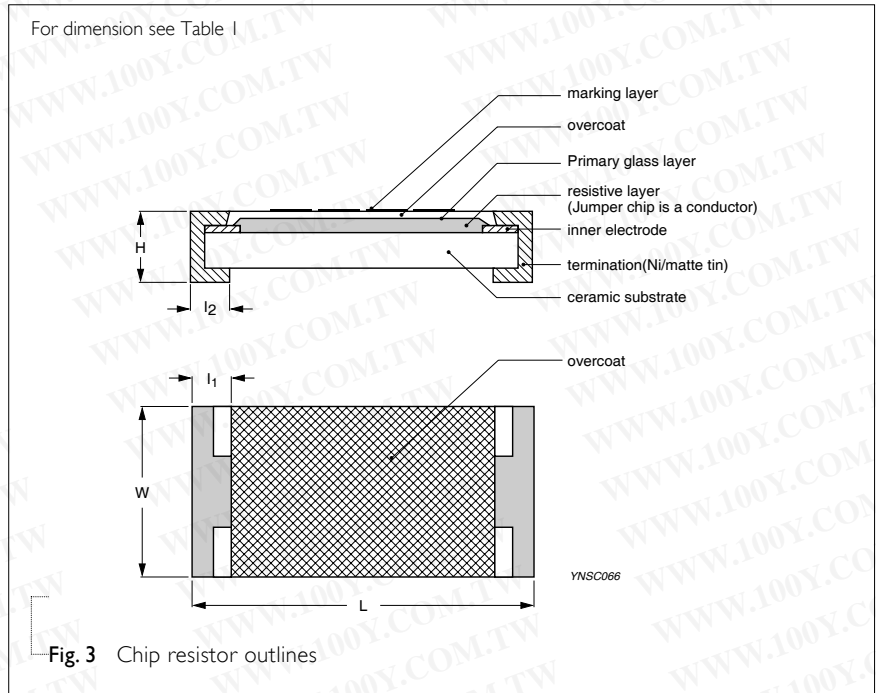

**DIMENSIONS**

Table I	
TYPE	RC2010
L (mm)	5.00 ± 0.10
W (mm)	2.50 ± 0.15
H (mm)	0.55 ± 0.10
l <sub>1</sub> (mm)	0.45 ± 0.15
l <sub>2</sub> (mm)	0.50 ± 0.20

**ELECTRICAL CHARACTERISTICS**

Table 2

CHARACTERISTICS	RC2010 3/4 W	
Operating Temperature Range	-55 °C to +155 °C	
Maximum Working Voltage	200 V	
Maximum Overload Voltage	500 V	
Dielectric Withstanding Voltage	500 V	
Resistance Range	5% (E24)	1 Ω to 22 MΩ
	1% (E24/E96)	1 Ω to 10 MΩ
	Zero Ohm Jumper	< 0.05 Ω
Temperature Coefficient	1 Ω ≤ R ≤ 10 Ω	±200 ppm/°C
	10 MΩ ≤ R ≤ 22 MΩ	±200 ppm/°C
	10 Ω < R ≤ 10 MΩ	±100 ppm/°C
Jumper Criteria	Rated Current	2 A
	Maximum Current	10 A

**FOOTPRINT AND SOLDERING PROFILES**

For recommended footprint and soldering profiles, please see the special data sheet “Chip resistors mounting”.

勝特力材料 886-3-5753170  
 胜特力电子(上海) 86-21-34970699  
 胜特力电子(深圳) 86-755-83298787  
[Http://www.100y.com.tw](http://www.100y.com.tw)

**PACKING STYLE AND PACKAGING QUANTITY**

Table 3 Packing style and packaging quantity

PRODUCT TYPE	PACKING STYLE	REEL DIMENSION	QUANTITY PER REEL
RC2010	Embossed taping reel (K)	7" (178 mm)	4,000 units

**NOTE**

I. For embossed tape and reel specification/dimensions, please see the special data sheet “Packing” document.

**FUNCTIONAL DESCRIPTION**

**POWER RATING**

RC2010 rated power at 70°C is 3/4 W

**RATED VOLTAGE**

The DC or AC (rms) continuous working voltage corresponding to the rated power is determined by the following formula:

$$V = \sqrt{P \times R}$$

or max. working voltage whichever is less

Where

V=Continuous rated DC or AC (rms) working voltage (V)

P=Rated power (W)

R=Resistance value (Ω)

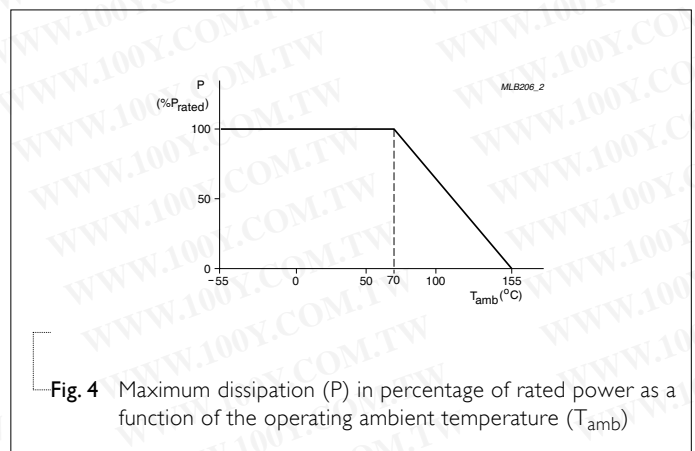

Fig. 4 Maximum dissipation (P) in percentage of rated power as a function of the operating ambient temperature (T<sub>amb</sub>)

**TESTS AND REQUIREMENTS**

**Table 4** Test condition, procedure and requirements

TEST	TEST METHOD	PROCEDURE	REQUIREMENTS
Temperature Coefficient of Resistance (T.C.R.)	IEC 60115-1 4.8	At +25/-55 °C and +25/+125 °C  Formula: $T.C.R = \frac{R_2 - R_1}{R_1(t_2 - t_1)} \times 10^6 \text{ (ppm/°C)}$ Where t <sub>1</sub> =+25 °C or specified room temperature t <sub>2</sub> =-55 °C or +125 °C test temperature R <sub>1</sub> =resistance at reference temperature in ohms R <sub>2</sub> =resistance at test temperature in ohms	Refer to table 2
Life/Endurance	IEC 60115-1 4.25.1	At 70±5 °C for 1,000 hours, RCWV applied for 1.5 hours on, 0.5 hour off, still air required	±(1.0%+0.05 Ω) for 1% tol. ±(3.0%+0.05 Ω) for 5% tol. <100 mΩ for Jumper
High Temperature Exposure/Endurance at Upper Category Temperature	IEC 60068-2-2	1,000 hours at 155±5 °C, unpowered	±(1.0%+0.05 Ω) for 1% tol. ±(2.0%+0.05 Ω) for 5% tol. <50 mΩ for Jumper
Moisture Resistance	MIL-STD-202G Method-106G	Each temperature / humidity cycle is defined at 8 hours, 3 cycles / 24 hours for 10d. with 25 °C / 65 °C 95% R.H, without steps 7a & 7b, unpowered  Parts mounted on test-boards, without condensation on parts  Measurement at 24±2 hours after test conclusion	±(0.5%+0.05 Ω) for 1% tol. ±(2.0%+0.05 Ω) for 5% tol. <100 mΩ for Jumper
Thermal Shock	MIL-STD-202G Method-107G	-55/+125 °C  Number of cycles required is 300. Devices unmounted  Maximum transfer time is 20 seconds. Dwell time is 15 minutes. Air – Air	±(0.5%+0.05 Ω) for 1% tol. ±(1%+0.05 Ω) for 5% tol. <50 mΩ for Jumper
Short Time Overload	IEC60115-1 4.13	2.5 times of rated voltage or maximum overload voltage whichever is less for 5 sec at room temperature	±(1.0%+0.05 Ω) for 1% tol. ±(2.0%+0.05 Ω) for 5% tol. <50 mΩ for Jumper No visible damage

**勝特力材料 886-3-5753170**  
**勝特力电子(上海) 86-21-34970699**  
**勝特力电子(深圳) 86-755-83298787**  
[Http://www.100y.com.tw](http://www.100y.com.tw)

TEST	TEST METHOD	PROCEDURE	REQUIREMENTS														
Board Flex/ Bending	IEC 60068-2-21	Chips mounted on a 90mm glass epoxy resin PCB (FR4) 2 mm bending Bending time: 60±5 seconds	±(1.0%+0.05 Ω) for 1%, 5% tol. <50 mΩ for Jumper No visible damage														
Low Temperature Operation	IEC 60068-2-1	The resistor shall be subjected to a DC rated voltage for 1.5 h-on, 0.5 h-off, at -55±3 °C This constitutes shall be repeated for 96 hours However the applied voltage shall not exceed the maximum operating voltage	±(0.5%+0.05 Ω) for 1% tol. ±(1.0%+0.05 Ω) for 5% tol. No visible damage														
Insulation Resistance	IEC 60115-1 4.6	Rated continuous overload voltage (RCOV) for 1 minute  <b>Type</b> <b>RC2010</b> <b>Voltage (DC)</b> 100 V	≥10 GΩ														
Dielectric Withstand Voltage	IEC 60115-1 4.7	Maximum voltage (V <sub>rms</sub> ) applied for 1 minute  <b>Type</b> <b>RC2010</b> <b>Voltage (AC)</b> 500 V <sub>rms</sub>	No breakdown or flashover														
Resistance to Solvent	IPC/JEDEC J-STD-020D	Isopropylalcohol (C <sub>3</sub> H <sub>7</sub> OH) followed by brushing	No smeared														
Noise	IEC 60115-1 4.12	Maximum voltage (V <sub>rms</sub> ) applied	<table border="1"> <thead> <tr> <th>Resistors range</th> <th>Value</th> </tr> </thead> <tbody> <tr> <td>R &lt; 100 Ω</td> <td>10 dB</td> </tr> <tr> <td>100 Ω ≤ R &lt; 1 KΩ</td> <td>20 dB</td> </tr> <tr> <td>1 KΩ ≤ R &lt; 10 KΩ</td> <td>30 dB</td> </tr> <tr> <td>10 KΩ ≤ R &lt; 100 KΩ</td> <td>40 dB</td> </tr> <tr> <td>100 KΩ ≤ R &lt; 1 MΩ</td> <td>46 dB</td> </tr> <tr> <td>1 MΩ ≤ R ≤ 22 MΩ</td> <td>48 dB</td> </tr> </tbody> </table>	Resistors range	Value	R < 100 Ω	10 dB	100 Ω ≤ R < 1 KΩ	20 dB	1 KΩ ≤ R < 10 KΩ	30 dB	10 KΩ ≤ R < 100 KΩ	40 dB	100 KΩ ≤ R < 1 MΩ	46 dB	1 MΩ ≤ R ≤ 22 MΩ	48 dB
Resistors range	Value																
R < 100 Ω	10 dB																
100 Ω ≤ R < 1 KΩ	20 dB																
1 KΩ ≤ R < 10 KΩ	30 dB																
10 KΩ ≤ R < 100 KΩ	40 dB																
100 KΩ ≤ R < 1 MΩ	46 dB																
1 MΩ ≤ R ≤ 22 MΩ	48 dB																
Biased Humidity (steady state)	IEC 60115-1 4.37	Steady state for 1000 hours at 40 °C / 95% R.H. RCWV applied for 1.5 hours on and 0.5 hour off	±(1.0%+0.05 Ω) for 1% tol. ±(2.0%+0.05 Ω) for 5% tol. <100 mΩ for Jumper														

TEST	TEST METHOD	PROCEDURE	REQUIREMENTS
Intermittent Overload	IEC 60115-1 4.39	2.5 times of rated voltage or maximum overload voltage whichever is less for 1 second on and 25 seconds off; total 10,000 cycles	±(1.0%+0.05 Ω) for 1% tol. ±(2.0%+0.05 Ω) for 5% tol. <100 mΩ for Jumper
Solderability - Wetting	IPC/JEDEC J-STD-002B test B	Electrical Test not required Magnification 50X SMD conditions: 1 <sup>st</sup> step: method B, aging 4 hours at 155 °C dry heat 2 <sup>nd</sup> step: leadfree solder bath at 245±3 °C Dipping time: 3±0.5 seconds	Well tinned (≥95% covered) No visible damage
- Leaching	IPC/JEDEC J-STD-002B test D	Leadfree solder, 260 °C, 30 seconds immersion time	No visible damage
- Resistance to Soldering Heat	IEC 60068-2-58	Condition B, no pre-heat of samples Leadfree solder, 260 °C, 10 seconds immersion time Procedure 2 for SMD: devices fluxed and cleaned with isopropanol	±(0.5%+0.05 Ω) for 1% tol. ±(1.0%+0.05 Ω) for 5% tol. <50 mΩ for Jumper No visible damage



勝特力材料 886-3-5753170  
 勝特力电子(上海) 86-21-34970699  
 勝特力电子(深圳) 86-755-83298787  
[Http://www.100y.com.tw](http://www.100y.com.tw)

**REVISION HISTORY**

REVISION	DATE	CHANGE NOTIFICATION	DESCRIPTION
Version 4	Sep 22, 2009	-	<ul style="list-style-type: none"> <li>- Test Items and methods updated</li> <li>- Test requirements upgraded</li> </ul>
Version 3	Jul 15, 2008	-	<ul style="list-style-type: none"> <li>- Change to dual brand datasheet that describe RC2010 with RoHS compliant</li> <li>- Description of "Halogen Free Epoxy" added</li> <li>- Define global part number</li> </ul>
Version 2	Sep 16, 2004	-	<ul style="list-style-type: none"> <li>- New datasheet for 2010 thick film 1% and 5% with lead-free terminations</li> <li>- Replace the 2010 part of pdf files: PRC111_1_5, PRC111_5_6</li> <li>- Test method and procedure updated</li> </ul>

*“Yageo reserves all the rights for revising the content of this datasheet without further notification, as long as the products itself are unchanged. Any product change will be announced by PCN.”*