

CMPD4448
SURFACE MOUNT
HIGH SPEED
SILICON SWITCHING DIODE

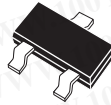

SOT-23 CASE

CentralTM

Semiconductor Corp.

DESCRIPTION:

The CENTRAL SEMICONDUCTOR CMPD4448 type is an ultra-high speed silicon switching diode manufactured by the epitaxial planar process, in an epoxy molded surface mount package, designed for high speed switching applications.

MARKING CODE: AAD

MAXIMUM RATINGS: ($T_A=25^{\circ}\text{C}$)

	SYMBOL		UNITS
Continuous Reverse Voltage	V_R	75	V
Peak Repetitive Reverse Voltage	V_{RRM}	100	V
Continuous Forward Current	I_F	250	mA
Peak Repetitive Forward Current	I_{FRM}	500	mA
Forward Surge Current, $t_p=1$ ms	I_{FSM}	4.0	A
Forward Surge Current, $t_p=1$ s	I_{FSM}	1.0	A
Power Dissipation	P_D	350	mW
Operating and Storage Junction Temperature	T_J, T_{stg}	-65 to +150	$^{\circ}\text{C}$
Thermal Resistance	θ_{JA}	357	$^{\circ}\text{C/W}$

ELECTRICAL CHARACTERISTICS: ($T_A=25^{\circ}\text{C}$ unless otherwise noted)

SYMBOL	TEST CONDITIONS	MIN	MAX	UNITS
BV_R	$I_R=5.0\mu\text{A}$	75		V
BV_R	$I_R=100\mu\text{A}$	100		V
I_R	$V_R=20\text{V}$		25	nA
V_F	$I_F=5.0\text{mA}$	0.62	0.72	V
V_F	$I_F=100\text{mA}$		1.0	V
C_T	$V_R=0, f=1.0\text{MHz}$		4.0	pF
t_{rr}	$I_R=I_F=10\text{mA}, R_L=100\Omega, \text{Rec. to } 1.0\text{mA}$		4.0	ns

勝特力材料 886-3-5753170
勝特力电子(上海) 86-21-54151736
勝特力电子(深圳) 86-755-83298787
[Http://www.100y.com.tw](http://www.100y.com.tw)

SOT-23 CASE - MECHANICAL OUTLINE

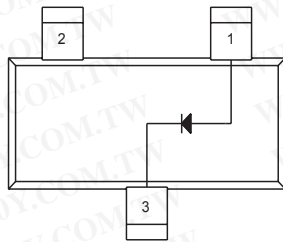
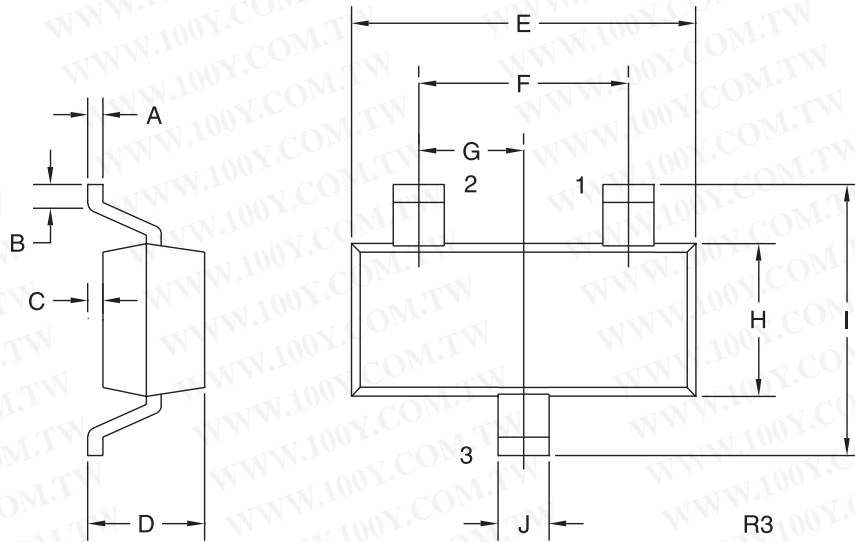

LEAD CODE:

- 1) ANODE
- 2) NO CONNECTION
- 3) CATHODE

MARKING CODE: AAD

SYMBOL	INCHES		MILLIMETERS	
	MIN	MAX	MIN	MAX
A	0.003	0.007	0.08	0.18
B	0.006	-	0.15	-
C	-	0.005	-	0.13
D	0.035	0.043	0.89	1.09
E	0.110	0.120	2.80	3.05
F	0.075		1.90	
G	0.037		0.95	
H	0.047	0.055	1.19	1.40
I	0.083	0.098	2.10	2.49
J	0.014	0.020	0.35	0.50

SOT-23 (REV: R3)

勝特力材料 886-3-5753170
 勝特力电子(上海) 86-21-54151736
 勝特力电子(深圳) 86-755-83298787
[Http://www.100y.com.tw](http://www.100y.com.tw)

R6 (2-December 2003)