

International
IR Rectifier

PD-95967

IRGPS40B120UDP

INSULATED GATE BIPOLAR TRANSISTOR WITH
 ULTRAFast SOFT RECOVERY DIODE

UltraFast Co-Pack IGBT

Features

- Non Punch Through IGBT Technology.
- Low Diode VF.
- 10µs Short Circuit Capability.
- Square RBSOA.
- Ultrasoft Diode Reverse Recovery Characteristics.
- Positive VCE (on) Temperature Coefficient.
- Super-247 Package.
- Lead-Free

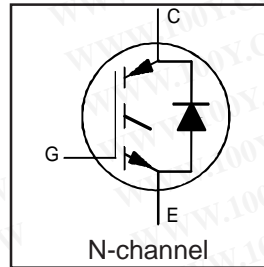

$V_{CES} = 1200V$
$V_{CE(on)} \text{ typ.} = 3.12V$
@ $V_{GE} = 15V,$
$I_{CE} = 40A, T_j = 25^\circ C$

Benefits

- Benchmark Efficiency for Motor Control.
- Rugged Transient Performance.
- Low EMI.
- Significantly Less Snubber Required
- Excellent Current Sharing in Parallel Operation.



Absolute Maximum Ratings

	Parameter	Max.	Units
V_{CES}	Collector-to-Emitter Voltage	1200	V
$I_C @ T_C = 25^\circ C$	Continuous Collector Current	80	A
$I_C @ T_C = 100^\circ C$	Continuous Collector Current	40	
I_{CM}	Pulsed Collector Current	160	
I_{LM}	Clamped Inductive Load Current $\text{\textcircled{D}}$	160	
$I_F @ T_C = 25^\circ C$	Diode Continuous Forward Current	80	
$I_F @ T_C = 100^\circ C$	Diode Continuous Forward Current	40	
I_{FM}	Diode Maximum Forward Current	160	V
V_{GE}	Gate-to-Emitter Voltage	± 20	
$P_D @ T_C = 25^\circ C$	Maximum Power Dissipation	595	W
$P_D @ T_C = 100^\circ C$	Maximum Power Dissipation	238	
T_J	Operating Junction and	-55 to +150	$^\circ C$
T_{STG}	Storage Temperature Range		
	Soldering Temperature, for 10 sec.	300 (0.063 in. (1.6mm) from case)	

Thermal Resistance

	Parameter	Min.	Typ.	Max.	Units
$R_{\theta JC}$	Junction-to-Case - IGBT	—	—	0.20	$^\circ C/W$
$R_{\theta JC}$	Junction-to-Case - Diode	—	—	0.83	
$R_{\theta CS}$	Case-to-Sink, flat, greased surface	—	0.24	—	
$R_{\theta JA}$	Junction-to-Ambient, typical socket mount	—	—	40	
	Recommended Clip Force	20 (2)	—	—	N(kgf)
Wt	Weight	—	6.0 (0.21)	—	g (oz)
Le	Internal Emitter Inductance (5mm from package)	—	13	—	nH

IRGPS40B120UDP

International
IRF Rectifier

Electrical Characteristics @ T_J = 25°C (unless otherwise specified)

	Parameter	Min.	Typ.	Max.	Units	Conditions	Ref.Fig.
V _{(BR)CES}	Collector-to-Emitter Breakdown Voltage	1200	—	—	V	V _{GE} = 0V, I _C = 500μA	
ΔV _{(BR)CES} /ΔT _J	Temperature Coeff. of Breakdown Voltage	—	0.40	—	V/°C	V _{GE} = 0V, I _C = 1.0mA, (25°C-125°C)	
V _{CE(on)}	Collector-to-Emitter Saturation Voltage	—	3.12	3.40	V	I _C = 40A I _C = 50A I _C = 40A, T _J = 125°C I _C = 50A, T _J = 125°C	5, 6
		—	3.39	3.70			7, 9
		—	3.88	4.30			10
		—	4.24	4.70			11
V _{GE(th)}	Gate Threshold Voltage	4.0	5.0	6.0		V _{CE} = V _{GE} , I _C = 250μA	9,10
ΔV _{GE(th)} /ΔT _J	Temperature Coeff. of Threshold Voltage	—	-12	—	mV/°C	V _{CE} = V _{GE} , I _C = 1.0mA, (25°C-125°C)	11, 12
g _{fe}	Forward Transconductance	—	30.5	—	S	V _{CE} = 50V, I _C = 40A, PW=80μs	
I _{CES}	Zero Gate Voltage Collector Current	—	—	500	μA	V _{GE} = 0V, V _{CE} = 1200V	
		—	420	1200		V _{GE} = 0V, V _{CE} = 1200V, T _J = 125°C	
V _{FM}	Diode Forward Voltage Drop	—	2.03	2.40	V	I _C = 40A	8
		—	2.17	2.60		I _C = 50A	
		—	2.26	2.68		I _C = 40A, T _J = 125°C	
		—	2.46	2.95		I _C = 50A, T _J = 125°C	
I _{GES}	Gate-to-Emitter Leakage Current	—	—	±100	nA	V _{GE} = ±20V	

Switching Characteristics @ T_J = 25°C (unless otherwise specified)

	Parameter	Min.	Typ.	Max.	Units	Conditions	Ref.Fig.
Q _g	Total Gate Charge (turn-on)	—	340	510	nC	I _C = 40A	23
Q _{ge}	Gate - Emitter Charge (turn-on)	—	40	60		V _{CC} = 600V	CT1
Q _{gc}	Gate - Collector Charge (turn-on)	—	165	248		V _{GE} = 15V	
E _{on}	Turn-On Switching Loss	—	1400	1750	μJ	I _C = 40A, V _{CC} = 600V	CT4
E _{off}	Turn-Off Switching Loss	—	1650	2050		V _{GE} = 15V, R _G = 4.7Ω, L = 200μH	WF1
E _{tot}	Total Switching Loss	—	3050	3800	μJ	L _s = 150nH T _J = 25°C	WF2
E _{on}	Turn-On Switching Loss	—	1950	2300		T _J = 125°C	13,15
E _{off}	Turn-Off Switching Loss	—	2200	2950		Energy losses include "tail" and diode reverse recovery.	
E _{tot}	Total Switching Loss	—	4150	5250			
t _{d(on)}	Turn-On Delay Time	—	76	99	ns	I _C = 40A, V _{CC} = 600V	14, 16
t _r	Rise Time	—	39	55		V _{GE} = 15V, R _G = 4.7Ω, L = 200μH	CT4
t _{d(off)}	Turn-Off Delay Time	—	332	365		L _s = 150nH, T _J = 125°C	WF1
t _f	Fall Time	—	25	33			WF2
C _{ies}	Input Capacitance	—	4300	—	pF	V _{GE} = 0V	22
C _{oes}	Output Capacitance	—	330	—		V _{CC} = 30V	
C _{res}	Reverse Transfer Capacitance	—	160	—		f = 1.0MHz	
RBSOA	Reverse Bias Safe Operating Area	FULL SQUARE				T _J = 150°C, I _C = 160A, V _p = 1200V V _{CC} = 1000V, V _{GE} = +15V to 0V R _G = 4.7Ω	4 CT2
SCSOA	Short Circuit Safe Operating Area	10	—	—	μs	T _J = 150°C, V _p = 1200V V _{CC} = 900V, V _{GE} = +15V to 0V, R _G = 4.7Ω	CT3 WF4
E _{rec}	Reverse Recovery energy of the diode	—	3346	—	μJ	T _J = 125°C	17,18,19
t _{rr}	Diode Reverse Recovery time	—	180	—	ns	V _{CC} = 600V, I _F = 60A, L = 200μH	20, 21
I _{rr}	Diode Peak Reverse Recovery Current	—	50	—	A	V _{GE} = 15V, R _G = 4.7Ω, L _s = 150nH	CT4, WF3

IRGPS40B120UDP

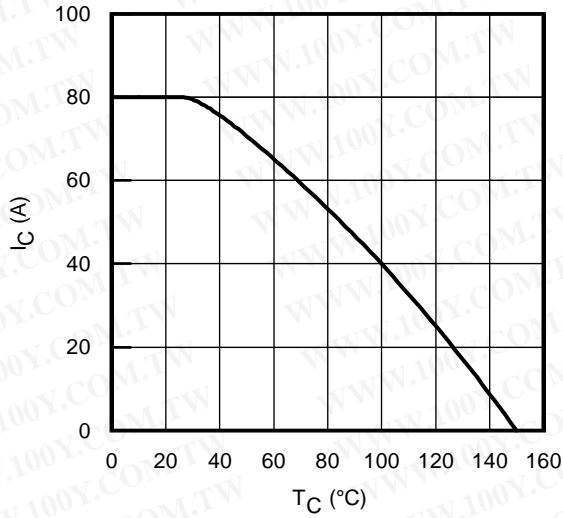

Fig. 1 - Maximum DC Collector Current vs. Case Temperature

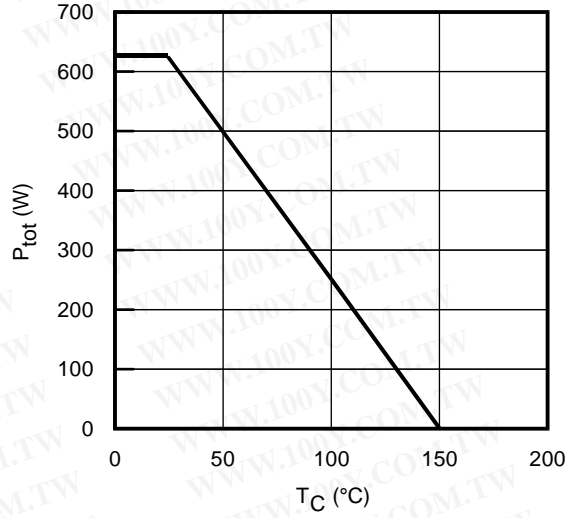

Fig. 2 - Power Dissipation vs. Case Temperature

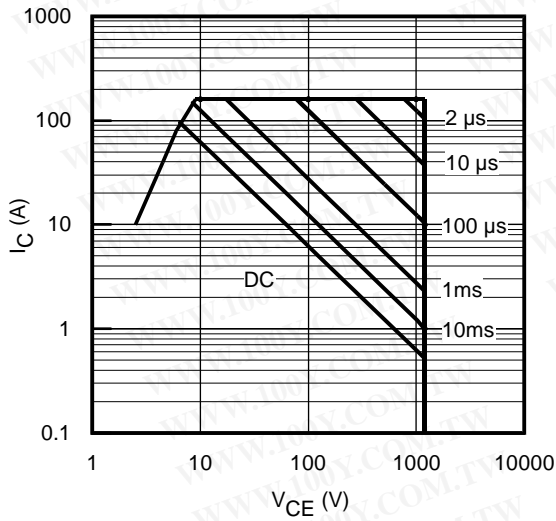

Fig. 3 - Forward SOA
 $T_C = 25^\circ\text{C}$; $T_{JS} \leq 150^\circ\text{C}$

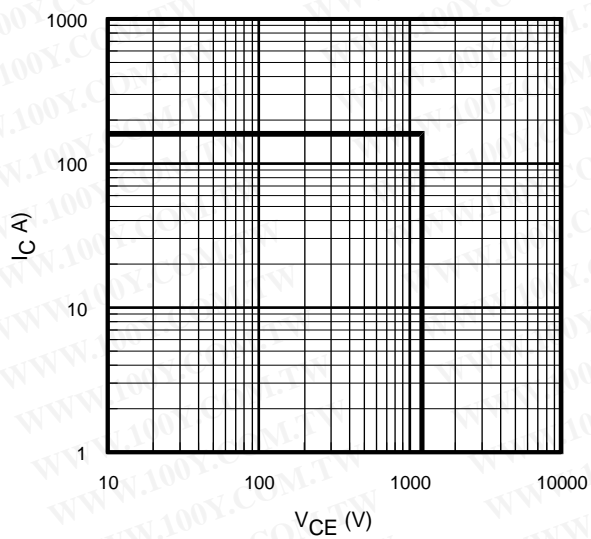

Fig. 4 - Reverse Bias SOA
 $T_J = 150^\circ\text{C}$; $V_{GE} = 15\text{V}$

IRGPS40B120UDP

International
IR Rectifier

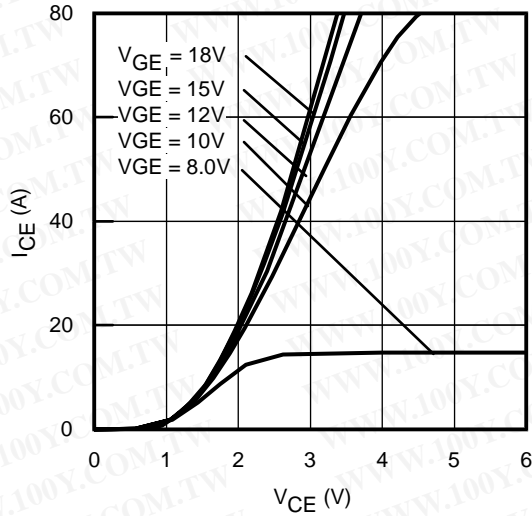

Fig. 5 - Typ. IGBT Output Characteristics
 $T_J = -40^\circ\text{C}$; $t_p = 80\mu\text{s}$

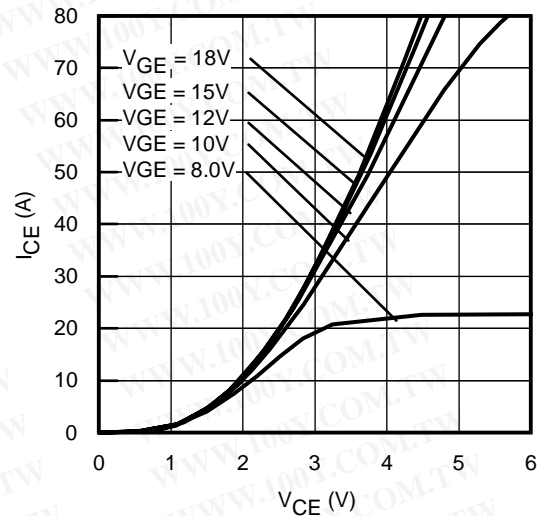

Fig. 6 - Typ. IGBT Output Characteristics
 $T_J = 25^\circ\text{C}$; $t_p = 80\mu\text{s}$

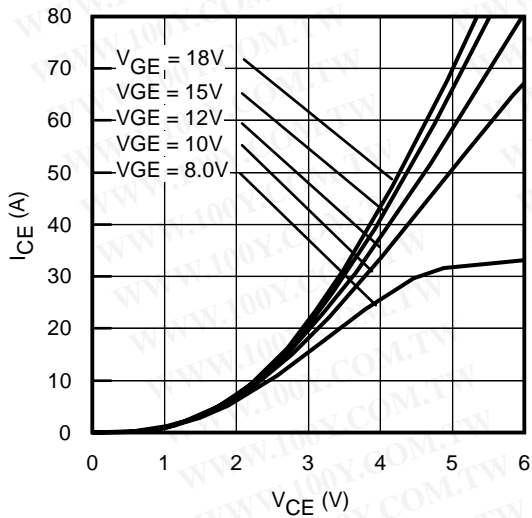

Fig. 7 - Typ. IGBT Output Characteristics
 $T_J = 125^\circ\text{C}$; $t_p = 80\mu\text{s}$

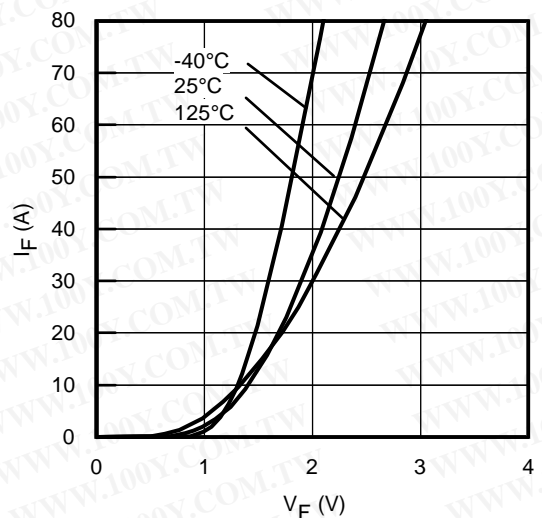

Fig. 8 - Typ. Diode Forward Characteristics
 $t_p = 80\mu\text{s}$

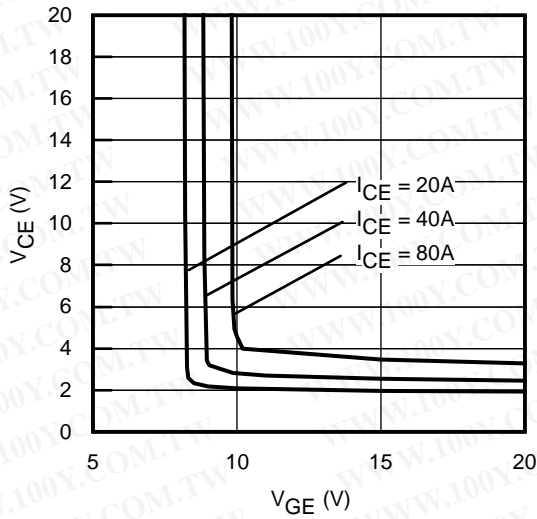

Fig. 9 - Typical V_{CE} vs. V_{GE}
 $T_J = -40^\circ\text{C}$

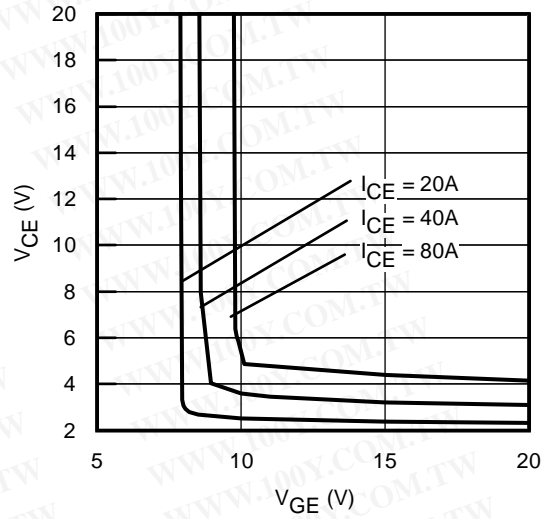

Fig. 10 - Typical V_{CE} vs. V_{GE}
 $T_J = 25^\circ\text{C}$

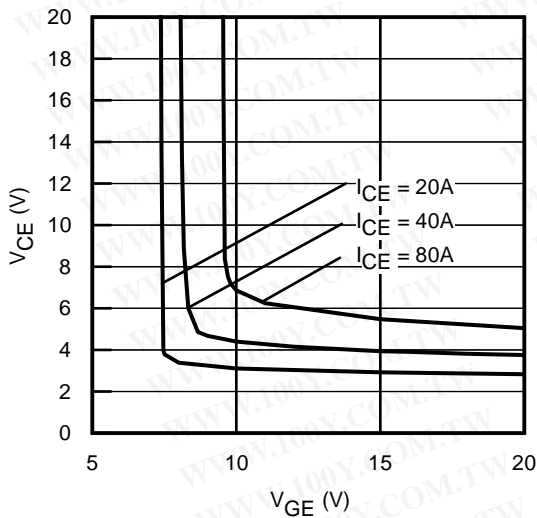

Fig. 11 - Typical V_{CE} vs. V_{GE}
 $T_J = 125^\circ\text{C}$

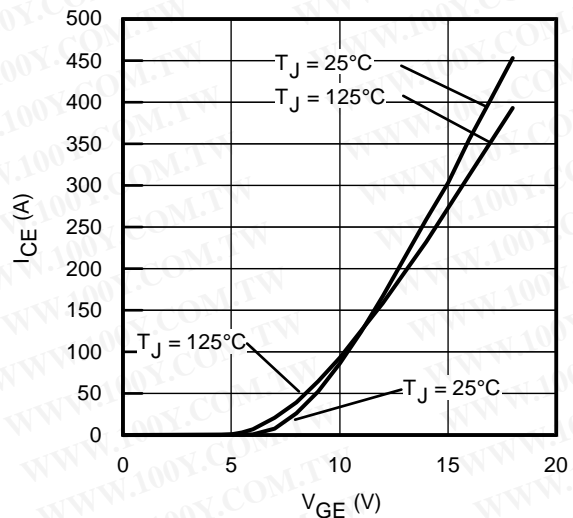

Fig. 12 - Typ. Transfer Characteristics
 $V_{CE} = 50\text{V}$; $t_p = 10\mu\text{s}$

IRGPS40B120UDP

International
IRF Rectifier

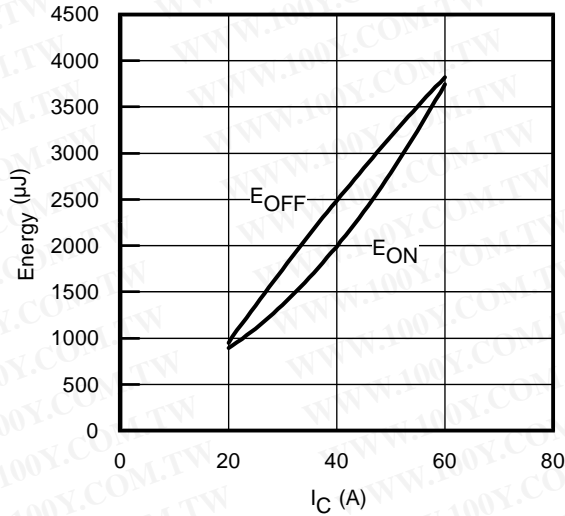

Fig. 13 - Typ. Energy Loss vs. I_C
 $T_J = 125^\circ\text{C}$; $L=200\mu\text{H}$; $V_{CE}=600\text{V}$
 $R_G = 4.7\Omega$; $V_{GE} = 15\text{V}$

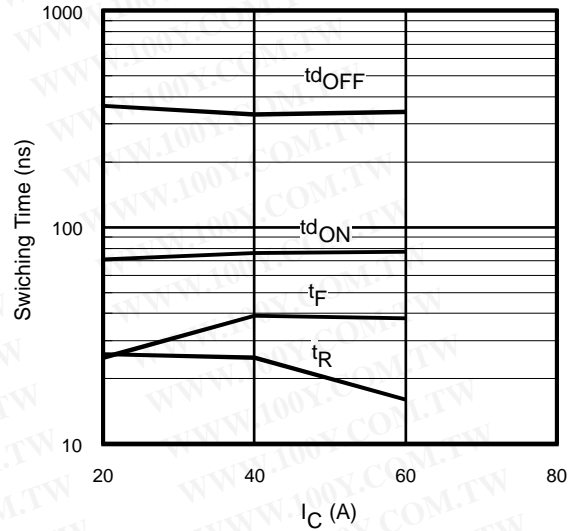

Fig. 14 - Typ. Switching Time vs. I_C
 $T_J = 125^\circ\text{C}$; $L=200\mu\text{H}$; $V_{CE}=600\text{V}$
 $R_G = 4.7\Omega$; $V_{GE} = 15\text{V}$

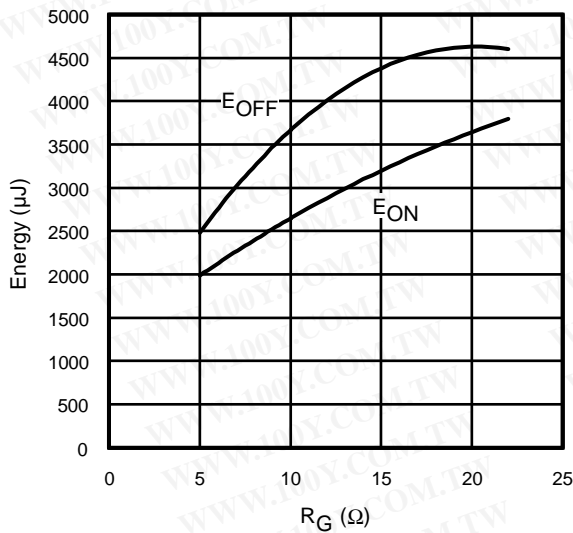

Fig. 15 - Typ. Energy Loss vs. R_G
 $T_J = 125^\circ\text{C}$; $L=200\mu\text{H}$; $V_{CE}=600\text{V}$
 $I_{CE} = 40\text{A}$; $V_{GE} = 15\text{V}$

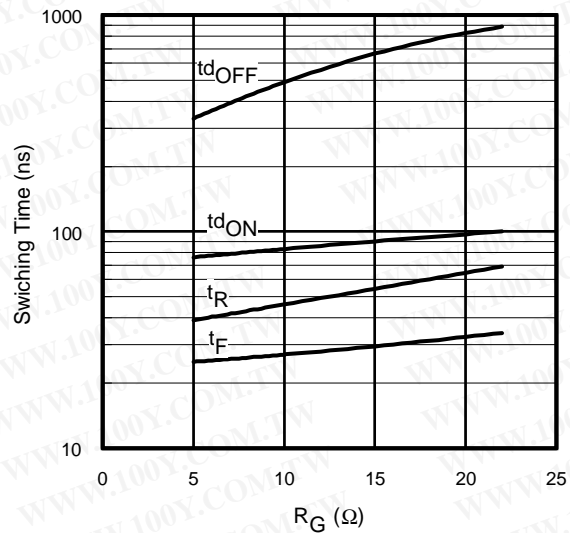

Fig. 16 - Typ. Switching Time vs. R_G
 $T_J = 125^\circ\text{C}$; $L=200\mu\text{H}$; $V_{CE}=600\text{V}$
 $I_{CE} = 40\text{A}$; $V_{GE} = 15\text{V}$

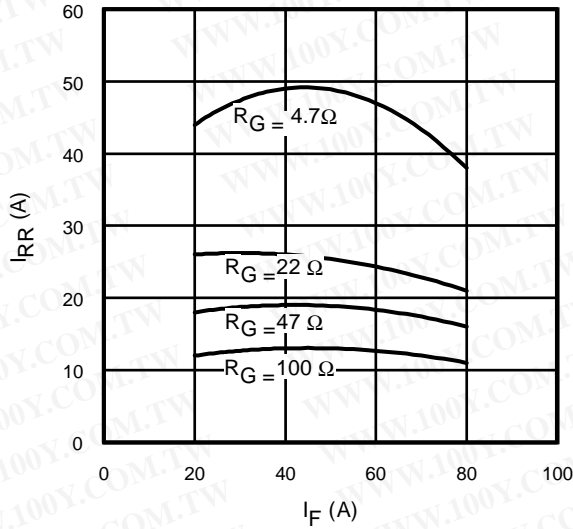

Fig. 17 - Typical Diode I_{RR} vs. I_F
 $T_J = 125^\circ\text{C}$

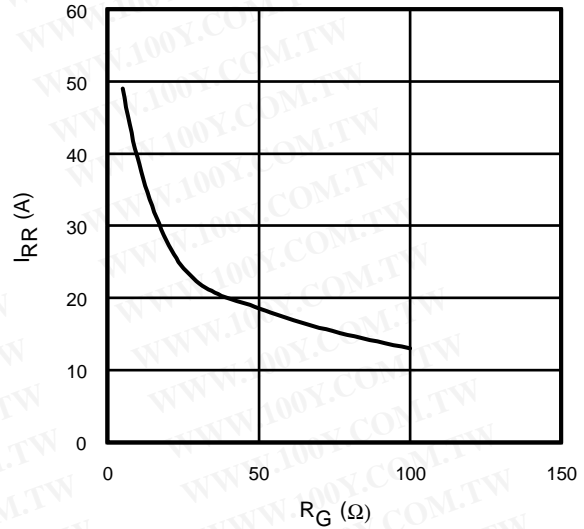

Fig. 18 - Typical Diode I_{RR} vs. R_G
 $T_J = 125^\circ\text{C}; I_F = 40\text{A}$

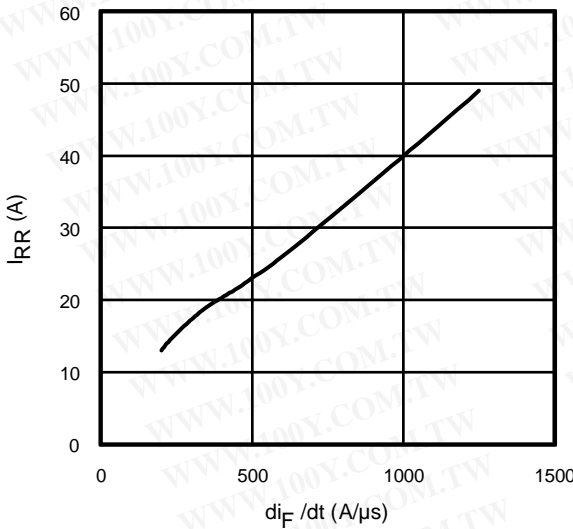

Fig. 19- Typical Diode I_{RR} vs. di_F/dt
 $V_{CC} = 600\text{V}; V_{GE} = 15\text{V};$
 $I_{CE} = 40\text{A}; T_J = 125^\circ\text{C}$

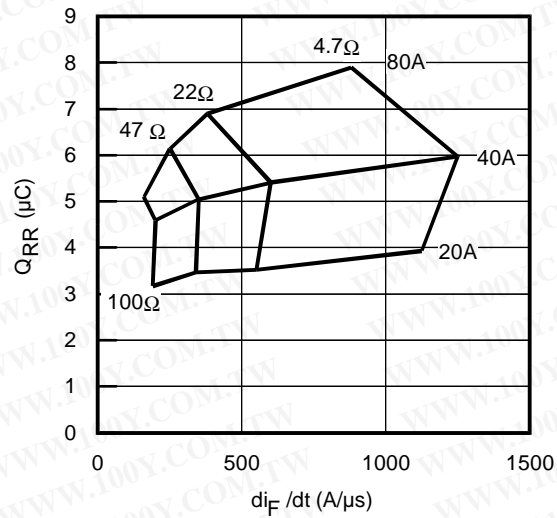

Fig. 20 - Typical Diode Q_{RR}
 $V_{CC} = 600\text{V}; V_{GE} = 15\text{V}; T_J = 125^\circ\text{C}$

IRGPS40B120UDP

International
IR Rectifier

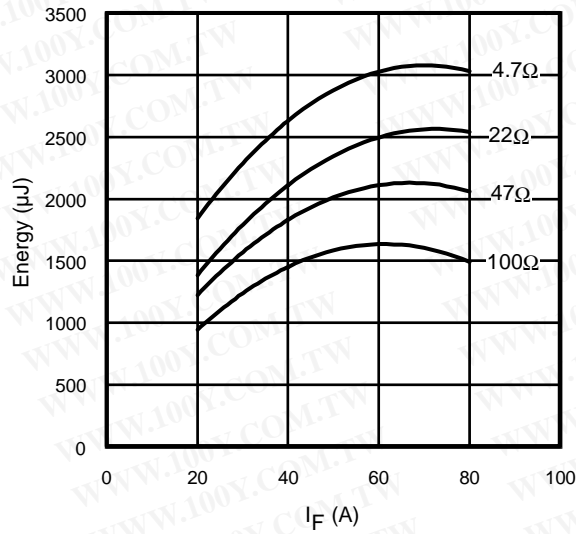

Fig. 21 - Typical Diode E_{RR} vs. I_F
 $T_J = 125^\circ\text{C}$

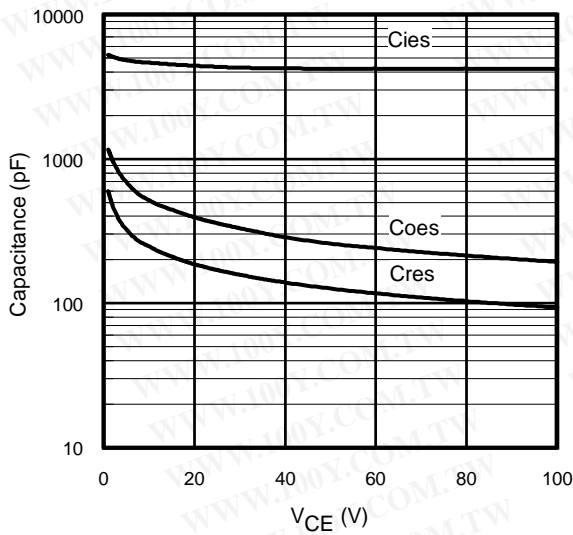

Fig. 22- Typ. Capacitance vs. V_{CE}
 $V_{GE} = 0\text{V}$; $f = 1\text{MHz}$

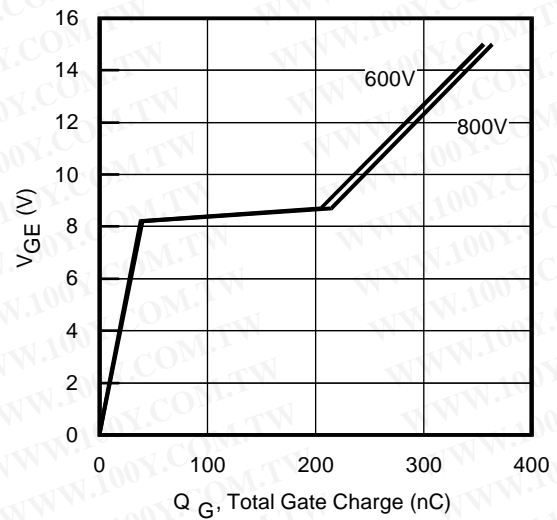

Fig. 23 - Typical Gate Charge vs. V_{GE}
 $I_{CE} = 40\text{A}$; $L = 600\mu\text{H}$

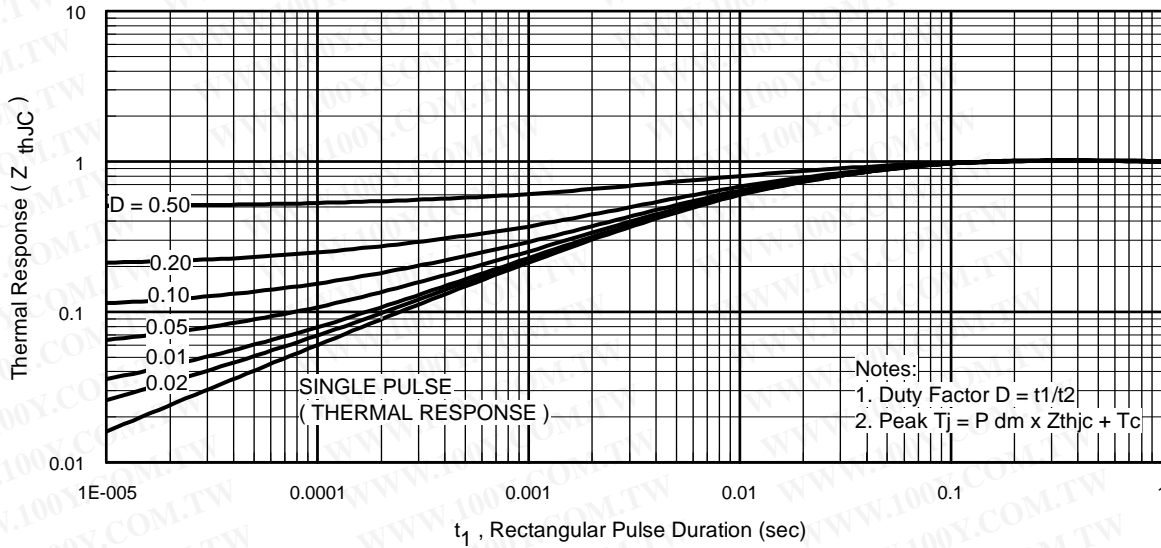

Fig 24. Normalized Transient Thermal Impedance, Junction-to-Case (IGBT)

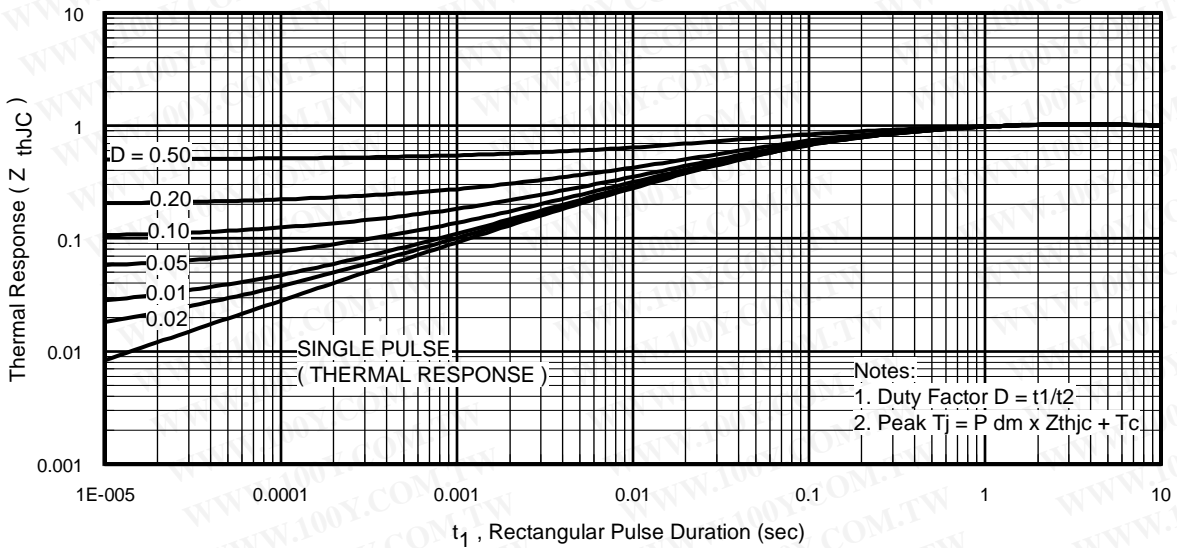

Fig 25. Normalized Transient Thermal Impedance, Junction-to-Case (DIODE)

IRGFS40B120UDP

International
IR Rectifier

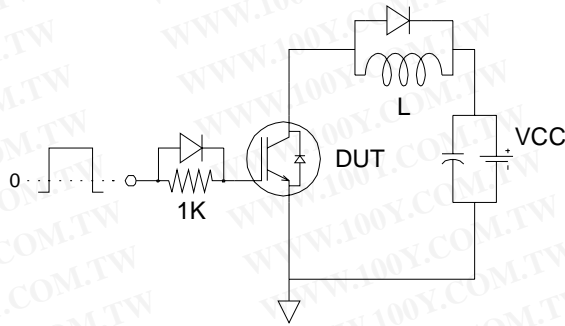

Fig.C.T.1 - Gate Charge Circuit (turn-on)

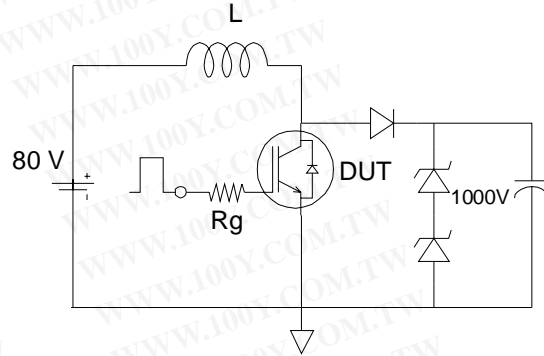

Fig.C.T.2 - RBSOA Circuit

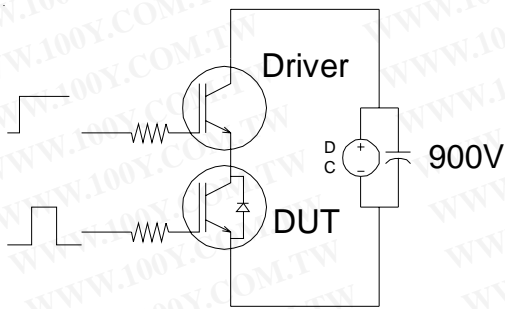

Fig.C.T.3 - RBSOA Circuit

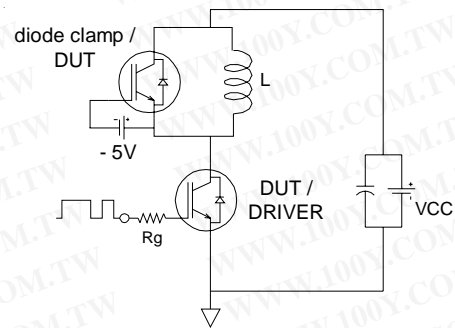

Fig.C.T.4 - RBSOA Circuit

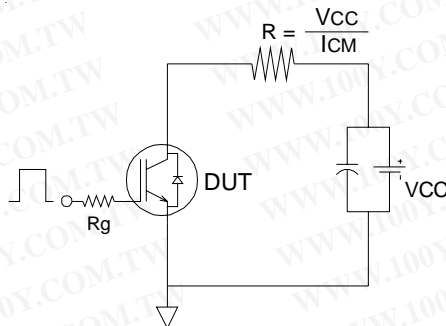

Fig.C.T.5 - RBSOA Circuit

IRGPS40B120UDP

Fig. WF.1 - Typ. Turn-off Loss Waveform
 @ $T_j=125^\circ\text{C}$ using Fig. CT.4

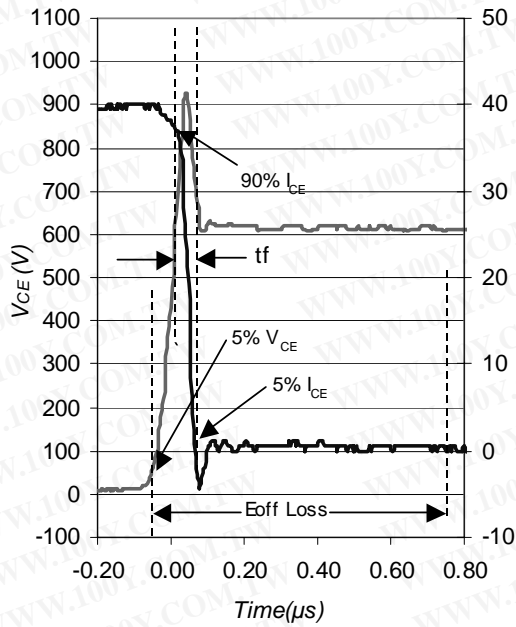

Fig. WF.2 - Typ. Turn-on Loss Waveform
 @ $T_j=125^\circ\text{C}$ using Fig. CT.4

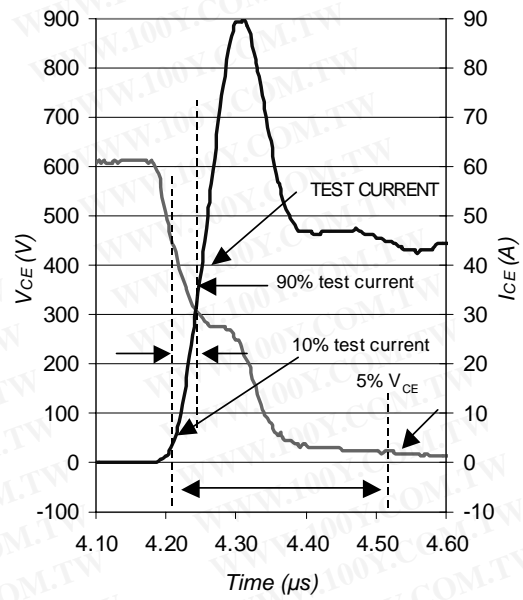

Fig. WF.3 - Typ. Diode Recovery Waveform
 @ $T_j=125^\circ\text{C}$ using Fig. CT.4

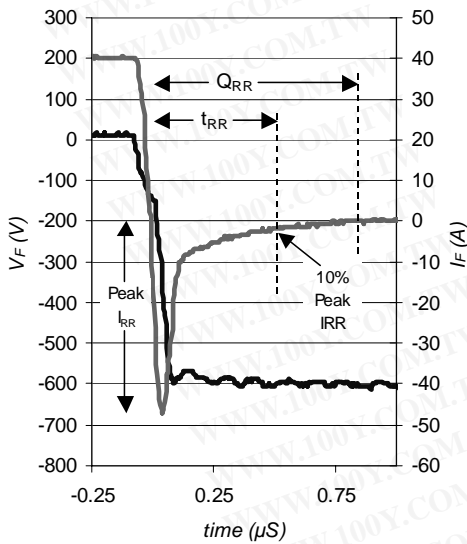
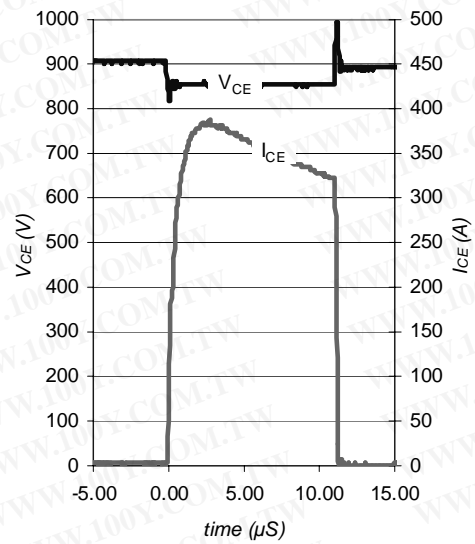

Fig. WF.4 - Typ. S.C. Waveform
 @ $T_C=150^\circ\text{C}$ using Fig. CT.3



勝特力材料 886-3-5753170
 勝特力电子(上海) 86-21-34970699
 勝特力电子(深圳) 86-755-83298787
 Http://www.100y.com.tw

IRGPS40B120UDP

Case Outline and Dimensions — Super-247

International
IR Rectifier

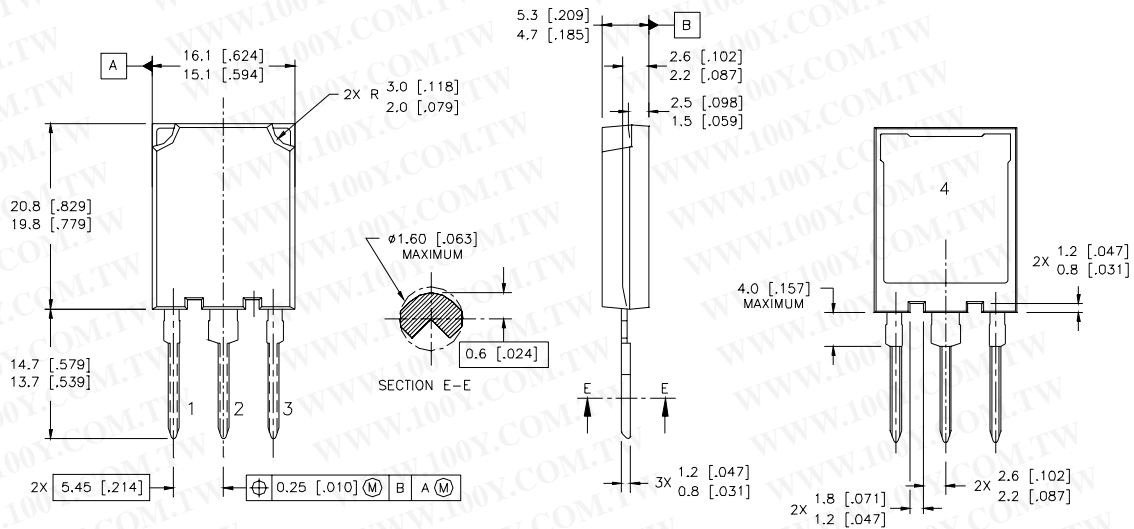

- NOTES:
1. DIMENSIONS & TOLERANCING PER ASME Y14.5M-1994
 2. CONTROLLING DIMENSION: MILLIMETER
 3. DIMENSIONS ARE SHOWN IN MILLIMETRES [INCHES]

LEAD ASSIGNMENTS

MOSFET	IGBT
1 - GATE	1 - GATE
2 - DRAIN	2 - COLLECTOR
3 - SOURCE	3 - EMITTER
4 - DRAIN	4 - COLLECTOR

Super-247 (TO-274AA) Part Marking Information

EXAMPLE: THIS IS AN IRFPS37N50A WITH
ASSEMBLY LOT CODE 1789
ASSEMBLED ON WW 19, 1997
IN THE ASSEMBLY LINE "C"

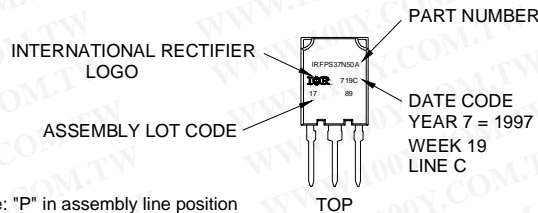

Note: "P" in assembly line position indicates "Lead-Free"

① $V_{CC} = 80\% (V_{CES}), V_{GE} = 20V, L = 100 \mu H, R_G = 4.7\Omega$.

Data and specifications subject to change without notice.
This product has been designed and qualified for the industrial market.
Qualification Standards can be found on IR's Web site.

International
IR Rectifier

IR WORLD HEADQUARTERS: 233 Kansas St., El Segundo, California 90245, USA Tel: (310) 252-7105
TAC Fax: (310) 252-7903

Visit us at www.irf.com for sales contact information.11/04