

# Standard Rectifier

勝特力材料 886-3-5753170  
 勝特力电子(上海) 86-21-34970699  
 勝特力电子(深圳) 86-755-83298787  
[Http://www.100y.com.tw](http://www.100y.com.tw)

3~ Rectifier	
$V_{RRM}$	= 1600 V
$I_{DAV}$	= 50 A
$I_{FSM}$	= 270 A

## 3~ Rectifier Bridge

Part number

**FUO50-16N**

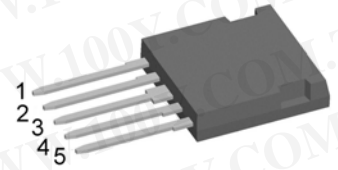

Backside: isolated

E72873

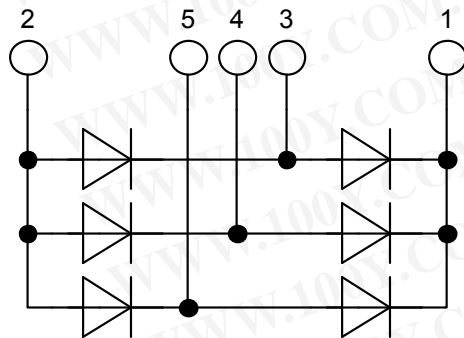

### Features / Advantages:

- Package with DCB ceramic
- Reduced weight
- Improved temperature and power cycling
- Planar passivated chips
- Very low forward voltage drop
- Very low leakage current

### Applications:

- Diode for main rectification
- For single and three phase bridge configurations

### Package: i4-Pac

- Isolation Voltage: 3000V~
- Industry convenient outline
- RoHS compliant
- Epoxy meets UL 94V-0
- Soldering pins for PCB mounting
- Backside: DCB ceramic
- Reduced weight
- Advanced power cycling

Rectifier				Ratings			
Symbol	Definition	Conditions	min.	typ.	max.	Unit	
$V_{RSM}$	max. non-repetitive reverse blocking voltage				1700	V	
$V_{RRM}$	max. repetitive reverse blocking voltage				1600	V	
$I_R$	reverse current, drain current	$V_R = 1600$ V	$T_{VJ} = 25^\circ\text{C}$		20	$\mu\text{A}$	
		$V_R = 1600$ V	$T_{VJ} = 150^\circ\text{C}$		1	mA	
$V_F$	forward voltage drop	$I_F = 15$ A	$T_{VJ} = 25^\circ\text{C}$		1.15	V	
					1.50	V	
		$I_F = 45$ A	$T_{VJ} = 150^\circ\text{C}$		1.04	V	
					1.55	V	
$I_{DAV}$	bridge output current	$T_c = 120^\circ\text{C}$ rectangular $d = \frac{1}{3}$	$T_{VJ} = 175^\circ\text{C}$		50	A	
$V_{FO}$	threshold voltage	} for power loss calculation only	$T_{VJ} = 175^\circ\text{C}$		0.78	V	
$r_F$	slope resistance				17	m $\Omega$	
$R_{thJC}$	thermal resistance junction to case				2.1	K/W	
$R_{thCH}$	thermal resistance case to heatsink			0.20		K/W	
$P_{tot}$	total power dissipation		$T_c = 25^\circ\text{C}$		70	W	
$I_{FSM}$	max. forward surge current	$t = 10$ ms; (50 Hz), sine	$T_{VJ} = 45^\circ\text{C}$		270	A	
					290	A	
		$t = 8,3$ ms; (60 Hz), sine	$V_R = 0$ V		230	A	
					250	A	
$I^2t$	value for fusing	$t = 10$ ms; (50 Hz), sine	$T_{VJ} = 45^\circ\text{C}$		365	A <sup>2</sup> s	
					350	A <sup>2</sup> s	
		$t = 8,3$ ms; (60 Hz), sine	$V_R = 0$ V		265	A <sup>2</sup> s	
					260	A <sup>2</sup> s	
$C_J$	junction capacitance	$V_R = 400$ V; $f = 1$ MHz	$T_{VJ} = 25^\circ\text{C}$		8	pF	

勝特力材料 886-3-5753170  
 勝特力电子(上海) 86-21-34970699  
 勝特力电子(深圳) 86-755-83298787  
[Http://www.100y.com.tw](http://www.100y.com.tw)

Package i4-Pac			Ratings			
Symbol	Definition	Conditions	min.	typ.	max.	Unit
$I_{RMS}$	RMS current	per terminal			50	A
$T_{stg}$	storage temperature		-55		150	°C
$T_{vj}$	virtual junction temperature		-55		175	°C
<b>Weight</b>				9		g
$F_C$	mounting force with clip		20		120	N
$d_{Spp/App}$	creepage distance on surface   striking distance through air	terminal to terminal	1.7			mm
$d_{Spb/Abp}$		terminal to backside	5.1			mm
$V_{ISOL}$	isolation voltage	t = 1 second	3000			V
		t = 1 minute	2500			V

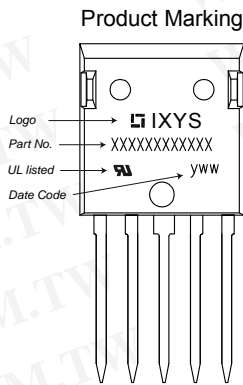

勝特力材料 886-3-5753170  
 勝特力电子(上海) 86-21-34970699  
 勝特力电子(深圳) 86-755-83298787  
[Http://www.100y.com.tw](http://www.100y.com.tw)

Ordering	Part Number	Marking on Product	Delivery Mode	Quantity	Code No.
Standard	FUO50-16N	FUO50-16N	Tube	25	498637

### Equivalent Circuits for Simulation

\* on die level

$T_{vj} = 175^\circ\text{C}$

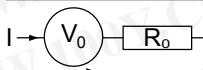

Rectifier

$V_{0\max}$	threshold voltage	0.78	V
$R_{0\max}$	slope resistance *	14	mΩ

## Outlines i4-Pac

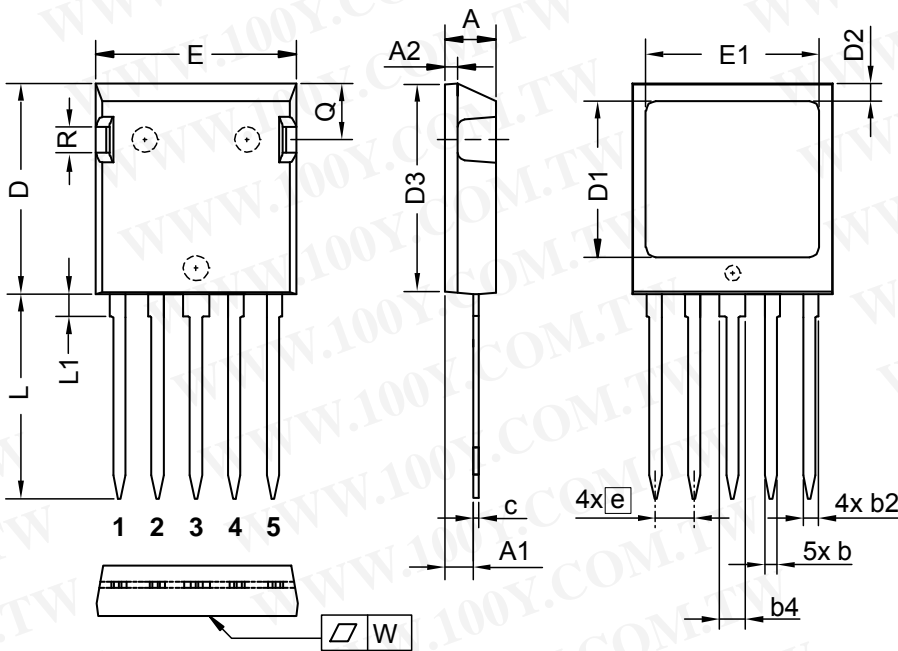

Dim.	Millimeter		Inches	
	min	max	min	max
A	4.83	5.21	0.190	0.205
A1	2.59	3.00	0.102	0.118
A2	1.17	2.16	0.046	0.085
b	1.14	1.40	0.045	0.055
b2	1.47	1.73	0.058	0.068
b4	2.54	2.79	0.100	0.110
c	0.51	0.74	0.020	0.029
D	20.80	21.34	0.819	0.840
D1	14.99	15.75	0.590	0.620
D2	1.65	2.03	0.065	0.080
D3	20.30	20.70	0.799	0.815
E	19.56	20.29	0.770	0.799
E1	16.76	17.53	0.660	0.690
e	3.81	BSC	0.150	BSC
L	19.81	21.34	0.780	0.840
L1	2.11	2.59	0.083	0.102
Q	5.33	6.20	0.210	0.244
R	2.54	4.57	0.100	0.180
W	-	0.10	-	0.004

Die konvexe Form des Substrates ist typ. < 0.05 mm über der Kunststoffoberfläche der Bauteilunterseite  
 The convex bow of substrate is typ. < 0.05 mm over plastic surface level of device bottom side

**勝特力材料 886-3-5753170**  
**勝特力电子(上海) 86-21-34970699**  
**勝特力电子(深圳) 86-755-83298787**  
[Http://www.100y.com.tw](http://www.100y.com.tw)

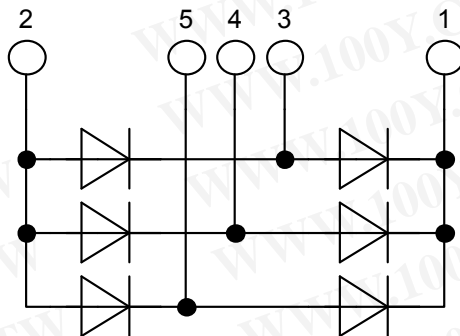

### Rectifier

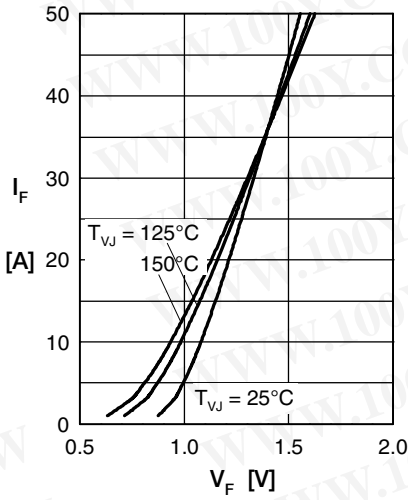

Fig. 1 Forward current versus voltage drop per diode

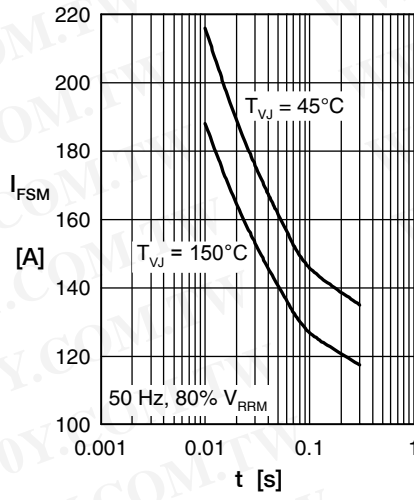

Fig. 2 Surge overload current

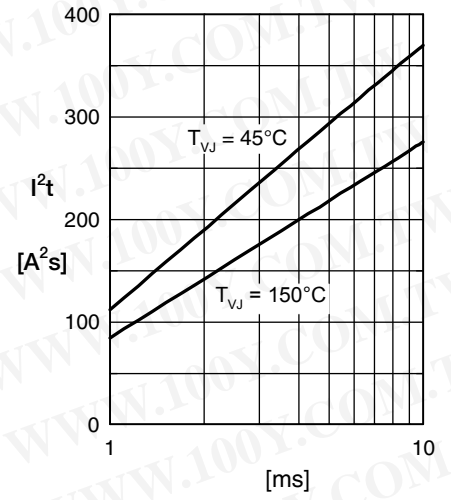

Fig. 3  $I^2t$  versus time per diode

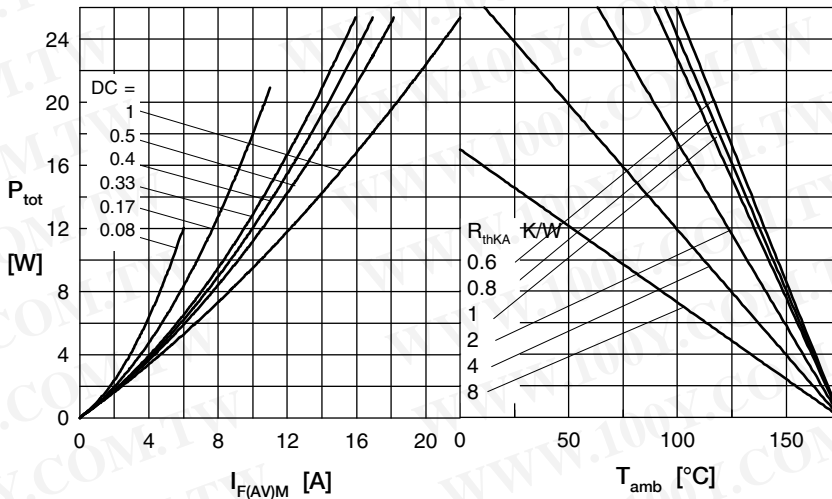

Fig. 4 Power dissipation vs. direct output current & ambient temperature

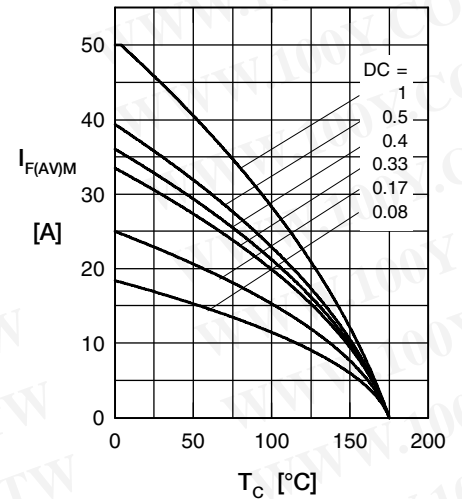

Fig. 5 Max. forward current vs. case temperature

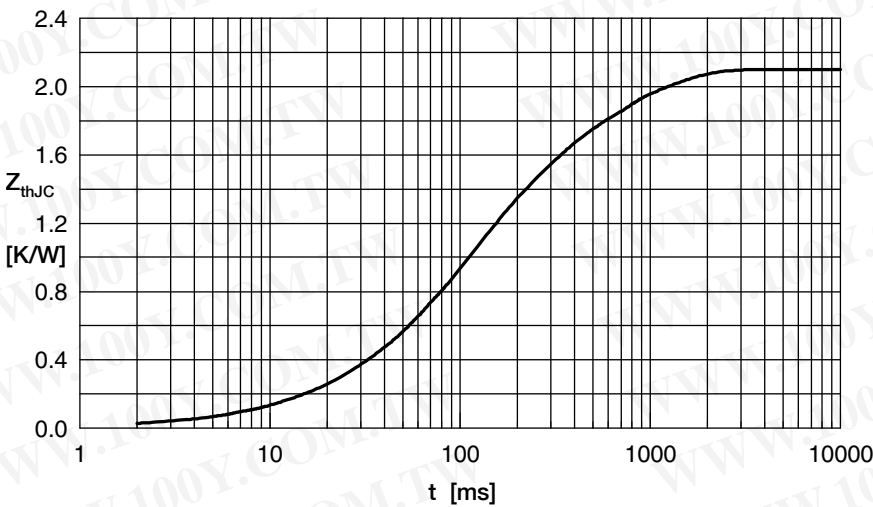

Fig. 6 Transient thermal impedance junction to case

Constants for  $Z_{thJC}$  calculation:

i	$R_{thi}$ (K/W)	$t_i$ (s)
1	1.159	0.1015
2	0.1286	0.1026
3	0.2651	0.4919
4	0.5473	0.62