

AC Controller Modules

$I_{RMS} = 54 \text{ A}$
 $V_{RRM} = 1200-1600 \text{ V}$

V_{RSM} V_{DSM} V	V_{RRM} V_{DRM} V	Type
1200	1200	MMO 62-12io6
1600	1600	MMO 62-16io6

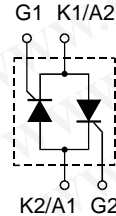

miniBLOC, SOT-227 B

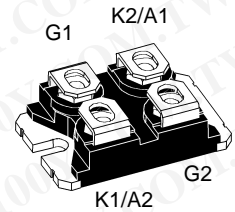

Symbol	Test Conditions	Maximum Ratings	Features
I_{RMS}	$T_C = 110^\circ\text{C}$, 50 - 400 Hz, module	54 A	<ul style="list-style-type: none"> • Thyristor controller for AC (circuit W1C acc. to IEC) for mains frequency • International standard package miniBLOC (ISOTOP compatible) • Isolation voltage 2500 V~ • Planar passivated chips • UL registered, E 72873
I_{TRMS}	$T_{VJ} = T_{VJM}$	39 A	
I_{TAVM}	$T_C = 110^\circ\text{C}$; (180° sine)	25 A	
I_{TSM}	$T_{VJ} = 45^\circ\text{C}$; $V_R = 0$	t = 10 ms (50 Hz), sine t = 8.3 ms (60 Hz), sine	400 A 430 A
	$T_{VJ} = T_{VJM}$ $V_R = 0$	t = 10 ms (50 Hz), sine t = 8.3 ms (60 Hz), sine	350 A 370 A
I^2t	$T_{VJ} = 45^\circ\text{C}$ $V_R = 0$	t = 10 ms (50 Hz), sine t = 8.3 ms (60 Hz), sine	800 A ² s 780 A ² s
	$T_{VJ} = T_{VJM}$ $V_R = 0$	t = 10 ms (50 Hz), sine t = 8.3 ms (60 Hz), sine	610 A ² s 570 A ² s
$(di/dt)_{cr}$	$T_{VJ} = T_{VJM}$ f = 50 Hz, t _p = 200 μs $V_D = 2/3 V_{DRM}$ $I_G = 0.3 \text{ A}$ di _G /dt = 0.3 A/μs	repetitive, I _T = 150 A	100 A/μs
		non repetitive, I _T = I _{TAVM}	500 A/μs
$(dv/dt)_{cr}$	$T_{VJ} = T_{VJM}$; R _{GK} = ∞; method 1 (linear voltage rise)	$V_{DR} = 2/3 V_{DRM}$	1000 V/μs
P_{GM}	$T_{VJ} = T_{VJM}$ I _T = I _{TAVM}	t _p = 30 μs	10 W
		t _p = 300 μs	5 W
P_{GAVM}			0.5 W
V_{RGM}			10 V
T_{VJ}			-40...+150 °C
T_{VJM}			150 °C
T_{stg}			-40...+150 °C
V_{ISOL}	50/60 Hz, RMS I _{ISOL} ≤ 1 mA		2500 V~
M_d	Mounting torque (M4)	1.1 - 1.5 / 9 - 13	Nm/lb.in.
	Terminal connection torque (M4)	1.1 - 1.5 / 9 - 13	Nm/lb.in.
Weight	typ.	30	g

Features

- Thyristor controller for AC (circuit W1C acc. to IEC) for mains frequency
- International standard package miniBLOC (ISOTOP compatible)
- Isolation voltage 2500 V~
- Planar passivated chips
- UL registered, E 72873

Applications

- Switching and control of single and three phase AC
- Softstart AC motor controller
- Solid state switches
- Light and temperature control

Advantages

- Easy to mount with two screws
- Space and weight savings
- Improved temperature and power cycling
- High power density

Data according to IEC 60747 and to a single thyristor/diode unless otherwise stated.
 IXYS reserves the right to change limits, test conditions and dimensions.

Symbol	Test Conditions	Characteristic Values	
$I_{R,D}$	$T_{VJ} = T_{VJM}; V_R = V_{RRM}; V_D = V_{DRM}$	\leq	12 mA
V_T	$I_T = 45 \text{ A}; T_{VJ} = 25^\circ\text{C}$	\leq	1.57 V
V_{T0}	For power-loss calculations only		0.85 V
r_T			12 m Ω
V_{GT}	$V_D = 6 \text{ V}; T_{VJ} = 25^\circ\text{C}$	\leq	1.5 V
	$T_{VJ} = -40^\circ\text{C}$	\leq	1.6 V
I_{GT}	$V_D = 6 \text{ V}; T_{VJ} = 25^\circ\text{C}$	\leq	100 mA
	$T_{VJ} = -40^\circ\text{C}$	\leq	150 mA
V_{GD}	$T_{VJ} = T_{VJM}; V_D = 2/3 V_{DRM}$	\leq	0.2 V
I_{GD}		\leq	5 mA
I_L	$T_{VJ} = 25^\circ\text{C}; t_p = 10 \mu\text{s}$ $I_G = 0.3 \text{ A}; di_G/dt = 0.3 \text{ A}/\mu\text{s}$	\leq	250 mA
I_H	$T_{VJ} = 25^\circ\text{C}; V_D = 6 \text{ V}; R_{GK} = \infty$	\leq	100 mA
t_{gd}	$T_{VJ} = 25^\circ\text{C}; V_D = 1/2 V_{DRM}$ $I_G = 0.3 \text{ A}; di_G/dt = 0.3 \text{ A}/\mu\text{s}$	\leq	2 μs
t_q	$T_{VJ} = T_{VJM}; I_T = 20 \text{ A}, t_p = 200 \mu\text{s}; di/dt = -10 \text{ A}/\mu\text{s}$ $V_R = 100 \text{ V}; dv/dt = 15 \text{ V}/\mu\text{s}; V_D = 2/3 V_{DRM}$	typ.	150 μs
R_{thJC}	per thyristor; DC current		0.91 K/W
	per module		0.455 K/W
R_{thCH}	per thyristor; DC current	typ.	0.1 K/W
	per module	typ.	0.05 K/W
d_s	Creeping distance on surface		8 mm
d_A	Creepage distance in air		4 mm
a	Max. allowable acceleration		50 m/s ²

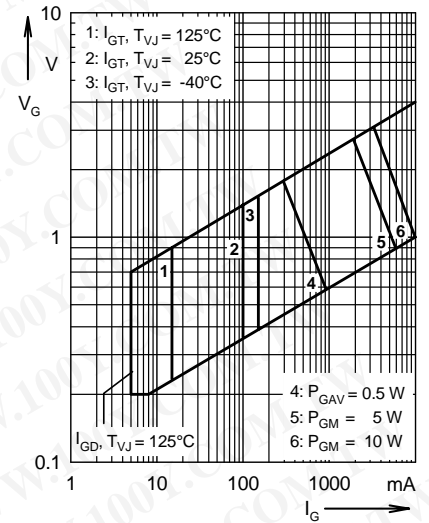

Fig. 1 Gate trigger characteristics

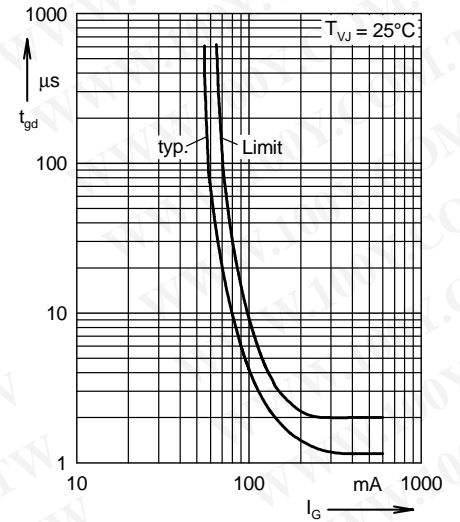

Fig. 2 Gate trigger delay time

miniBLOC, SOT-227 B

Dim.	Millimeter		Inches	
	Min.	Max.	Min.	Max.
A	31.50	31.88	1.240	1.255
B	7.80	8.20	0.307	0.323
C	4.09	4.29	0.161	0.169
D	4.09	4.29	0.161	0.169
E	4.09	4.29	0.161	0.169
F	14.91	15.11	0.587	0.595
G	30.12	30.30	1.186	1.193
H	37.80	38.20	1.489	1.505
J	11.68	12.22	0.460	0.481
K	8.92	9.60	0.351	0.378
L	0.76	0.84	0.030	0.033
M	12.60	12.85	0.496	0.506
N	25.15	25.42	0.990	1.001
O	1.98	2.13	0.078	0.084
P	4.95	5.97	0.195	0.235
Q	26.54	26.90	1.045	1.059
R	3.94	4.42	0.155	0.174
S	4.72	4.85	0.186	0.191
T	24.59	25.07	0.968	0.987
U	-0.05	0.1	-0.002	0.004
V	3.30	4.57	0.130	0.180
W	0.780	0.830	0.031	0.033

M4 screws (4x) supplied

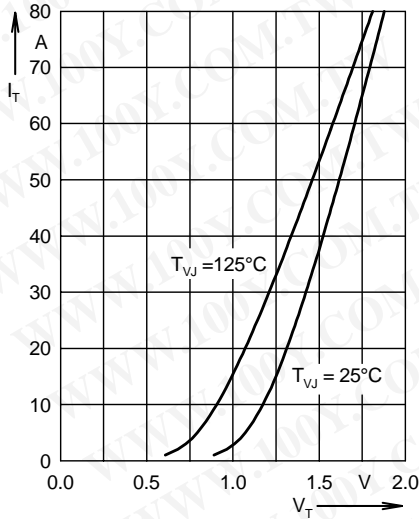

Fig. 3 Forward current versus voltage drop per leg

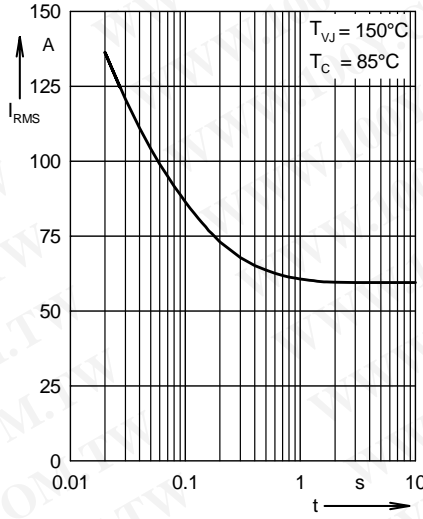

Fig. 4 Rated RMS current versus time (360° conduction)

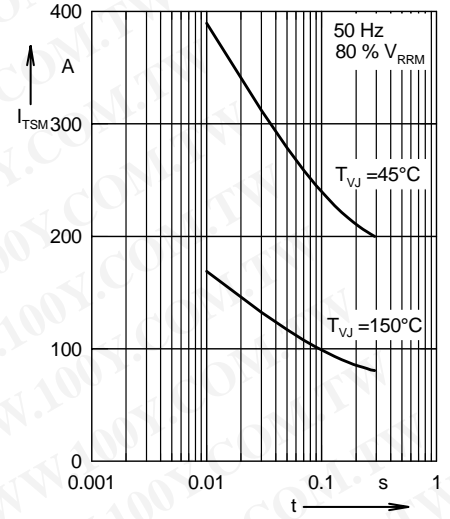

Fig. 5 Surge overload current

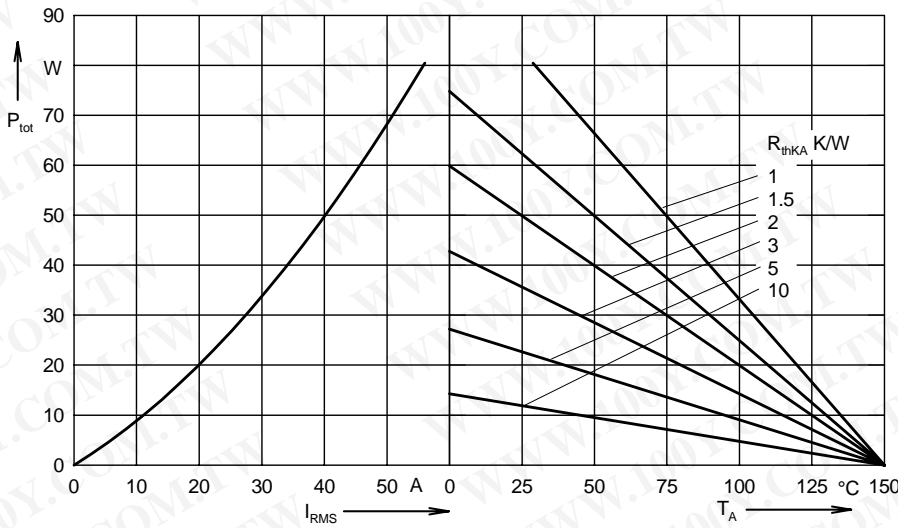

Fig. 6 Load current capability for single AC controller; 1 x MMO62

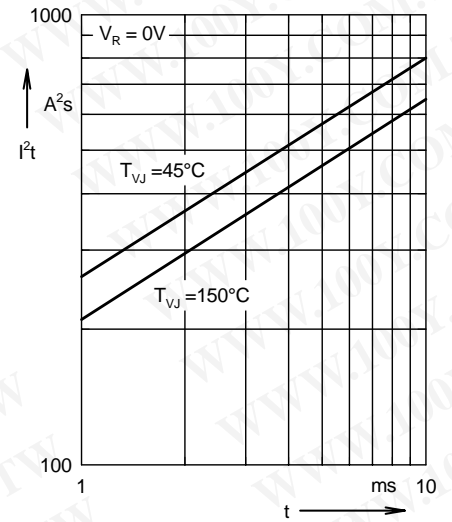

Fig. 7 I^2t versus time (per thyristor)

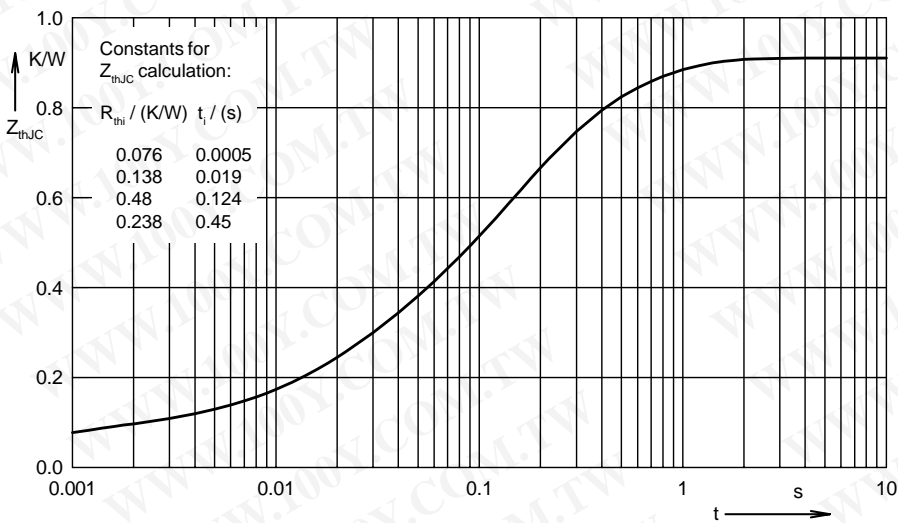

Fig. 8 Transient thermal impedance junction to case (per thyristor)

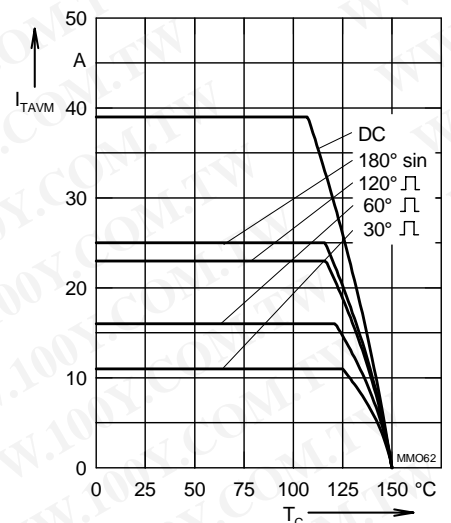

Fig. 9 Maximum forward current at case temperature