

Silicon Switching Diode

- For high-speed switching applications
- High breakdown voltage

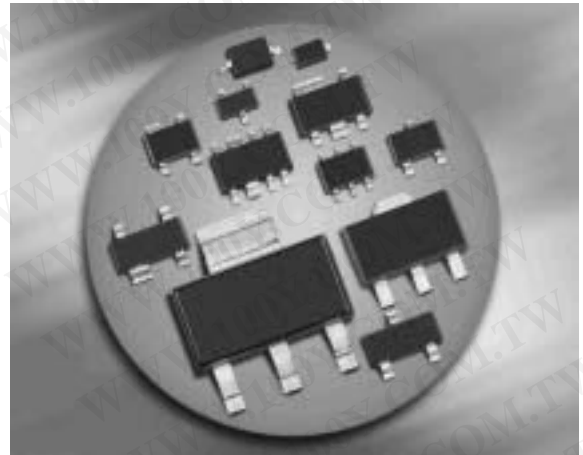

BAS21

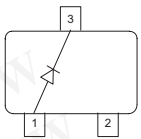

BAS21-03W



BAS21U

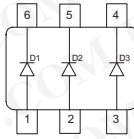

Type	Package	Configuration	Marking
BAS21	SOT23	single	JSs
BAS21-03W	SOD323	single	D
BAS21U	SC74	parallel triple	JSs

Maximum Ratings at $T_A = 25^\circ\text{C}$, unless otherwise specified

Parameter	Symbol	Value	Unit
Diode reverse voltage	V_R	200	V
Peak reverse voltage	V_{RM}	250	
Forward current	I_F	250	mA
Peak forward current	I_{FM}	625	
Surge forward current, $t = 10 \mu\text{s}$	I_{FS}	4	A
Total power dissipation	P_{tot}		mW
BAS21, $T_S \leq 70^\circ\text{C}$		350	
BAS21-03W, $T_S \leq 124^\circ\text{C}$		250	
BAS21U, $T_S \leq 122^\circ\text{C}$		250	
Junction temperature	T_j	150	$^\circ\text{C}$
Storage temperature	T_{stg}	-65 ... 150	

Thermal Resistance

Parameter	Symbol	Value	Unit
Junction - soldering point ¹⁾	R_{thJS}		K/W
BAS21		≤ 230	
BAS21-03W		≤ 105	
BAS21U		≤ 110	

Electrical Characteristics at $T_A = 25^\circ\text{C}$, unless otherwise specified

Parameter	Symbol	Values			Unit
		min.	typ.	max.	

DC Characteristics

Breakdown voltage $I_{(BR)} = 100 \mu\text{A}$	$V_{(BR)}$	250	-	-	V
Reverse current $V_R = 200 \text{ V}$ $V_R = 200 \text{ V}, T_A = 150^\circ\text{C}$	I_R	-	-	0.1 100	μA
Forward voltage $I_F = 100 \text{ mA}$ $I_F = 200 \text{ mA}$	V_F	-	-	1 1.25	V

AC Characteristics

Diode capacitance $V_R = 0 \text{ V}, f = 1 \text{ MHz}$	C_T	-	-	5	pF
Reverse recovery time $I_F = 30 \text{ mA}, I_R = 30 \text{ mA}$, measured at $I_R = 3 \text{ mA}$, $R_L = 100 \Omega$	t_{rr}	-	-	50	ns

Test circuit for reverse recovery time

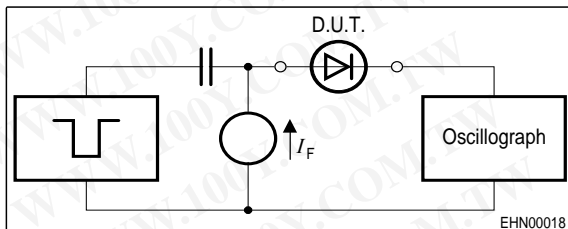

Puls generator: $t_p = 1 \mu\text{s}, D = 0.05$

$t_f = 0.6 \text{ ns}, R_i = 50 \Omega$

Oscilloscope: $R = 50 \Omega, t_r = 0.35 \text{ ns}, C \leq 1 \text{ pF}$

¹⁾For calculation of R_{thJA} please refer to Application Note Thermal Resistance

Reverse current $I_R = f(T_A)$

$V_R = 200V$

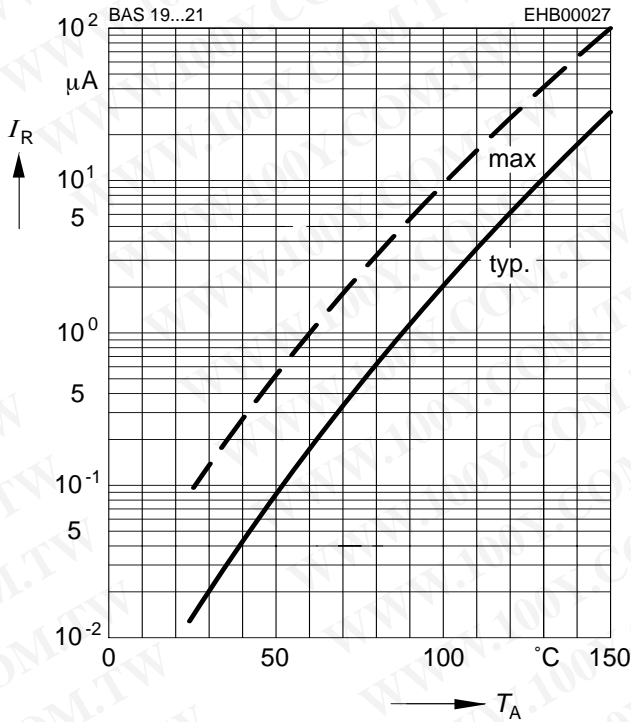

Forward Voltage $V_F = f(T_A)$

$I_F = \text{Parameter}$

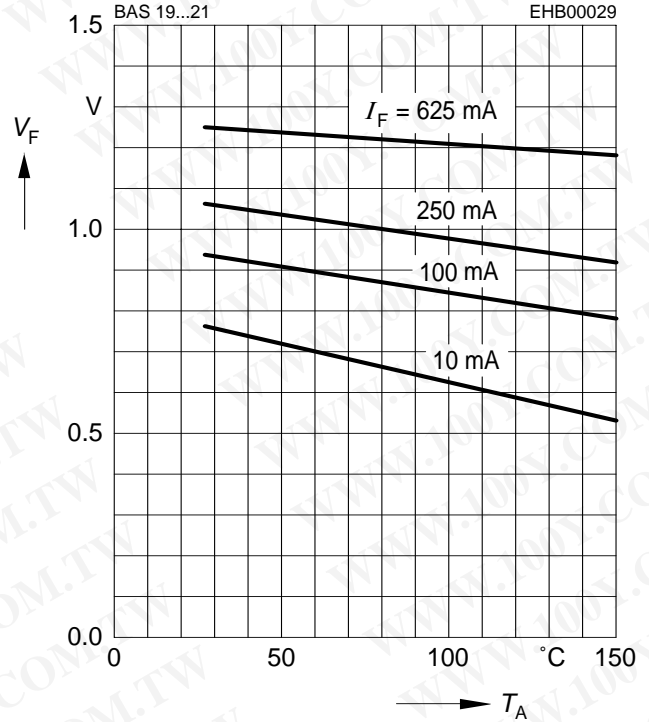

Forward current $I_F = f(V_F)$

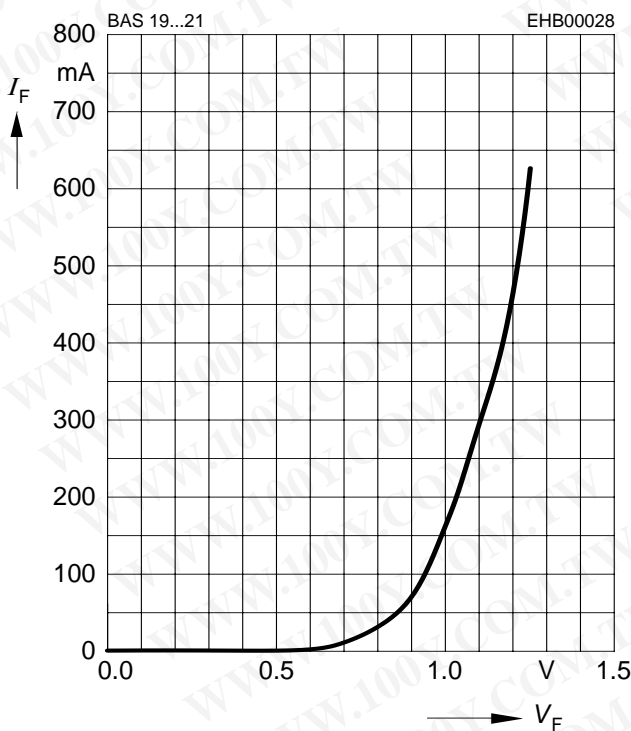

Forward current $I_F = f(T_S)$

BAS21-03W

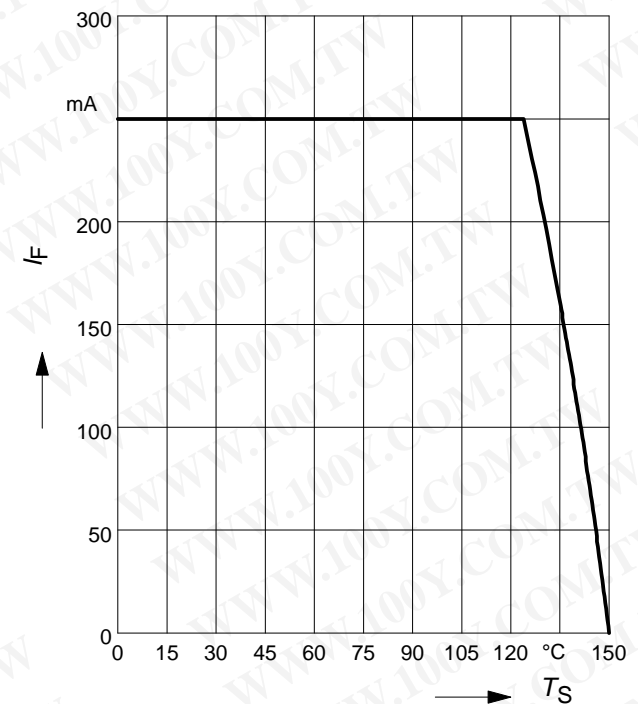

Forward current $I_F = f(T_S)$

BAS21U

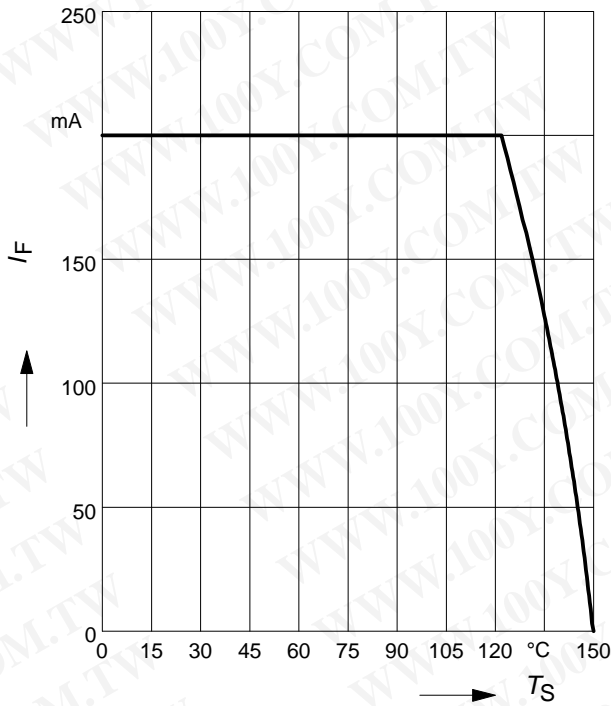

Permissible Puls Load $R_{thJS} = f(t_p)$

BAS21

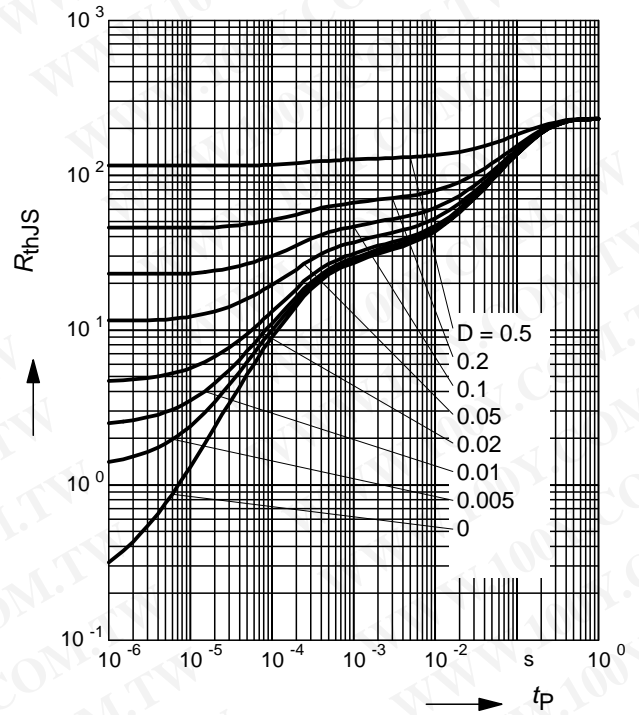

Permissible Pulse Load

$I_{Fmax}/I_{FDC} = f(t_p)$

BAS21

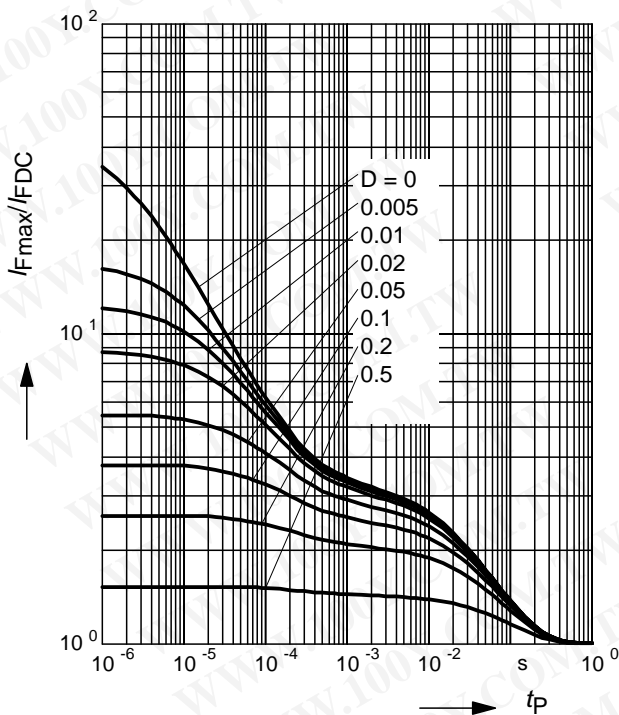

Permissible Puls Load $R_{thJS} = f(t_p)$

BAS21-03W

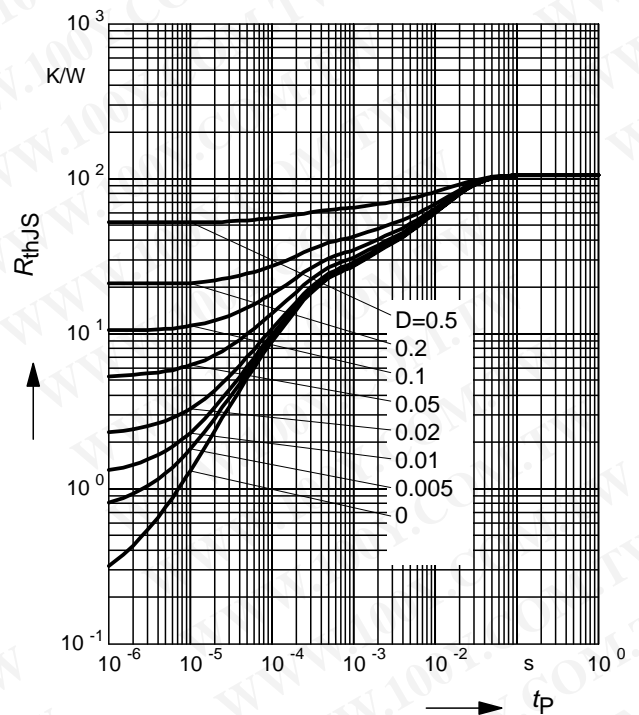

Permissible Pulse Load

$I_{Fmax} / I_{FDC} = f(t_p)$

BAS21-03W

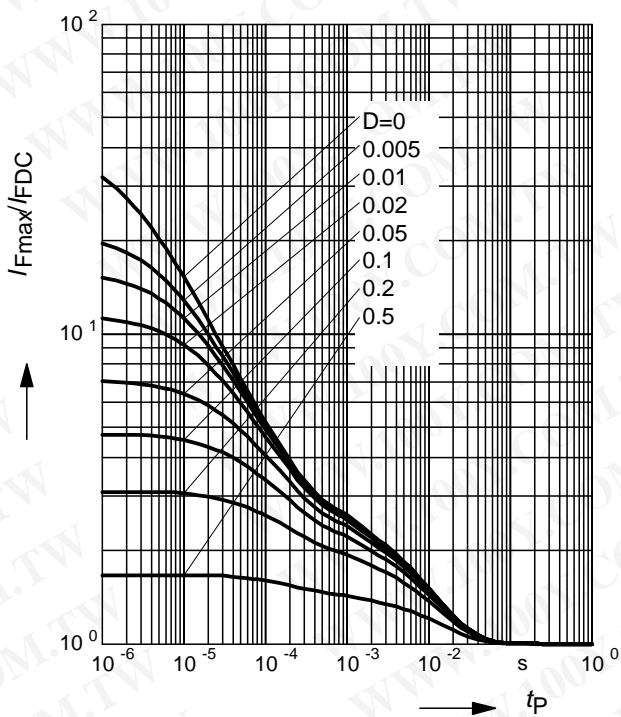

Permissible Puls Load $R_{thJS} = f(t_p)$

BAS21U

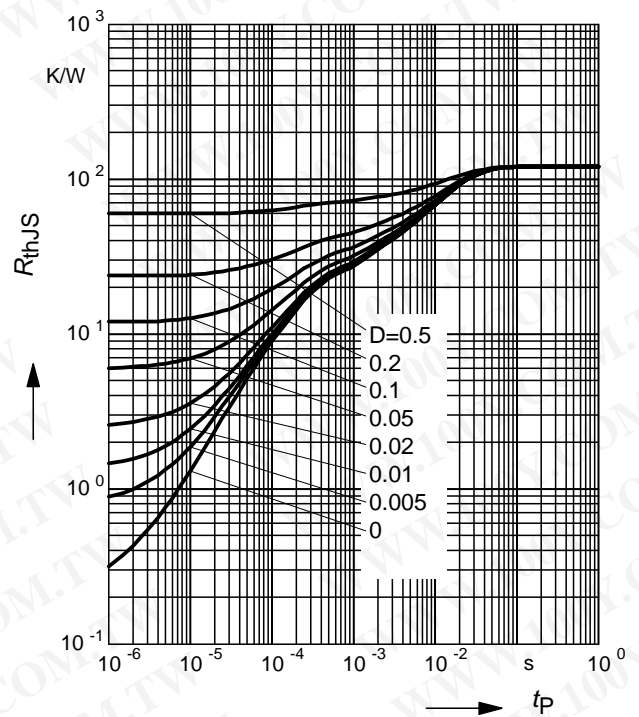

Permissible Pulse Load

$I_{Fmax} / I_{FDC} = f(t_p)$

BAS21U

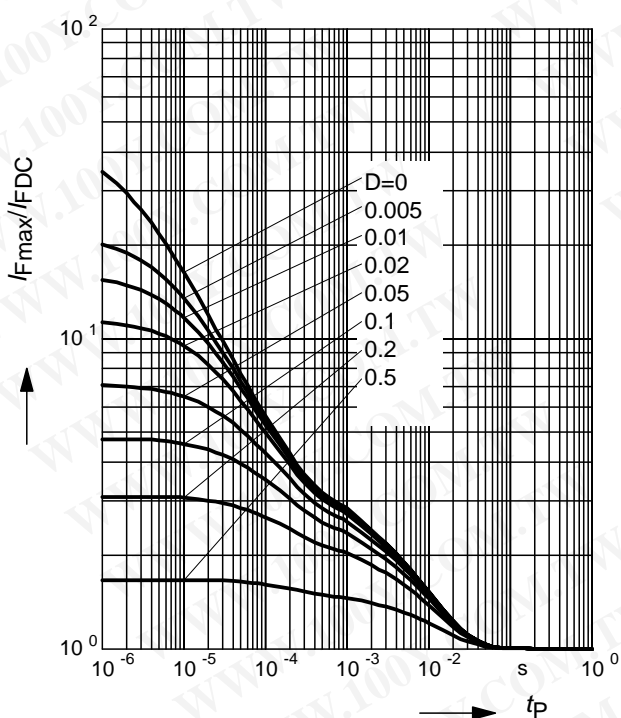

勝特力材料 886-3-5753170
 勝特力电子(上海) 86-21-34970699
 勝特力电子(深圳) 86-755-83298787
[Http://www.100y.com.tw](http://www.100y.com.tw)

Package Outline

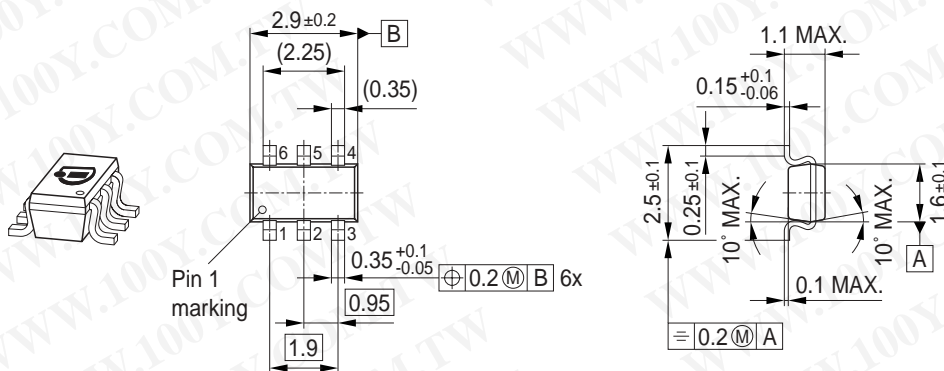

Foot Print

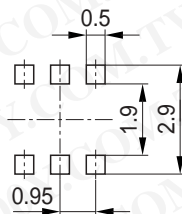

勝特力材料 886-3-5753170
 勝特力电子(上海) 86-21-34970699
 勝特力电子(深圳) 86-755-83298787
[Http://www.100y.com.tw](http://www.100y.com.tw)

Marking Layout

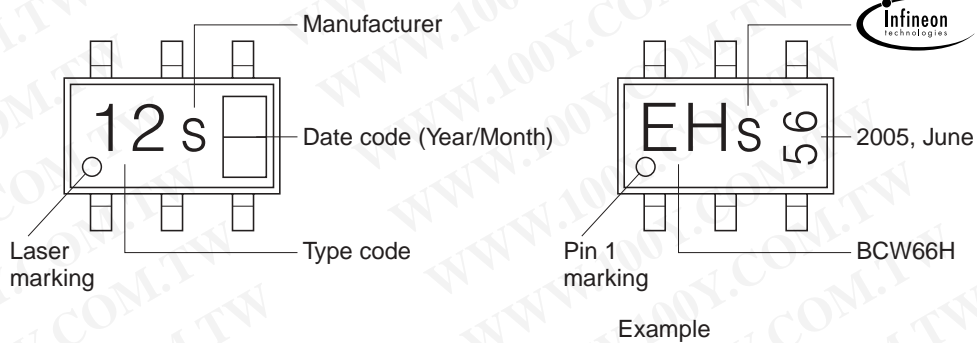

Standard Packing

Reel ø180 mm = 3.000 Pieces/Reel
 Reel ø330 mm = 10.000 Pieces/Reel

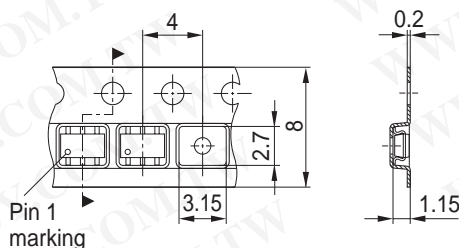

Package Outline

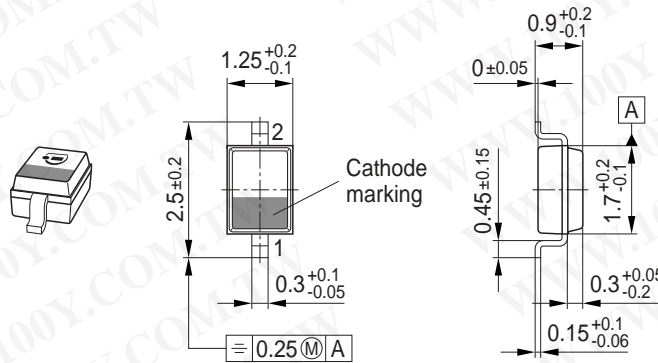

Foot Print

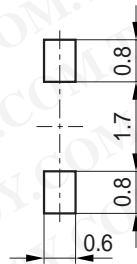

勝特力材料 886-3-5753170
 勝特力电子(上海) 86-21-34970699
 勝特力电子(深圳) 86-755-83298787
[Http://www.100y.com.tw](http://www.100y.com.tw)

Marking Layout

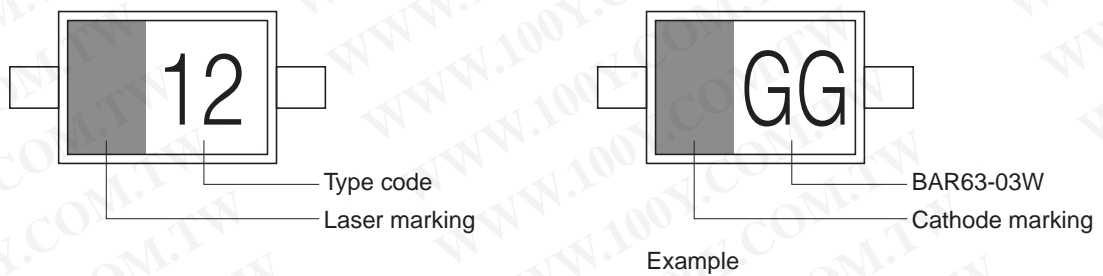

Standard Packing

Reel \varnothing 180 mm = 3.000 Pieces/Reel
 Reel \varnothing 330 mm = 10.000 Pieces/Reel

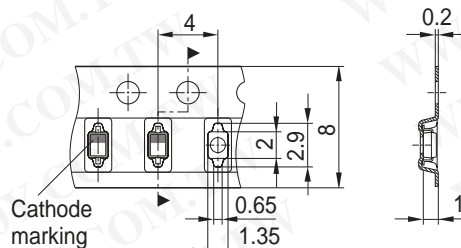

Package Outline

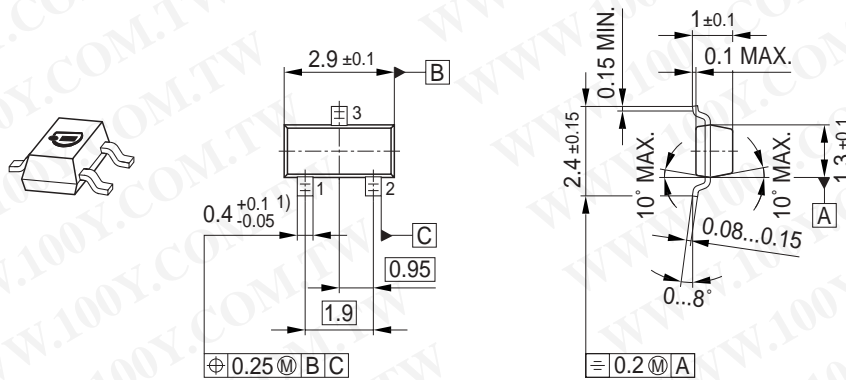

1) Lead width can be 0.6 max. in dambar area

Foot Print

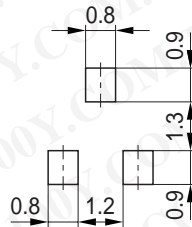

勝特力材料 886-3-5753170
 勝特力电子(上海) 86-21-34970699
 勝特力电子(深圳) 86-755-83298787
[Http://www.100y.com.tw](http://www.100y.com.tw)

Marking Layout

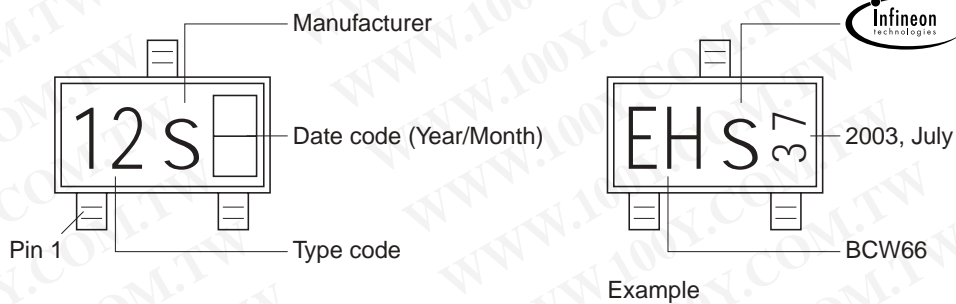

Standard Packing

Reel $\varnothing 180$ mm = 3.000 Pieces/Reel
 Reel $\varnothing 330$ mm = 10.000 Pieces/Reel

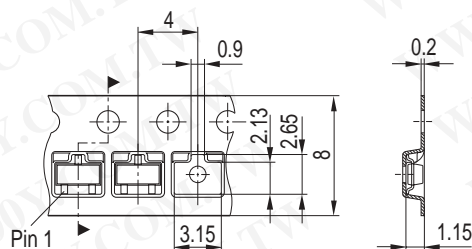

Published by Infineon Technologies AG,
St.-Martin-Strasse 53,
81669 München
© Infineon Technologies AG 2005.
All Rights Reserved.

勝特力材料 886-3-5753170
勝特力电子(上海) 86-21-34970699
勝特力电子(深圳) 86-755-83298787
[Http://www.100y.com.tw](http://www.100y.com.tw)

Attention please!

The information herein is given to describe certain components and shall not be considered as a guarantee of characteristics.

Terms of delivery and rights to technical change reserved.

We hereby disclaim any and all warranties, including but not limited to warranties of non-infringement, regarding circuits, descriptions and charts stated herein.

Information

For further information on technology, delivery terms and conditions and prices please contact your nearest Infineon Technologies Office (www.infineon.com).

Warnings

Due to technical requirements components may contain dangerous substances. For information on the types in question please contact your nearest Infineon Technologies Office.

Infineon Technologies Components may only be used in life-support devices or systems with the express written approval of Infineon Technologies, if a failure of such components can reasonably be expected to cause the failure of that life-support device or system, or to affect the safety or effectiveness of that device or system. Life support devices or systems are intended to be implanted in the human body, or to support and/or maintain and sustain and/or protect human life. If they fail, it is reasonable to assume that the health of the user or other persons may be endangered.