

30A, 50V, 0.065 Ohm, P-Channel Power MOSFETs

These are P-Channel power MOSFETs manufactured using the MegaFET process. This process, which uses feature sizes approaching those of LSI circuits, gives optimum utilization of silicon, resulting in outstanding performance. They were designed for use in applications such as switching regulators, switching converters, motor drivers, and relay drivers. These transistors can be operated directly from integrated circuits.

Formerly developmental type TA09834.

Ordering Information

| PART NUMBER | PACKAGE | BRAND |
|-------------|----------|----------|
| RFG30P05 | TO-247 | RFG30P05 |
| RFP30P05 | TO-220AB | RFP30P05 |
| RF1S30P05SM | TO-263AB | F1S30P05 |

NOTE: When ordering, use the entire part number. Add the suffix 9A to obtain the TO-263AB variant in tape and reel, i.e., RF1S30P05SM9A.

Features

- 30A, 50V
- $r_{DS(ON)} = 0.065\Omega$
- Temperature Compensating PSPICE® Model
- Peak Current vs Pulse Width Curve
- UIS Rating Curve
- 175°C Operating Temperature
- Related Literature
 - TB334 "Guidelines for Soldering Surface Mount Components to PC Boards"

Symbol

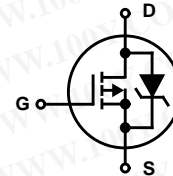

Packaging

JEDEC STYLE TO-247

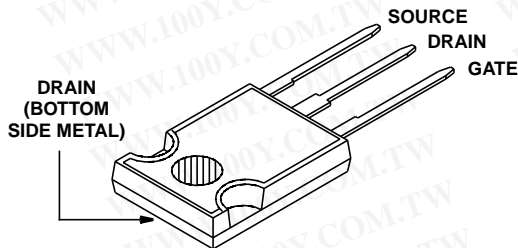

JEDEC TO-220AB

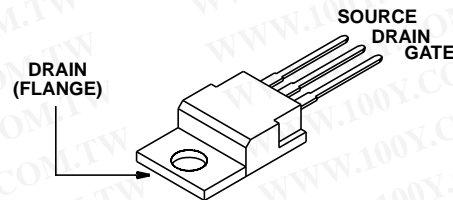

JEDEC TO-263AB

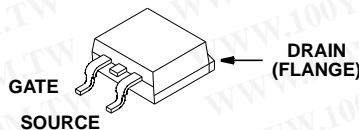

勝特力材料 886-3-5753170
 勝特力电子(上海) 86-21-34970699
 勝特力电子(深圳) 86-755-83298787
[Http://www.100y.com.tw](http://www.100y.com.tw)

Absolute Maximum Ratings $T_C = 25^{\circ}\text{C}$, Unless Otherwise Specified

| | RFG30P05, RFP30P05 RF1S30P05SM | UNITS |
|-------------------------------------------------------------------|-----------------------------------|-------------------------------|
| Drain to Source Voltage (Note 1) | V_{DSS} | -50 V |
| Drain to Gate Voltage ($R_{GS} = 20k\Omega$) (Note 1) | V_{DGR} | -50 V |
| Gate to Source Voltage | V_{GS} | ± 20 V |
| Continuous Drain Current | I_D | 30 A |
| Pulsed Drain Current (Note 3) (Figure 5) | I_{DM} | Refer to Peak Current Curve |
| Power Dissipation | P_D | 120 W |
| Linear Derating Factor | | 0.8 $W/^{\circ}\text{C}$ |
| Single Pulse Avalanche Rating (Figure 6) | E_{AS} | Refer to UIS Curve |
| Operating and Storage Temperature | T_J, T_{STG} | -55 to 175 $^{\circ}\text{C}$ |
| Maximum Temperature for Soldering | | |
| Leads at 0.063in (1.6mm) from Case for 10s. | T_L | 300 $^{\circ}\text{C}$ |
| Package Body for 10s, See Techbrief 334 | T_{pkg} | 260 $^{\circ}\text{C}$ |

CAUTION: Stresses above those listed in "Absolute Maximum Ratings" may cause permanent damage to the device. This is a stress only rating and operation of the device at these or any other conditions above those indicated in the operational sections of this specification is not implied.

NOTE:

- $T_J = 25^{\circ}\text{C}$ to 150°C .

Electrical Specifications $T_C = 25^{\circ}\text{C}$, Unless Otherwise Specified

| PARAMETER | SYMBOL | TEST CONDITIONS | MIN | TYP | MAX | UNITS | |
|-----------------------------------------|-------------------|-----------------------------------------------------------------------------------------------------------------------------|--------------------------------------------------------------------------------------------------------|------|-----------|----------------------|----|
| Drain to Source Breakdown Voltage | BV_{DSS} | $I_D = 250\mu\text{A}, V_{GS} = 0\text{V}$ | -50 | - | - | V | |
| Gate Threshold Voltage | $V_{GS(TH)}$ | $V_{GS} = V_{DS}, I_D = 250\mu\text{A}$ | -2 | - | -4 | V | |
| Zero Gate Voltage Drain Current | I_{DSS} | $V_{DS} = \text{Rated } BV_{DSS}, V_{GS} = 0\text{V}$ | - | - | -1 | μA | |
| | | $V_{DS} = 0.8 \times \text{Rated } BV_{DSS}, T_C = 150^{\circ}\text{C}$ | - | - | -25 | μA | |
| Gate to Source Leakage Current | I_{GSS} | $V_{GS} = \pm 20\text{V}$ | - | - | ± 100 | nA | |
| Drain to Source On Resistance | $r_{DS(ON)}$ | $I_D = 30\text{A}, V_{GS} = -10\text{V}$ (Figure 9) | - | - | 0.065 | Ω | |
| Turn-On Time | $t_{(ON)}$ | $V_{DD} = -25\text{V}, I_D = 15\text{A},$ $R_L = 1.67\Omega, V_{GS} = -10\text{V},$ $R_G = 6.25\Omega$ (Figure 13) | - | - | 80 | ns | |
| Turn-On Delay Time | $t_{d(ON)}$ | | - | 15 | - | ns | |
| Rise Time | t_r | | - | 23 | - | ns | |
| Turn-Off Delay Time | $t_{d(OFF)}$ | | - | 28 | - | ns | |
| Fall Time | t_f | | - | 18 | - | ns | |
| Turn-Off Time | $t_{(OFF)}$ | | - | - | 100 | ns | |
| Total Gate Charge | $Q_g(\text{TOT})$ | $V_{GS} = 0$ to -20V | $V_{DD} = -40\text{V},$ $I_D = 30\text{A}, R_L = 1.33\Omega,$ $I_{G(\text{REF})} = 1.6\text{mA}$ | - | 140 | 170 | nC |
| Gate Charge at -10V | $Q_g(-10)$ | $V_{GS} = 0$ to -10V | | - | 70 | 85 | nC |
| Threshold Gate Charge | $Q_g(\text{TH})$ | $V_{GS} = 0$ to -2V | | - | 5.5 | 6.6 | nC |
| Input Capacitance | C_{ISS} | $V_{DS} = -25\text{V}, V_{GS} = 0\text{V}$ $f = 1\text{MHz}$ (Figure 12) | - | 3200 | - | pF | |
| Output Capacitance | C_{OSS} | | - | 800 | - | pF | |
| Reverse Transfer Capacitance | C_{RSS} | | - | 175 | - | pF | |
| Thermal Resistance, Junction to Case | $R_{\theta JC}$ | | - | - | 1.25 | $^{\circ}\text{C/W}$ | |
| Thermal Resistance, Junction to Ambient | $R_{\theta JA}$ | TO-220, TO-263 | - | - | 62 | $^{\circ}\text{C/W}$ | |
| | | TO-247 | - | - | 30 | $^{\circ}\text{C/W}$ | |

Source to Drain Diode Specifications

| PARAMETER | SYMBOL | TEST CONDITIONS | MIN | TYP | MAX | UNITS |
|----------------------------------------|----------|---------------------------------------------------------------|-----|-----|------|-------|
| Source to Drain Diode Voltage (Note 2) | V_{SD} | $I_{SD} = -30\text{A}$ | - | - | -1.5 | V |
| Reverse Recovery Time | t_{rr} | $I_{SD} = -30\text{A}, dI_{SD}/dt = -100\text{A}/\mu\text{s}$ | - | - | 150 | ns |

NOTES:

- Pulsed: pulse duration = $300\mu\text{s}$ max, duty cycle = 2%.
- Repetitive rating: pulse width limited by maximum junction temperature. See Transient Thermal Impedance curve (Figure 3).

Typical Performance Curves Unless Otherwise Specified

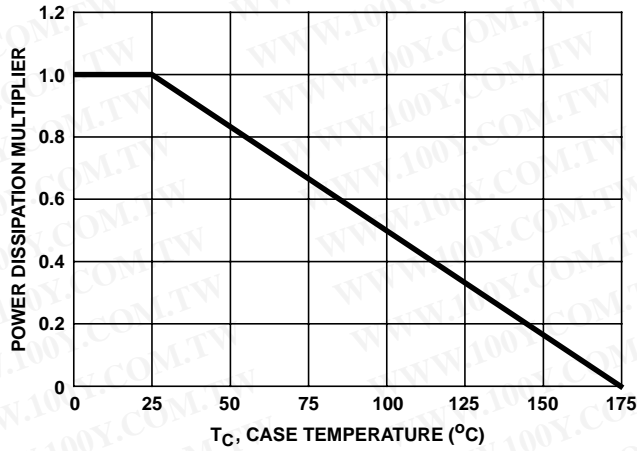

FIGURE 1. NORMALIZED POWER DISSIPATION vs CASE TEMPERATURE

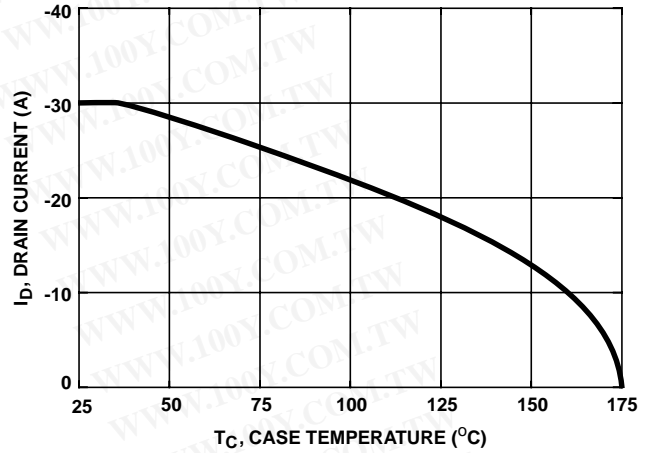

FIGURE 2. MAXIMUM CONTINUOUS DRAIN CURRENT vs CASE TEMPERATURE

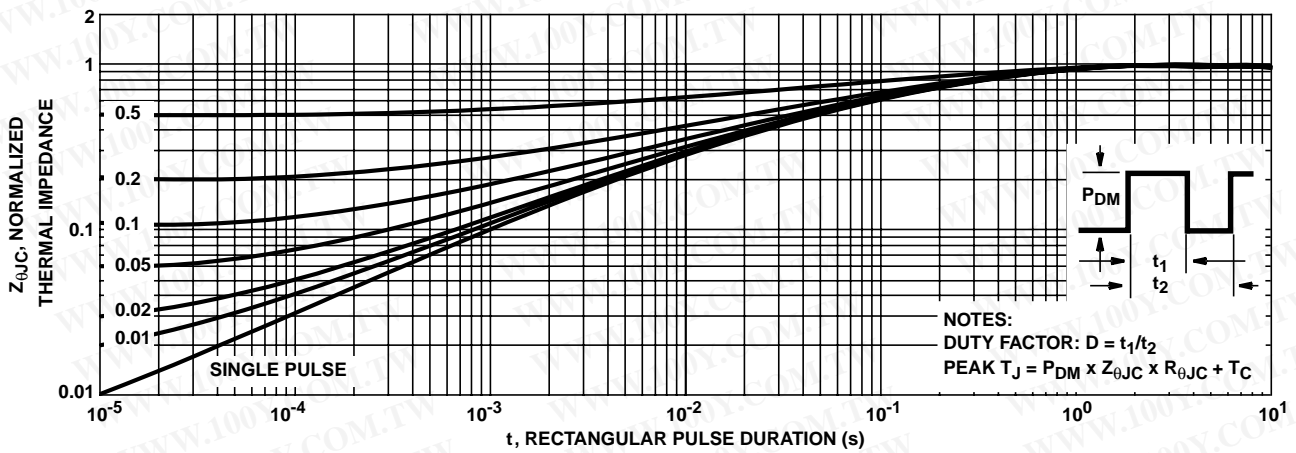

FIGURE 3. NORMALIZED MAXIMUM TRANSIENT THERMAL IMPEDANCE

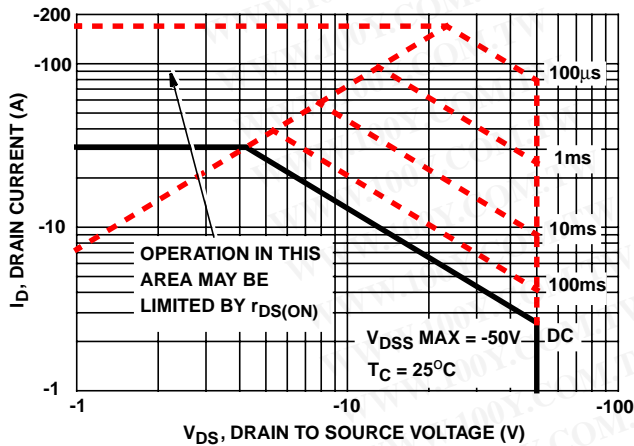

FIGURE 4. FORWARD BIAS SAFE OPERATING AREA

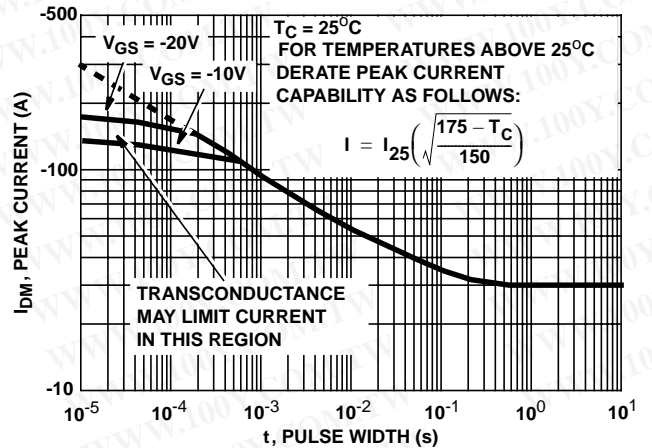
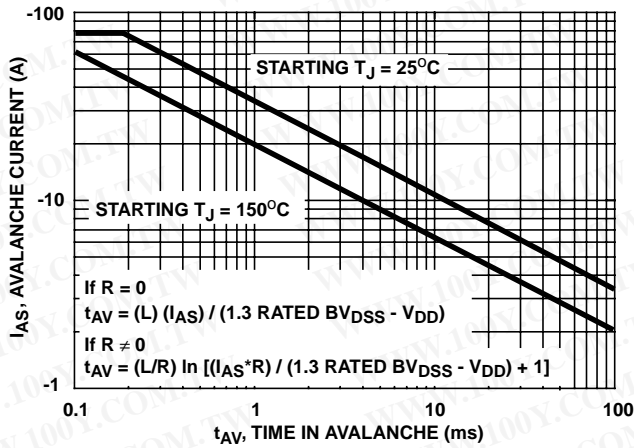

FIGURE 5. PEAK CURRENT CAPABILITY

Typical Performance Curves Unless Otherwise Specified (Continued)



NOTE: Refer to Intersil Application Notes AN9321 and AN9322.

FIGURE 6. UNCLAMPED INDUCTIVE SWITCHING CAPABILITY

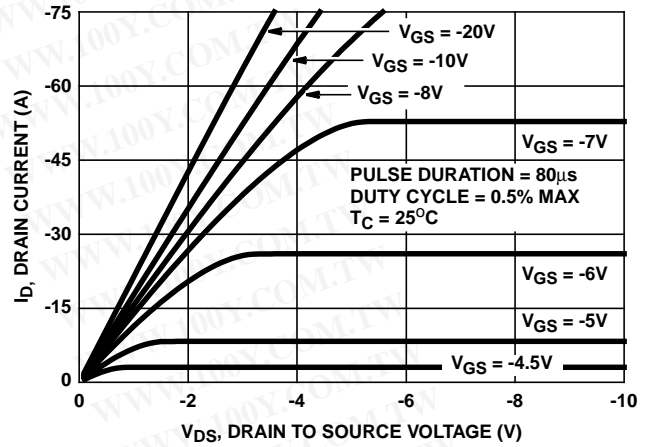

FIGURE 7. SATURATION CHARACTERISTICS

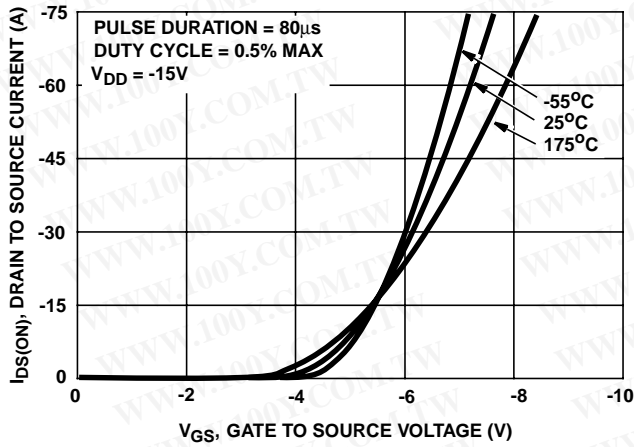

FIGURE 8. TRANSFER CHARACTERISTICS

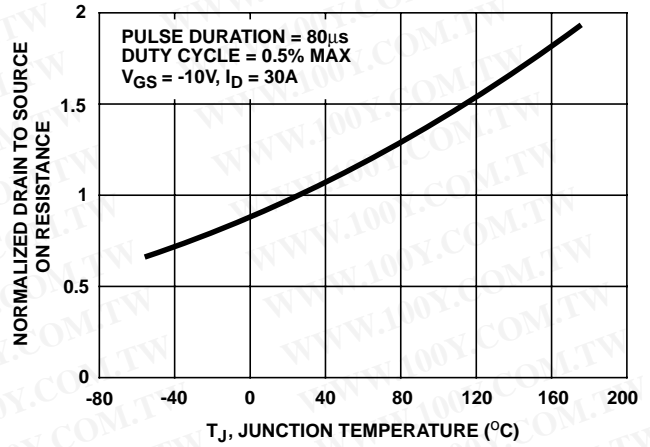

FIGURE 9. NORMALIZED DRAIN TO SOURCE ON RESISTANCE vs JUNCTION TEMPERATURE

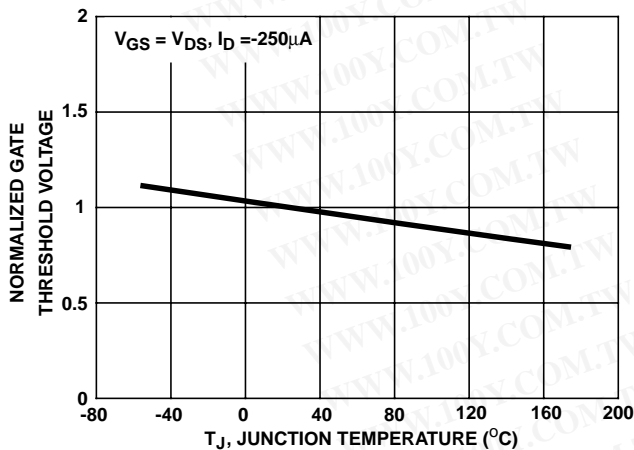

FIGURE 10. NORMALIZED GATE THRESHOLD VOLTAGE vs JUNCTION TEMPERATURE

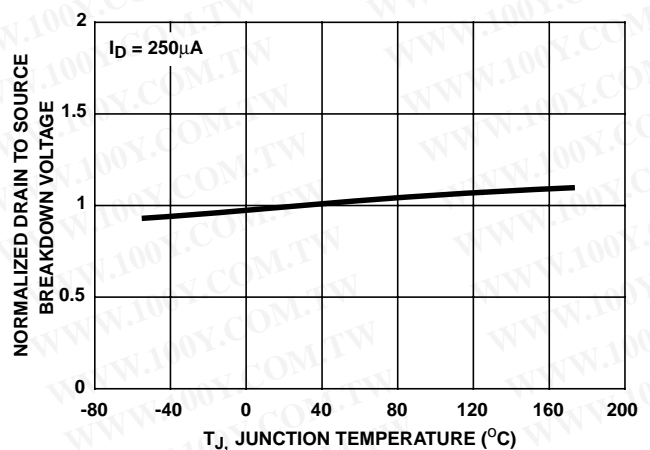

FIGURE 11. NORMALIZED DRAIN TO SOURCE BREAKDOWN VOLTAGE vs JUNCTION TEMPERATURE

Typical Performance Curves Unless Otherwise Specified (Continued)

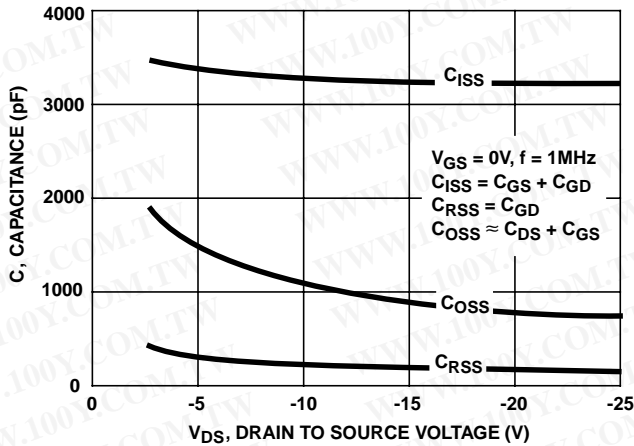
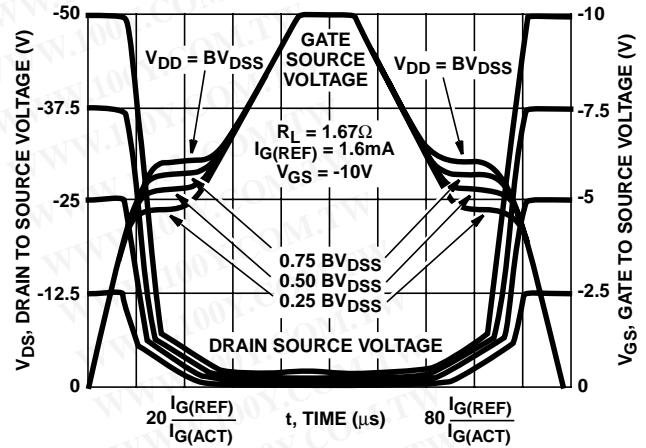

FIGURE 12. CAPACITANCE vs DRAIN TO SOURCE VOLTAGE



NOTE: Refer to Intersil Application Notes AN7254 and AN7260.

FIGURE 13. NORMALIZED SWITCHING WAVEFORMS FOR CONSTANT GATE CURRENT

Test Circuits and Waveforms

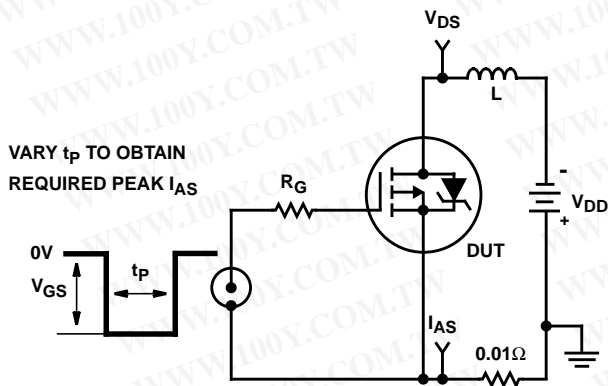

FIGURE 14. UNCLAMPED ENERGY TEST CIRCUIT

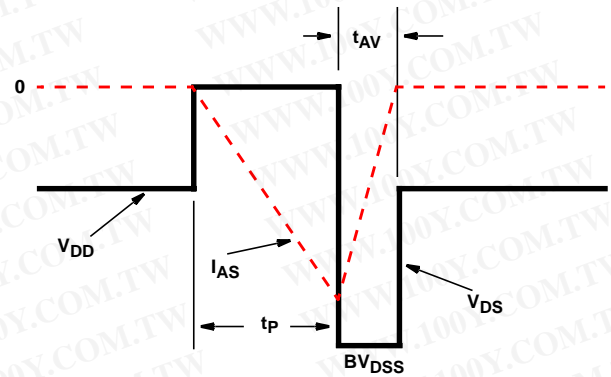

FIGURE 15. UNCLAMPED ENERGY WAVEFORMS

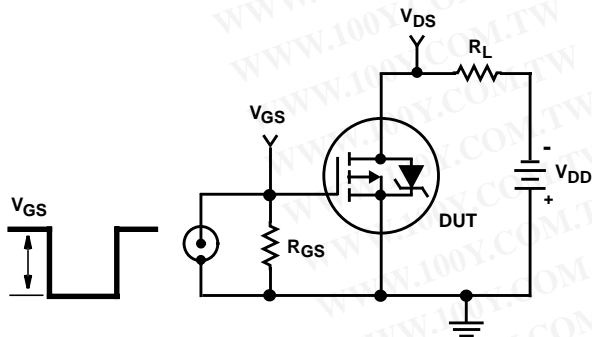

FIGURE 16. SWITCHING TIME TEST CIRCUIT

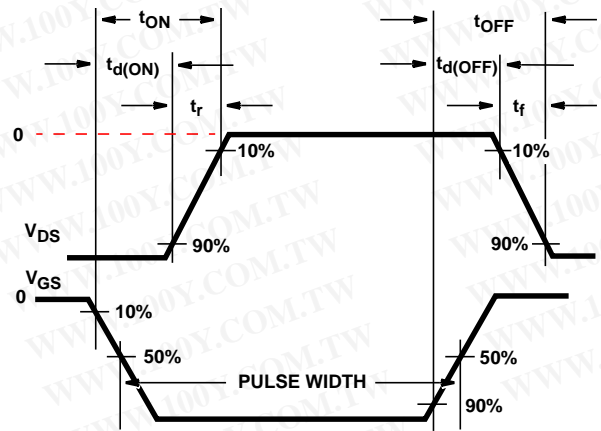

FIGURE 17. RESISTIVE SWITCHING WAVEFORMS

Test Circuits and Waveforms (Continued)

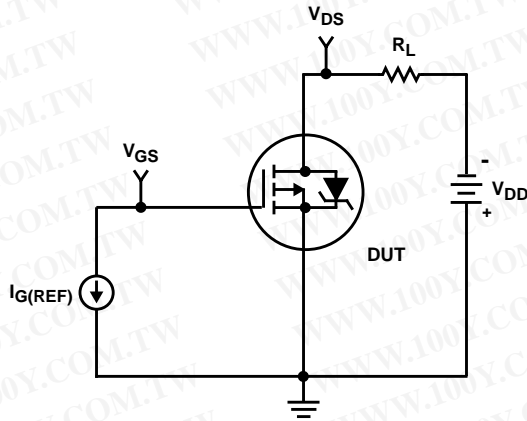

FIGURE 18. GATE CHARGE TEST CIRCUIT

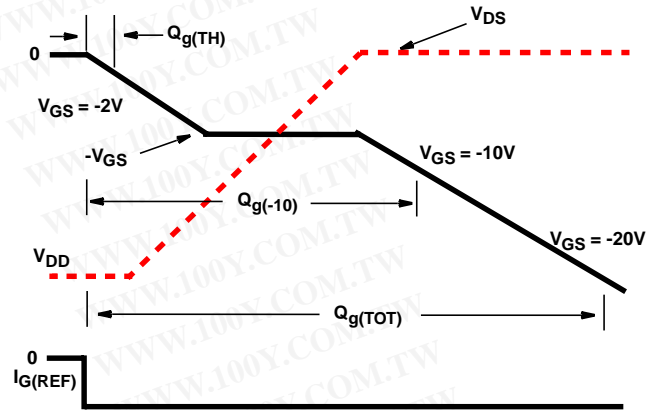

FIGURE 19. GATE CHARGE WAVEFORMS

勝特力材料 886-3-5753170
 勝特力电子(上海) 86-21-34970699
 勝特力电子(深圳) 86-755-83298787
[Http://www.100y.com.tw](http://www.100y.com.tw)

PSpICE Electrical Model

.SUBCKT RFP30P05 2 1 3;
REV 8/21/94

CA 12 8 3.23e-9
CB 15 14 3.23e-9
CIN 6 8 3.08e-9

DBODY 5 7 DBDMOD
DBREAK 7 11 DBKMOD
DPLCAP 10 6 DPLCAPMOD

EBREAK 5 11 17 18 -77.3
EDS 14 8 5 8 1
EGS 13 8 6 8 1
ESG 5 10 8 6 1
EVTO 20 6 8 18 1

IT 8 17 1

LDRAIN 2 5 1e-9
LGATE 1 9 4.92e-9
LSOURCE 3 7 4.60e-9

MOS1 16 6 8 8 MOSMOD M=0.99
MOS2 16 21 8 8 MOSMOD M=0.01

RBREAK 17 18 RBKMOD 1
RDRAIN 50 16 RDSMOD 39.85e-3
RGATE 9 20 2.34
RIN 6 8 1e9
RSCL1 5 51 RSCLMOD 1e-6
RSCL2 5 50 1e3
RSOURCE 8 7 RDSMOD 2.56e-3
RVTO 18 19 RVTOMOD 1

S1A 6 12 13 8 S1AMOD
S1B 13 12 13 8 S1BMOD
S2A 6 15 14 13 S2AMOD
S2B 13 15 14 13 S2BMOD

VBAT 8 19 DC 1
VTO 21 6 -0.81

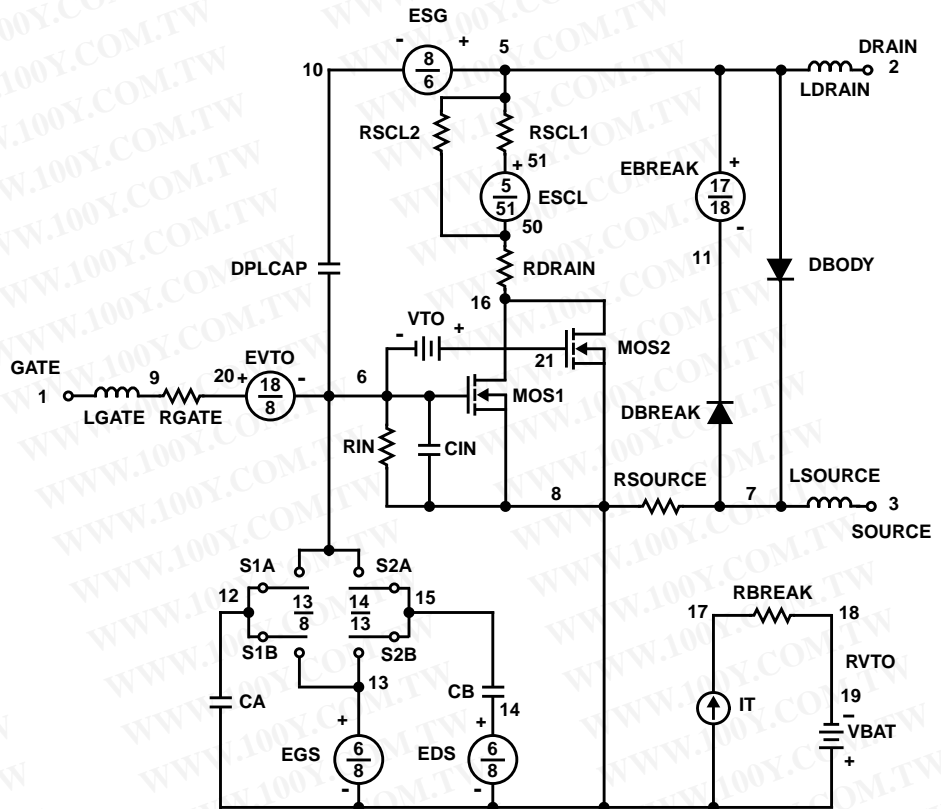

ESCL 51 50 VALUE={(V(5,51)/ABS(V(5,51)))*(PWR(V(5,51)*1e6/114,5))}

.MODEL DBDMOD D (IS=4.7e-13 RS=1.31e-2 TRS1=1.39e-4 TRS2=-4.77e-6 CJO=2.85e-9 TT=8.81e-8)
.MODEL DBKMOD D (RS=2.23e-1 TRS1=1.97e-3 TRS2=-2.37e-5)
.MODEL DPLCAPMOD D (CJO=0.78e-9 IS=1e-30 N=10)
.MODEL MOSMOD PMOS (VTO=-3.75 KP=10.83 IS=1e-30 N=10 TOX=1 L=1u W=1u)
.MODEL RBKMOD RES (TC1=9.08e-4 TC2=-1.72e-6)
.MODEL RDSMOD RES (TC1=5.01e-3 TC2=1.02e-5)
.MODEL RSCLMOD RES (TC1=2.09e-3 TC2=5.88e-7)
.MODEL RVTOMOD RES (TC1=-2.99e-3 TC2=1.40e-6)
.MODEL S1AMOD VSWITCH (RON=1e-5 ROFF=0.1 VON=3.4 VOFF=1.4)
.MODEL S1BMOD VSWITCH (RON=1e-5 ROFF=0.1 VON=1.4 VOFF=3.4)
.MODEL S2AMOD VSWITCH (RON=1e-5 ROFF=0.1 VON=1.2 VOFF=-3.8)
.MODEL S2BMOD VSWITCH (RON=1e-5 ROFF=0.1 VON=-3.8 VOFF=1.2)

.ENDS

NOTE: For further discussion of the PSpICE model consult **A New PSpICE Sub-circuit for the Power MOSFET Featuring Global Temperature Options**; authors, William J. Hepp and C. Frank Wheatley.

勝特力材料 886-3-5753170
 勝特力电子(上海) 86-21-34970699
 勝特力电子(深圳) 86-755-83298787
[Http://www.100y.com.tw](http://www.100y.com.tw)