

# N-CHANNEL MOS FIELD EFFECT POWER TRANSISTOR

## 2SK700

**DESCRIPTION** The 2SK700 is N-Channel MOS Field Effect Power Transistor designed for solenoid, motor and lamp driver.

- FEATURES**
- 4 V Gate Drive – Logic level –
  - Low  $R_{DS(on)}$
  - No Second Breakdown

**ABSOLUTE MAXIMUM RATINGS**

- Maximum Temperatures
- Storage Temperature . . . . . -55 to +150 °C
  - Junction Temperature . . . . . 150 °C Maximum
- Maximum Power Dissipations
- Total Power Dissipation . . . . . 1.3 W
  - Total Power Dissipation ( $T_C = 25\text{ °C}$ ) . . . . . 15 W
- Maximum Voltages and Currents ( $T_a = 25\text{ °C}$ )
- $V_{DSS}$  Drain to Source Voltage . . . . . 80 V
  - $V_{GSS}$  Gate to Source Voltage . . . . .  $\pm 20$  V
  - $I_{D(DC)}$  Drain Current (DC) . . . . .  $\pm 2$  A
  - $I_{D(pulse)}$  Drain Current (pulse)\* . . . . .  $\pm 6$  A
- \* PW  $\leq 300\ \mu s$ , Duty Cycle  $\leq 10\%$

**PACKAGE DIMENSIONS**  
in millimeters (inches)

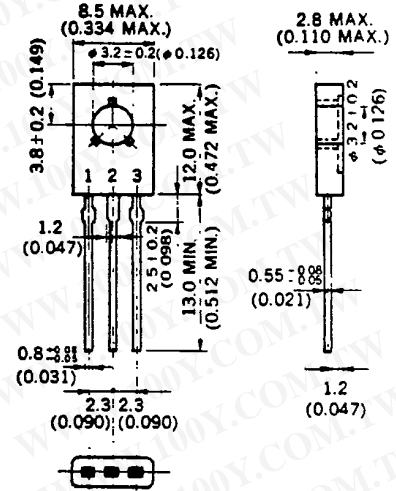

**ELECTRICAL CHARACTERISTICS ( $T_a = 25\text{ °C}$ )**

SYMBOL	CHARACTERISTIC	MIN.	TYP	MAX.	UNIT	TEST CONDITIONS
$R_{DS(on)}$	Drain to Source On-State Resistance		0.6	0.8	$\Omega$	$V_{GS} = 10\text{ V}$ , $I_D = 1\text{ A}$
$R_{DS(on)}$	Drain to Source On-State Resistance		0.8	1.0	$\Omega$	$V_{GS} = 4\text{ V}$ , $I_D = 1\text{ A}$
$V_{GS(off)}$	Gate to Source Cutoff Voltage	1.0		2.5	V	$V_{DS} = 10\text{ V}$ , $I_D = -1\text{ mA}$
$Y_{fs}$	Forward Transfer Admittance	0.5			S	$V_{DS} = 10\text{ V}$ , $I_D = 1\text{ A}$
$I_{DSS}$	Drain Leakage Current			10	$\mu A$	$V_{DS} = 80\text{ V}$ , $V_{GS} = 0$
$I_{GSS}$	Gate to Source Leakage Current			$\pm 100$	nA	$V_{GS} = \pm 20\text{ V}$ , $V_{DS} = 0$
$C_{iss}$	Input Capacitance		200		pF	$V_{DS} = 10\text{ V}$ $V_{GS} = 0$ $f = 1\text{ MHz}$
$C_{oss}$	Output Capacitance		70		pF	
$C_{rss}$	Reverse Transfer Capacitance		15		pF	
$t_{d(on)}$	Turn-On Delay Time		45		ns	$I_D = 1\text{ A}$ , $V_{CC} = 50\text{ V}$ $R_L = 50\ \Omega$ $R_{in} = 10\ \Omega$
$t_r$	Rise Time		40		ns	
$t_{d(off)}$	Turn-Off Delay Time		450		ns	
$t_f$	Fall Time		110		ns	

NEC cannot assume any responsibility for any circuits shown or represent that they are free from patent infringement

TYPICAL CHARACTERISTICS ( $T_B = 25^\circ\text{C}$ )

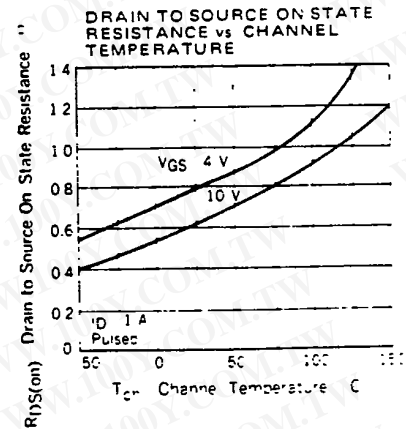
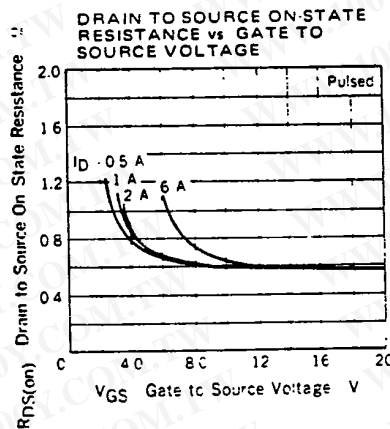
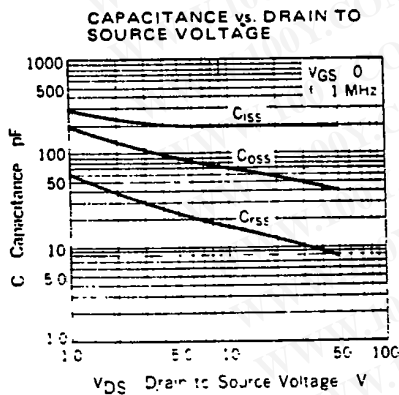
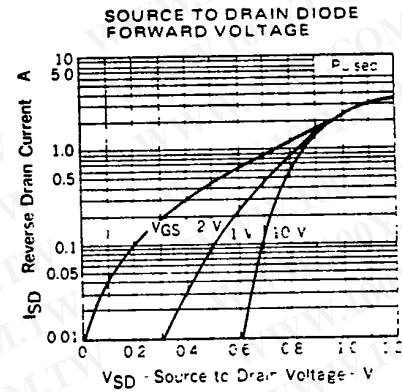
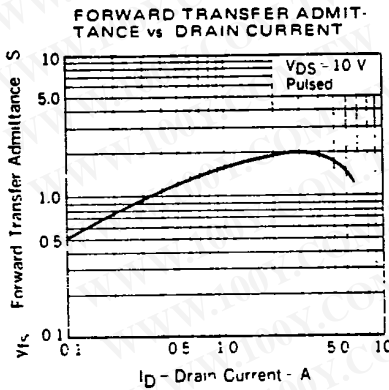
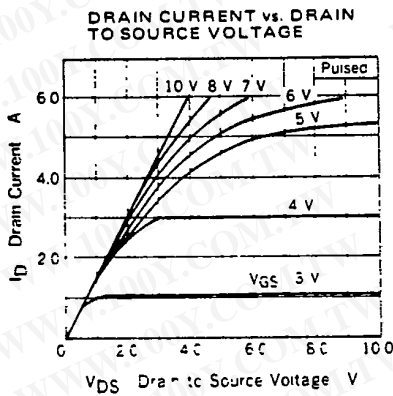
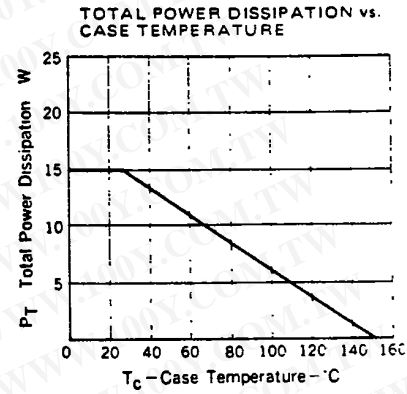
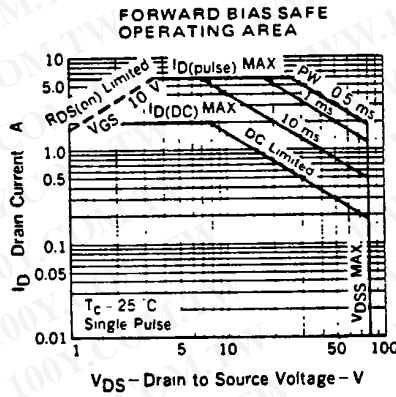
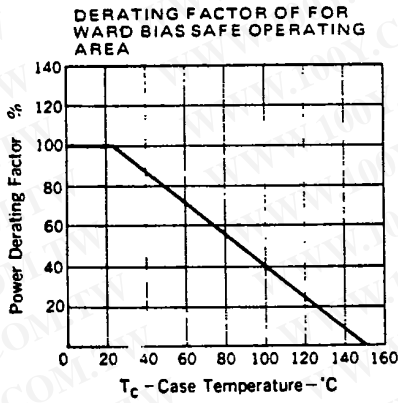

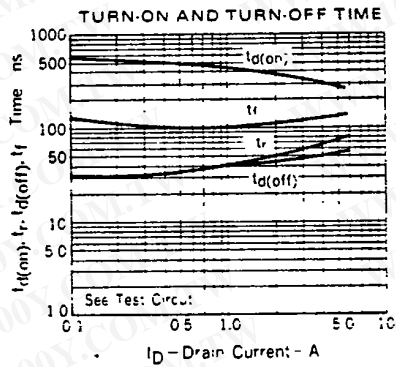
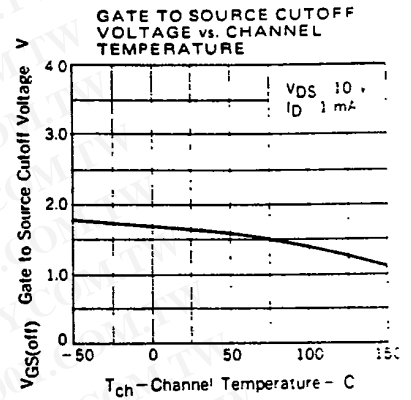
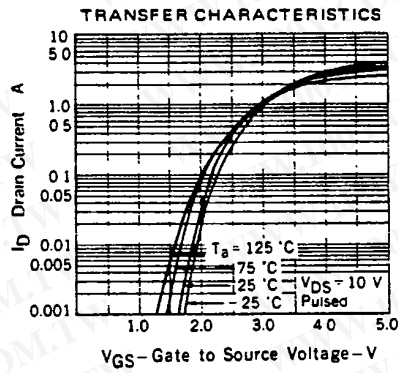
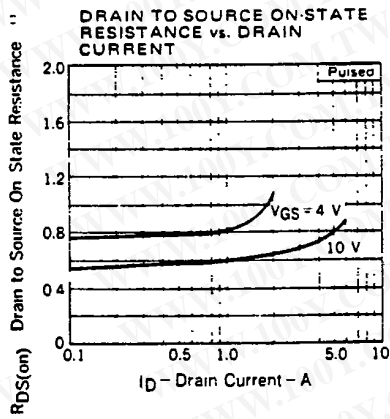

**TURN-ON AND TURN-OFF TIME TEST CIRCUIT**

