

SKKT 106, SKKT 106B, SKKH 106

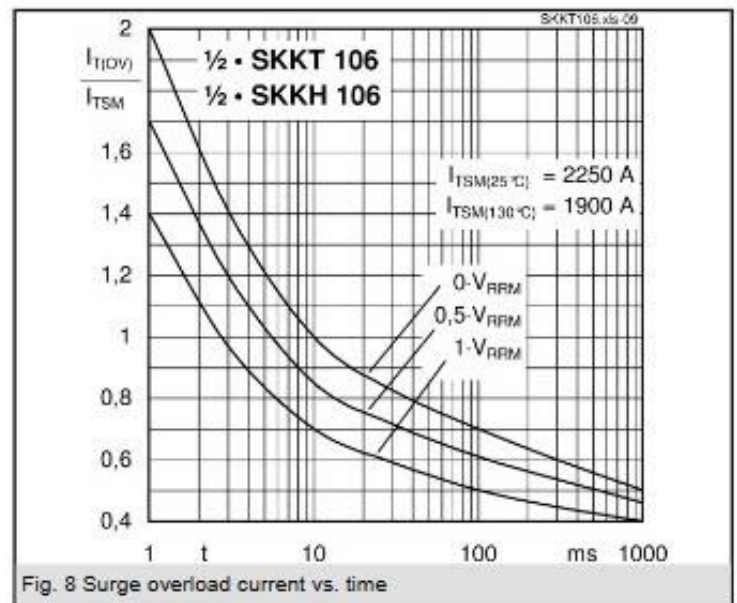

勝特力電材超市-龍山店 886-3-5773766
 勝特力電材超市-光復店 886-3-5729570
 勝特力電子(上海) 86-21-34970699
 勝特力電子(深圳) 86-755-83298787
<http://www.100y.com.tw>

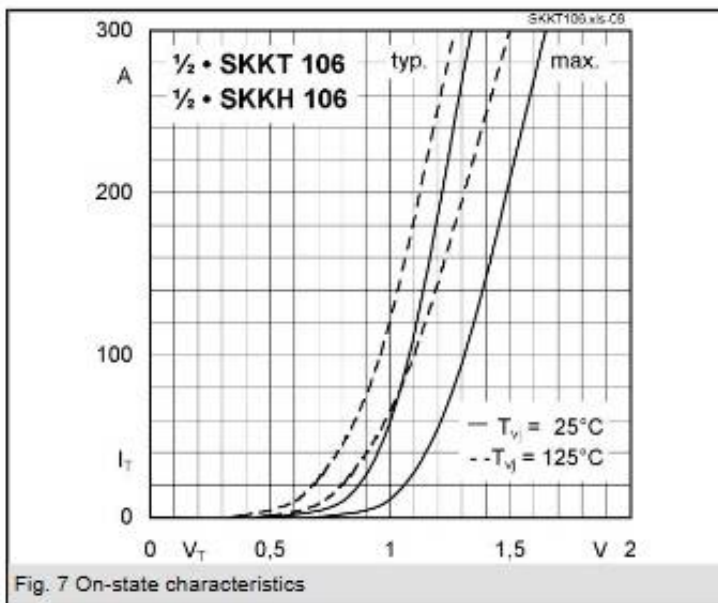
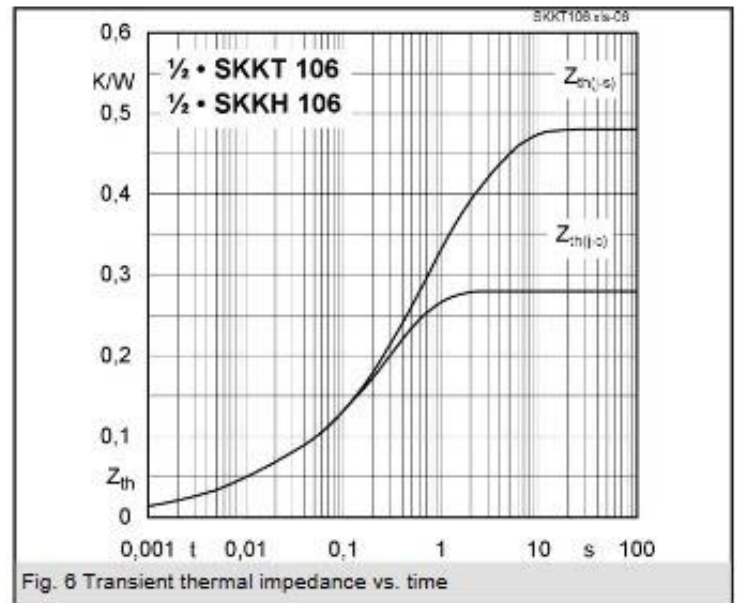
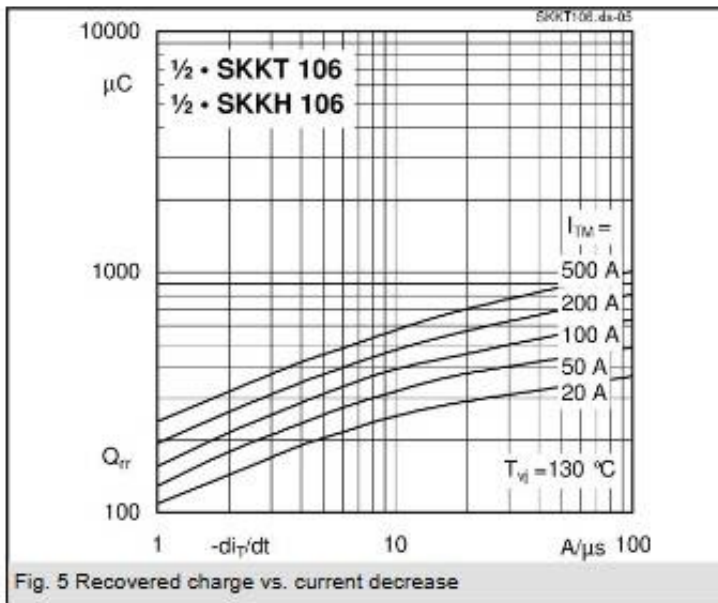
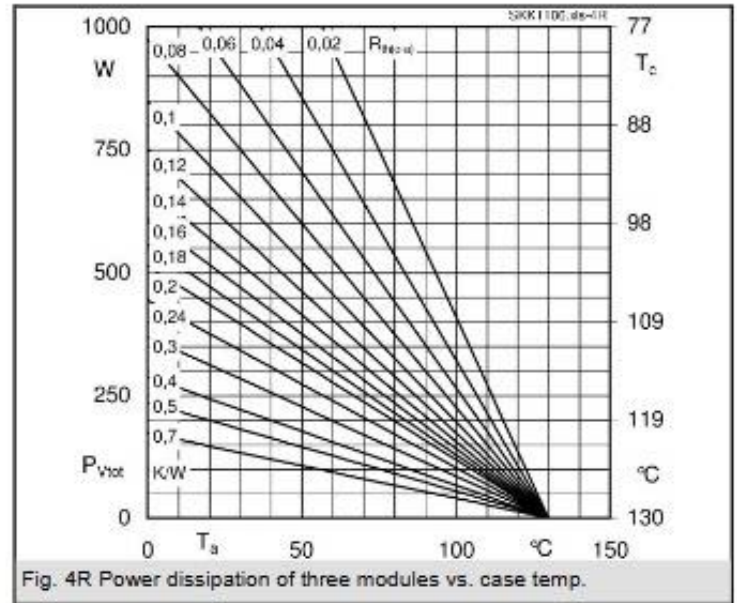
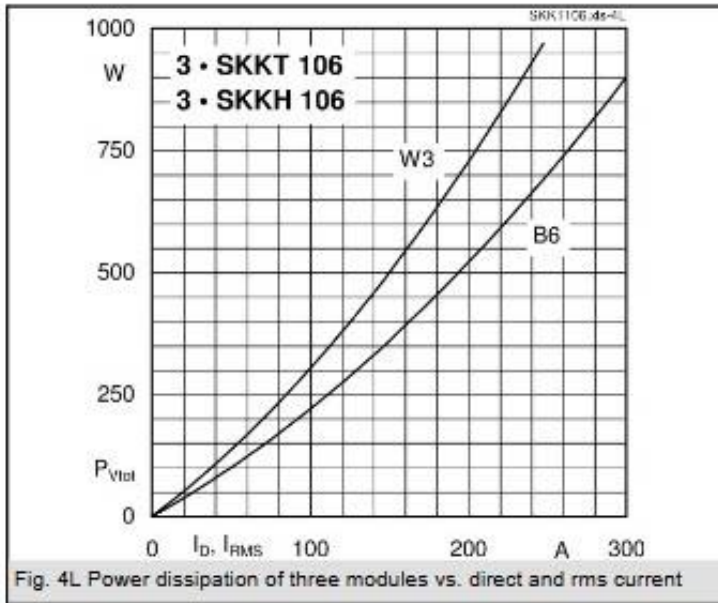
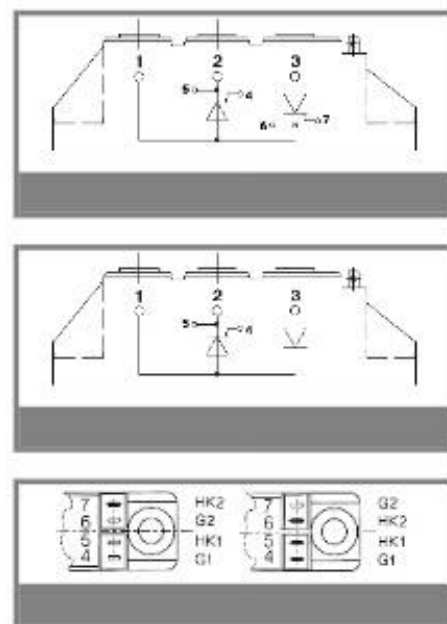
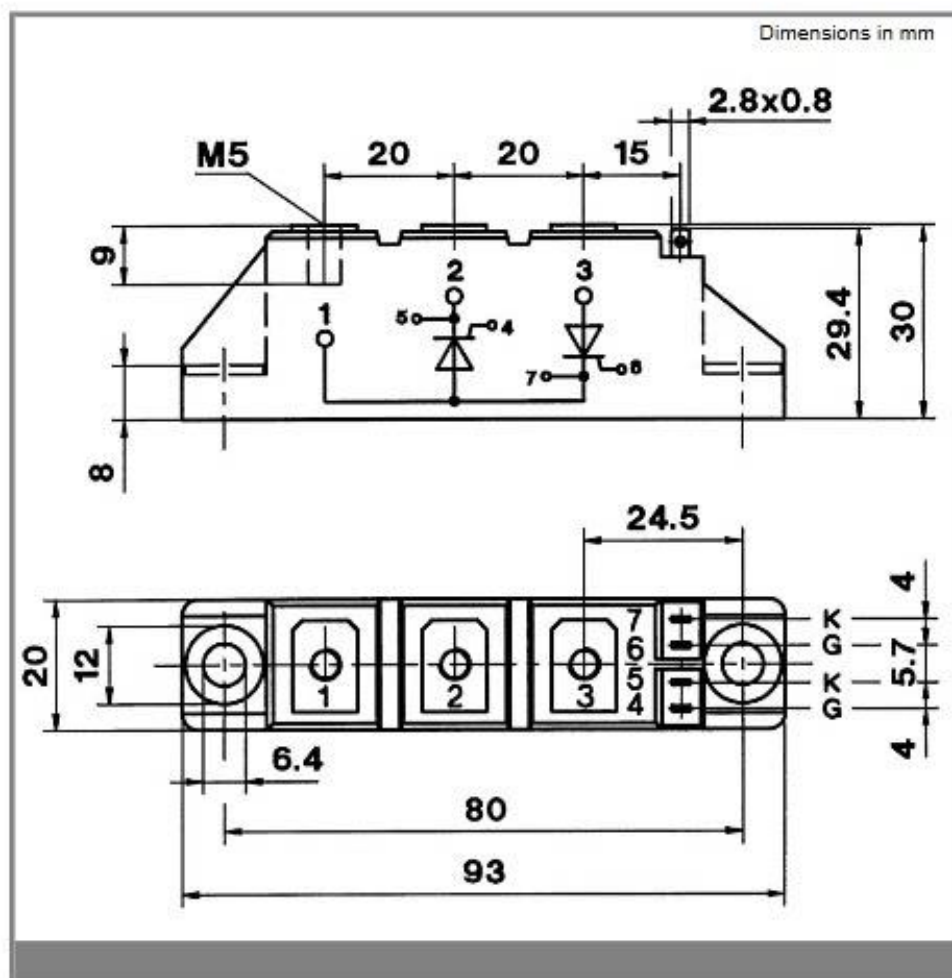
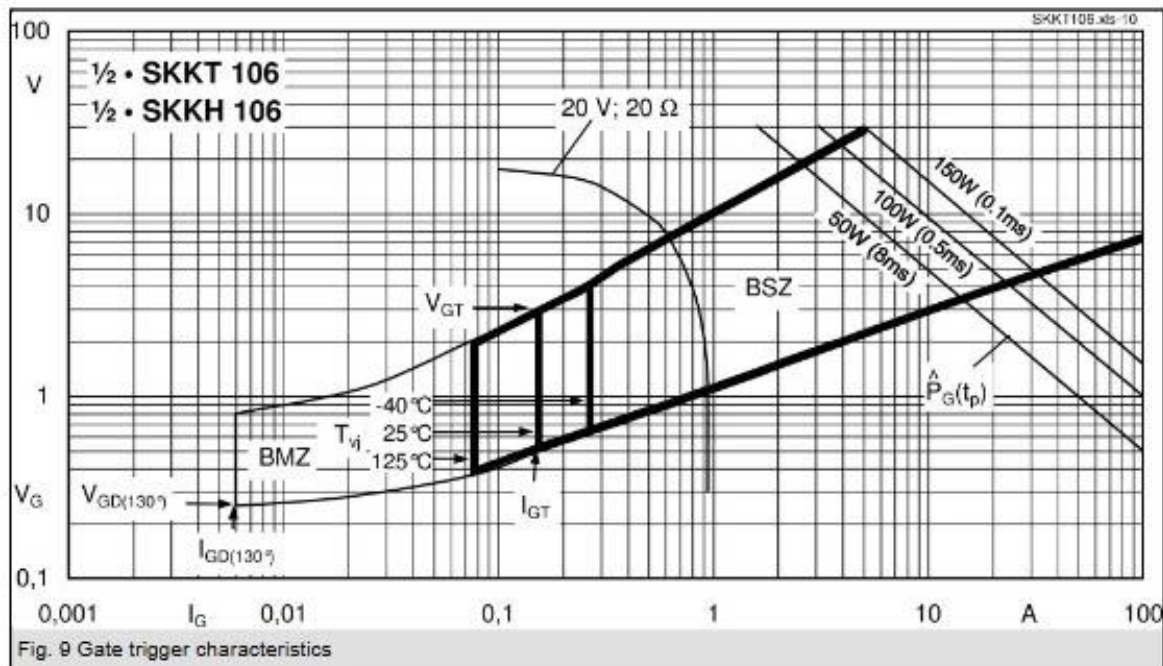

This technical information specifies semiconductor devices but promises no characteristics. No warranty or guarantee expressed or implied is made regarding delivery, performance or suitability.

型號：SKKT106/08E

08：代表电压等级，表示该模块的额定电压为 800V。

E：代表 dv/dt 耐量等级（即电压上升率），表示该模块的临界电压上升率为 1000 V/ μ s。

勝特力電材超市-龍山店 886-3-5773766
勝特力電材超市-光復店 886-3-5729570
勝特力电子(上海) 86-21-34970699
勝特力电子(深圳) 86-755-83298787
<http://www.100y.com.tw>