



TIP102 TIP107

COMPLEMENTARY SILICON POWER DARLINGTON TRANSISTORS

- STMicroelectronics PREFERRED SALESTYPES
- COMPLEMENTARY PNP - NPN DEVICES
- INTEGRATED ANTIPARALLEL COLLECTOR-EMITTER DIODE

APPLICATIONS

- LINEAR AND SWITCHING INDUSTRIAL EQUIPMENT
- AUDIO POWER AMPLIFIER
- GENERAL POWER SWITCHING
- DC-AC CONVERTER
- EASY DRIVER FOR LOW VOLTAGE DC MOTOR

DESCRIPTION

The TIP102 is a silicon Epitaxial-Base NPN power transistor in monolithic Darlington configuration mounted in TO-220 plastic package. It is intended for use in power linear and switching applications.

The complementary PNP type is TIP107.

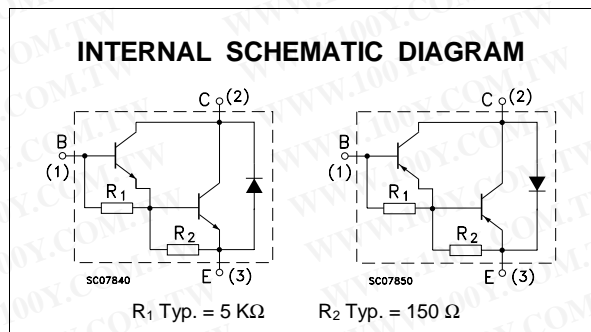
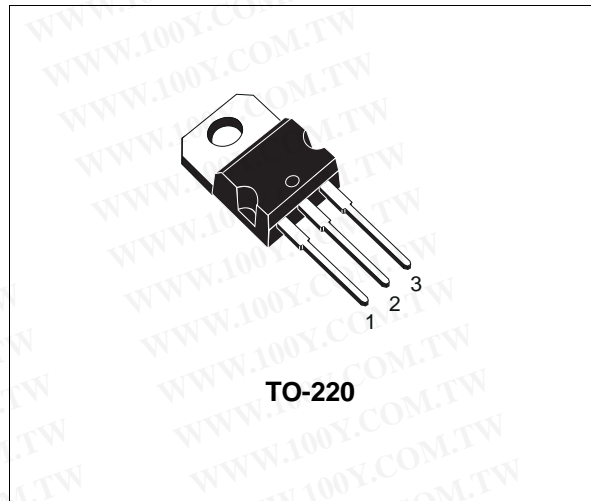

勝特力材料 886-3-5753170
 勝特力电子(上海) 86-21-54151736
 勝特力电子(深圳) 86-755-83298787
[Http://www.100y.com.tw](http://www.100y.com.tw)

ABSOLUTE MAXIMUM RATINGS

Symbol	Parameter	Value		Unit
		NPN	TIP102	
V _{CBO}	Collector-Base Voltage (I _E = 0)		100	V
V _{CEO}	Collector-Emitter Voltage (I _B = 0)		100	V
V _{EBO}	Emitter-Base Voltage (I _C = 0)		5	V
I _C	Collector Current		8	A
I _{CM}	Collector Peak Current		15	A
I _B	Base Current		1	A
P _{tot}	Total Dissipation at T _{case} ≤ 25 °C T _{amb} ≤ 25 °C		80	W
			2	W
T _{stg}	Storage Temperature		-65 to 150	°C
T _j	Max. Operating Junction Temperature		150	°C

* For PNP types voltage and current values are negative.

TIP102 / TIP107

THERMAL DATA

R _{thj-case}	Thermal Resistance Junction-case	Max	1.56	°C/W
R _{thj-amb}	Thermal Resistance Junction-ambient	Max	62.5	°C/W

ELECTRICAL CHARACTERISTICS (T_{case} = 25 °C unless otherwise specified)

Symbol	Parameter	Test Conditions	Min.	Typ.	Max.	Unit
I _{CEO}	Collector Cut-off Current (I _B = 0)	V _{CE} = 50 V			50	μA
I _{CBO}	Collector Cut-off Current (I _E = 0)	V _{CB} = 100 V			50	μA
I _{EBO}	Emitter Cut-off Current (I _C = 0)	V _{EB} = 5 V			8	mA
V _{CEO(sus)} *	Collector-Emitter Sustaining Voltage (I _B = 0)	I _C = 30 mA	100			V
V _{CE(sat)} *	Collector-Emitter Saturation Voltage	I _C = 3 A I _C = 8 A			2 2.5	V V
V _{BE} *	Base-Emitter Voltage	I _C = 8 A V _{CE} = 4 V			2.8	V
h _{FE} *	DC Current Gain	I _C = 3 A I _C = 8 A	1000 200		20000	
V _F *	Forward Voltage of Commutation Diode (I _B = 0)	I _F = - I _C = 10 A			2.8	V

* Pulsed: Pulse duration = 300 μs, duty cycle 1.5 %
For PNP types voltage and current values are negative.

勝特力材料 886-3-5753170
勝特力电子(上海) 86-21-54151736
勝特力电子(深圳) 86-755-83298787
[Http://www.100y.com.tw](http://www.100y.com.tw)

Safe Operating Area

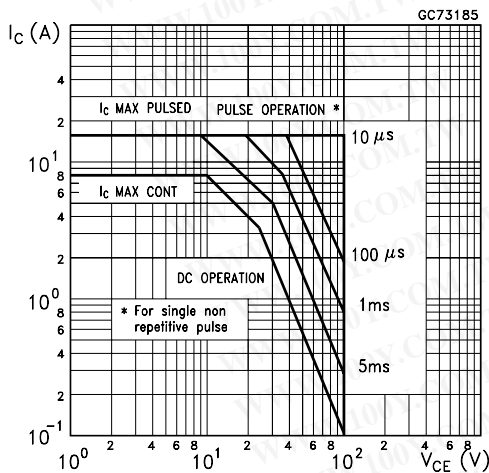

TO-220 MECHANICAL DATA

DIM.	mm			inch		
	MIN.	TYP.	MAX.	MIN.	TYP.	MAX.
A	4.40		4.60	0.173		0.181
C	1.23		1.32	0.048		0.052
D	2.40		2.72	0.094		0.107
E	0.49		0.70	0.019		0.027
F	0.61		0.88	0.024		0.034
F1	1.14		1.70	0.044		0.067
F2	1.14		1.70	0.044		0.067
G	4.95		5.15	0.194		0.202
G1	2.40		2.70	0.094		0.106
H2	10.00		10.40	0.394		0.409
L2		16.40			0.645	
L4	13.00		14.00	0.511		0.551
L5	2.65		2.95	0.104		0.116
L6	15.25		15.75	0.600		0.620
L7	6.20		6.60	0.244		0.260
L9	3.50		3.93	0.137		0.154
M		2.60			0.102	
DIA.	3.75		3.85	0.147		0.151

