



勝特力材料 886-3-5753170
 勝特力电子(上海) 86-21-34970699
 勝特力电子(深圳) 86-755-83298787
 Http://www.100y.com.tw

Z04

Standard

4 A Triacs

Main features

Symbol	Value	Unit
$I_{T(RMS)}$	4	A
V_{DRM}/V_{RRM}	600 to 800	V
$I_{GT}(Q_1)$	3 to 25	mA

Description

The **Z04** series is suitable for general purpose AC switching applications. They can be found in applications such as home appliances (electrovalve, pump, door lock, small lamp control), fan speed controllers,...

Different gate current sensitivities are available, allowing optimized performances when controlled directly from microcontrollers.

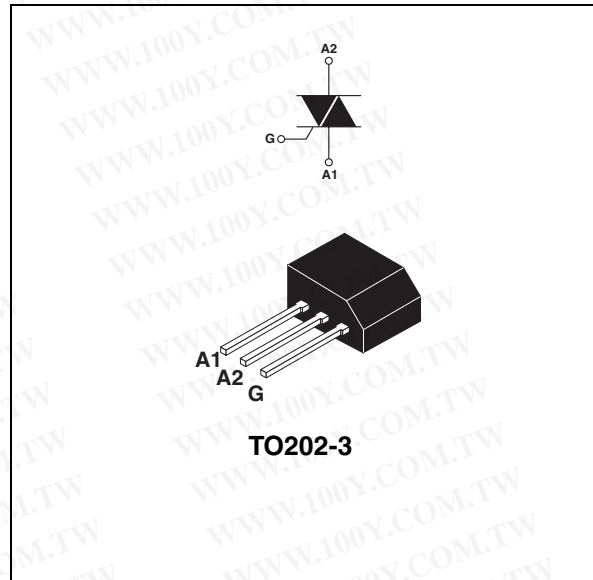

Order codes

Part Number	Marking
Z04xxyF ⁽¹⁾	Z04xxyF ⁽¹⁾

1. xx = sensitivity, y = voltage

Table 1. Absolute maximum ratings

Symbol	Parameter		Value	Unit	
$I_{T(RMS)}$	RMS on-state current (full sine wave)		$T_{amb} = 25^{\circ}C$	4	A
			$T_j = 30^{\circ}C$		
I_{TSM}	Non repetitive surge peak on-state current (full cycle, T_j initial = $25^{\circ}C$)	F = 50 Hz	t = 20 ms	20	A
		F = 60 Hz	t = 16.7 ms	21	
I^2t	I^2t Value for fusing	$t_p = 10$ ms		2.2	A^2s
di/dt	Critical rate of rise of on-state current $I_G = 2 \times I_{GT}$, $t_r \leq 100$ ns	F = 120 Hz	$T_j = 125^{\circ}C$	20	A/ μs
I_{GM}	Peak gate current	$t_p = 20$ μs	$T_j = 125^{\circ}C$	1.2	A
$P_{G(AV)}$	Average gate power dissipation		$T_j = 125^{\circ}C$	0.2	W
T_{stg} T_j	Storage junction temperature range Operating junction temperature range		- 40 to + 150 - 40 to + 125		$^{\circ}C$

1 Characteristics

Table 2. Electrical Characteristics (T_j = 25° C, unless otherwise specified)

Symbol	Test Conditions	Quadrant		Z04				Unit
				02	05	09	10	
I _{GT} ⁽¹⁾	V _D = 12 V R _L = 30 Ω	I - II - III - IV	MAX	3	5	10	25	mA
V _{GT}		ALL	MAX	1.3				V
V _{GD}	V _D = V _{DRM} R _L = 3.3 kΩ T _j = 125° C	ALL	MIN.	0.2				V
I _H ⁽²⁾	I _T = 50 mA		MAX	3	5	10	25	mA
I _L	I _G = 1.2 I _{GT}	I - III - IV	MAX	6	10	15	25	mA
		II		12	15	25	50	
dV/dt ⁽²⁾	V _D = 6 % V _{DRM} gate open T _j = 110° C		MIN.	10	20	100	200	V/μs
(dV/dt) _c ⁽²⁾	(dI/dt) _c = 1.8 A/ms T _j = 110° C		MIN.	0.5	1	2	5	V/μs

1. minimum IGT is guaranteed at 5% of IGT max.
2. for both polarities of A2 referenced to A1.

Table 3. Static Characteristics

Symbol	Test Conditions		Value	Unit		
V _{TM} ⁽¹⁾	I _{TM} = 5.5 A	t _p = 380 μs	T _j = 25° C	MAX.	2.0	V
V _{to} ⁽¹⁾	Threshold voltage		T _j = 125° C	MAX.	0.95	V
R _d ⁽¹⁾	Dynamic resistance		T _j = 125° C	MAX.	180	mΩ
I _{DRM} I _{RPM}	V _{DRM} = V _{RPM}		T _j = 25° C	MAX.	5	μA
			T _j = 125° C		0.5	mA

1. for both polarities of A2 referenced to A1.

Table 4. Thermal resistances

Symbol	Parameter	Value	Unit
R _{th(j-l)}	Junction to lead (AC)	15	° C/W
R _{th(j-a)}	Junction to ambient	100	° C/W

Figure 1. Maximum power dissipation versus RMS on-state current (full cycle)

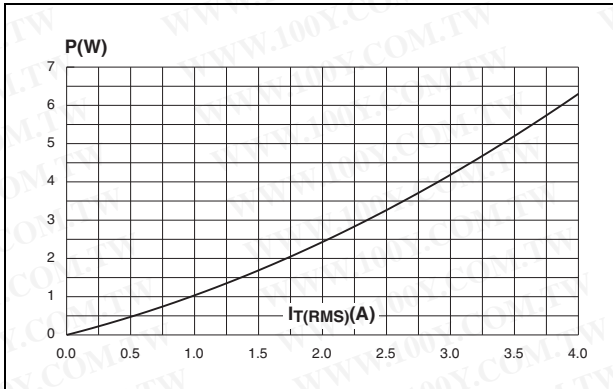

Figure 2. RMS on-state current versus ambient temperature (full cycle)

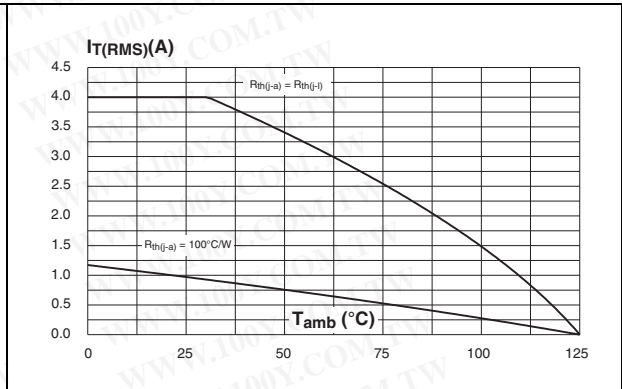

Figure 3. Relative variation of thermal impedance versus pulse duration

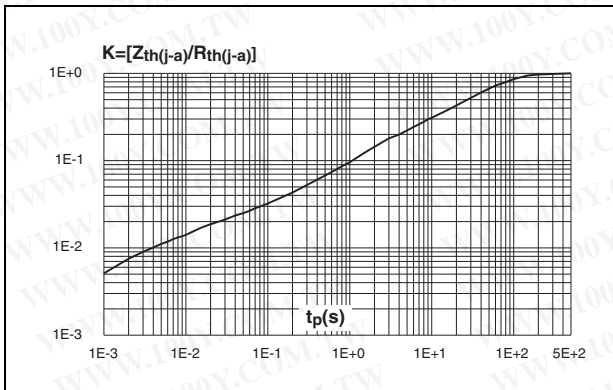

Figure 4. Relative variation of gate trigger current, holding current and latching current versus junction temperature (typical values)

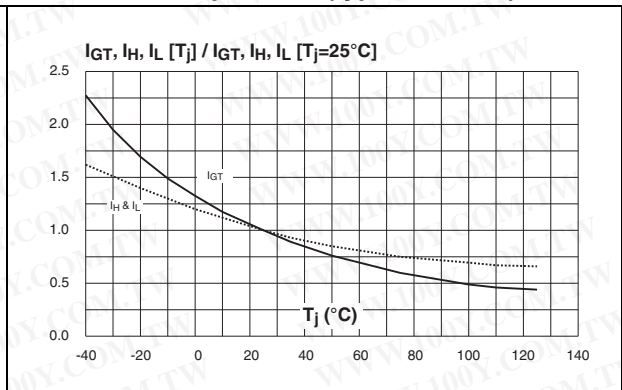

Figure 5. Surge peak on-state current versus number of cycles

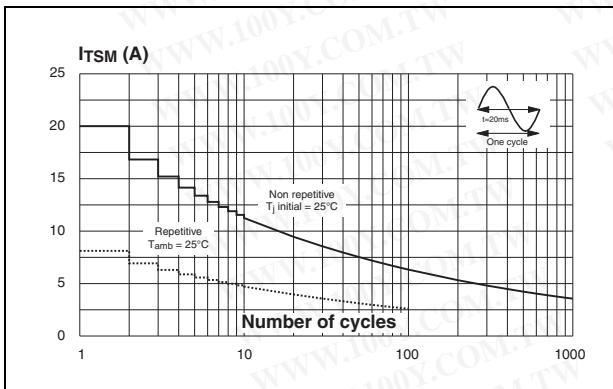

Figure 6. Non-repetitive surge peak on-state current for a sinusoidal pulse with width t_p < 10 ms and corresponding value of I^2t

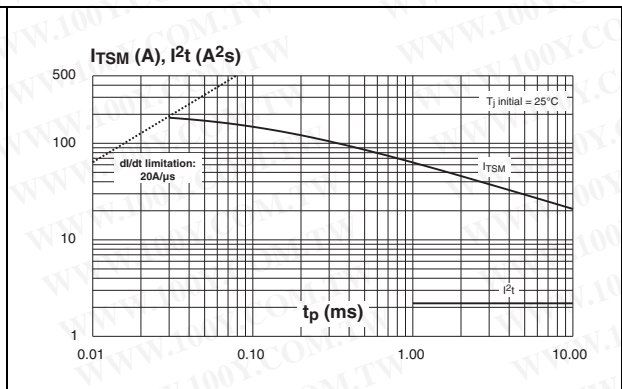

Figure 7. On-state characteristics (maximum values)

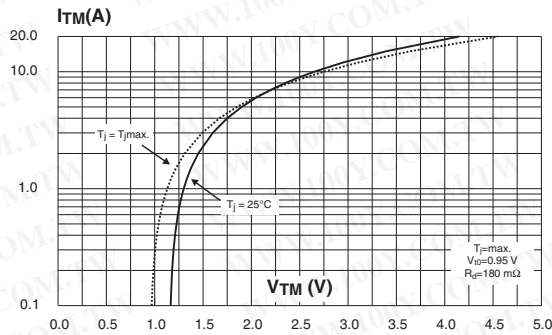

Figure 8. Relative variation of critical rate of decrease of main current versus $(dV/dt)_c$ (typical values)

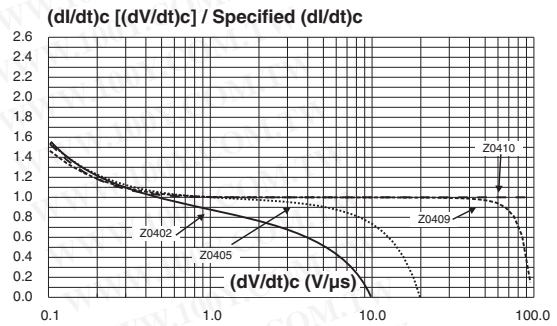
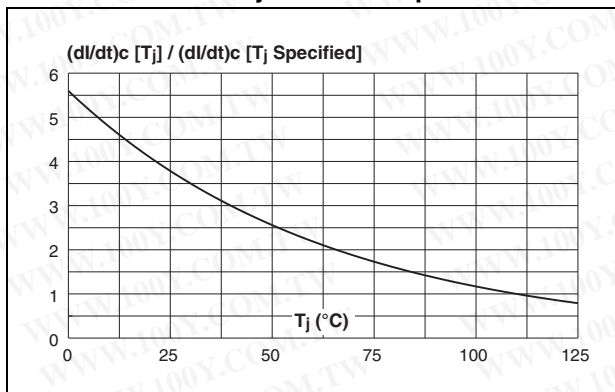

Figure 9. Relative variation of critical rate of decrease of main current versus junction temperature



2 Ordering information scheme

	Z	04	xx	y	F	[BLANK]	0AA2
Triac series							
Current							
04 = 4A							
Sensitivity							
02 = 3mA							
05 = 5mA							
09 = 10mA							
10 = 25mA							
Voltage							
M = 600V							
S = 700V							
N = 800V							
Package							
F = TO202-3							
Packing mode							
0AA2 = Tube							

Table 5. Product selector

Part Number	Voltage			Sensitivity	Type	Package
	600 V	700 V	800 V			
Z0402MF	X			3 mA	Standard	TO202-3
Z0402SF		X		3 mA		
Z0402NF			X	3 mA		
Z0405MF	X			5 mA		
Z0405SF		X		5 mA		
Z0405NF			X	5 mA		
Z0409MF	X			10 mA		
Z0409SF		X		10 mA		
Z0409NF			X	10 mA		
Z0410MF	X			25 mA		
Z0410SF		X		25 mA		
Z0410NF			X	25 mA		

3 Package information

REF.	DIMENSIONS					
	Millimeters			Inches		
	Min.	Typ.	Max.	Min.	Typ.	Max.
A			10.1			0.398
C		7.3			0.287	
D		10.5			0.413	
F			1.5			0.059
H		0.51			0.020	
J		1.5			0.059	
M		4.5			0.177	
N			5.3			0.209
N1		2.54			0.100	
O			1.4			0.055
P			0.7			0.028

In order to meet environmental requirements, ST offers these devices in ECOPACK® packages. These packages have a lead-free second level interconnect. The category of second level interconnect is marked on the package and on the inner box label, in compliance with JEDEC Standard JESD97. The maximum ratings related to soldering conditions are also marked on the inner box label. ECOPACK is an ST trademark. ECOPACK specifications are available at: www.st.com.

4 Ordering information

Ordering type	Marking	Weight	Base qty	Delivery mode
Z04xxyF 0AA2 ⁽¹⁾	Z04xxyF ⁽¹⁾	0.8 g	50	Tube

1. xx = sensitivity, y = voltage

5 Revision history

Date	Revision	Description of Changes
Oct-2001	4	Last update.
13-Feb-2006	5	TO202-3 delivery mode changed from bulk to tube. ECOPACK statement added.
31-Mar-2006	6	Reformatted to current standard. Lead marking changed on page 1
12-05-2006	7	Typographical error for (dV/dt)c corrected in Table 2.

勝特力材料 886-3-5753170
 勝特力电子(上海) 86-21-34970699
 勝特力电子(深圳) 86-755-83298787
[Http://www.100y.com.tw](http://www.100y.com.tw)