

9097250 TOSHIBA (DISCRETE/OPTO)

56C 07830 DT-33-11

SILICON NPN TRIPLE DIFFUSED MESA TYPE

2SD870

COLOR TV HORIZONTAL OUTPUT APPLICATIONS.

FEATURES:

- High Voltage : $V_{CB0}=1500V$
- Low Saturation Voltage
: $V_{CE(sat)}=5V$ (Max.) ($I_C=4A$, $I_B=0.8A$)
- High Speed ; $t_f=1.0\mu s$ (Max.) ($I_{CP}=4A$, $I_{B1}(end)=0.8A$)
- Built-in Damper Type.
- Glass Passivated Collector-Base Junction.

MAXIMUM RATINGS ($T_a=25^\circ C$)

CHARACTERISTIC	SYMBOL	RATING	UNIT
Collector-Base Voltage	V_{CB0}	1500	V
Collector-Emitter Voltage	V_{CEO}	600	V
Emitter-Base Voltage	V_{EBO}	5	V
Collector Current	I_C	5	A
Emitter Current	I_E	-5	A
Collector Power Dissipation ($T_c=25^\circ C$)	P_C	50	W
Junction Temperature	T_j	150	$^\circ C$
Storage Temperature Range	T_{stg}	-65~150	$^\circ C$

EQUIVALENT CIRCUIT

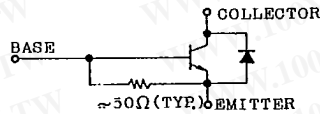
ELECTRICAL CHARACTERISTICS ($T_a=25^\circ C$)

CHARACTERISTIC	SYMBOL	TEST CONDITION	MIN.	TYP.	MAX.	UNIT
Collector Cut-off Current	I_{CBO}	$V_{CB}=500V$, $I_E=0$	-	-	10	μA
Emitter-Base Breakdown Voltage	$V_{(BR)EBO}$	$I_E=200mA$, $I_C=0$	5	-	-	V
DC Current Gain	h_{FE}	$V_{CE}=5V$, $I_C=1.0A$	8	12	-	
Collector-Emitter Saturation Voltage	$V_{CE(sat)}$	$I_C=4A$, $I_B=0.8A$	-	3	5	V
Base-Emitter Saturation Voltage	$V_{BE(sat)}$	$I_C=4A$, $I_B=0.8A$	-	-	1.5	V
Forward Voltage (Damper Diode)	$-V_F$	$I_F=5A$	-	1.6	2.0	V
Transition Frequency	f_T	$V_{CE}=10V$, $I_C=0.1A$	-	3	-	MHz
Collector Output Capacitance	C_{ob}	$V_{CB}=10V$, $I_E=0$, $f=1MHz$	-	165	-	pF
Fall Time (Fig.)	t_f	$I_{CP}=4A$, $I_{B1}(end)=0.8A$	-	0.5	1.0	μs

Unit in mm

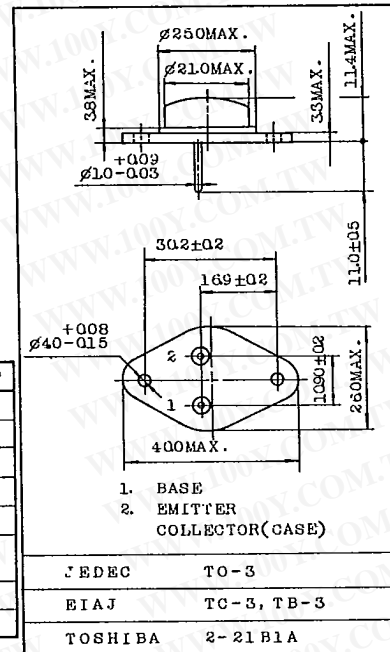

JEDEC TO-3
EIAJ TC-3, TB-3
TOSHIBA 2-21B1A

Mounting kit No. AC42C
Weight : 17g

TOSHIBA CORPORATION

-763-

勝特力材料 886-3-5753170
勝特力电子(上海) 86-21-54151736
勝特力电子(深圳) 86-755-83298787
[Http://www.100y.com.tw](http://www.100y.com.tw)

9097250 TOSHIBA (DISCRETE/OPTO)

56C 07831

DT-33-11

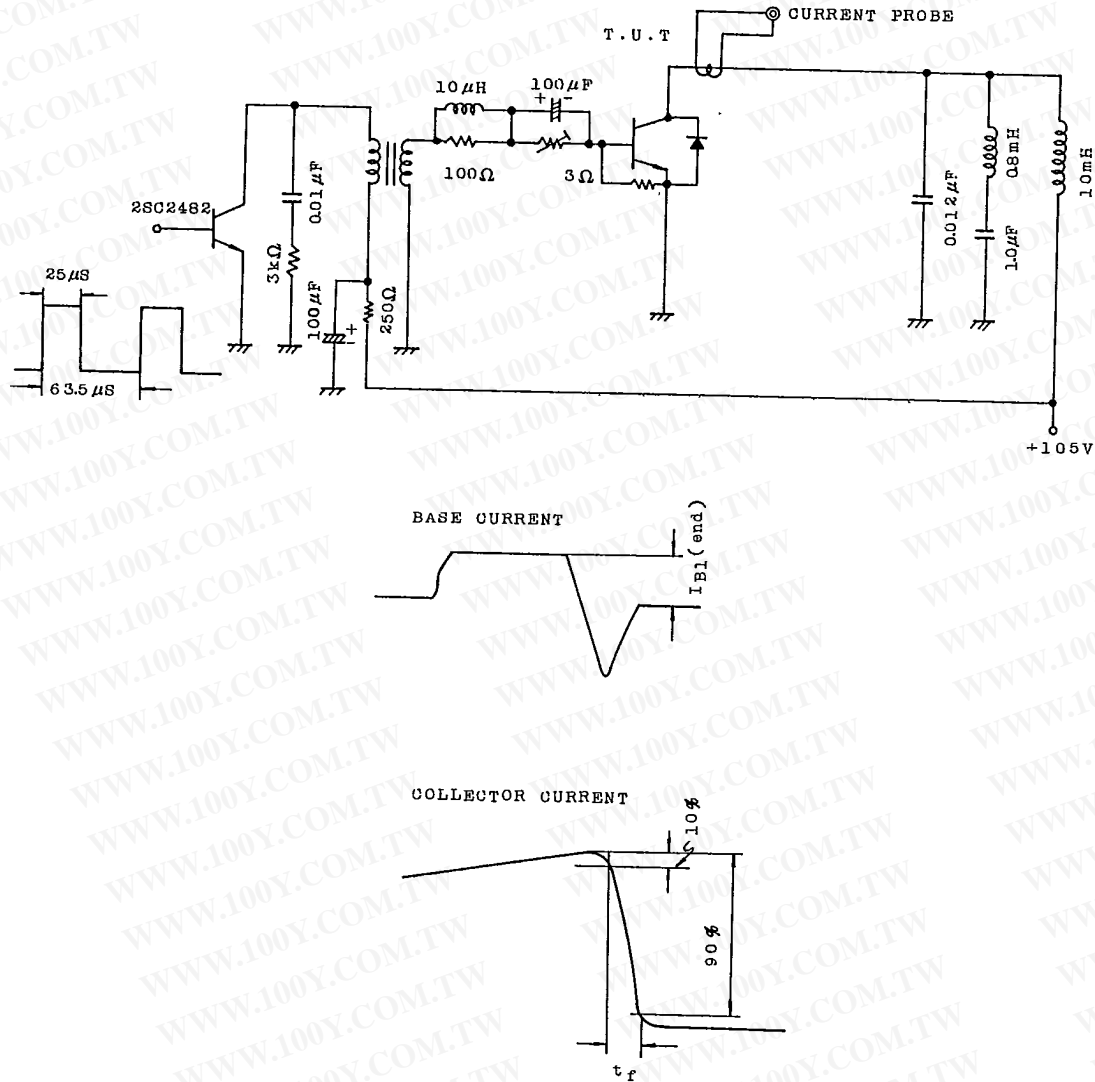
2SD870Fig. t_f TEST CIRCUIT

TOSHIBA CORPORATION

-764-

勝特力材料 886-3-5753170
 勝特力电子(上海) 86-21-54151736
 勝特力电子(深圳) 86-755-83298787
[Http://www.100y.com.tw](http://www.100y.com.tw)

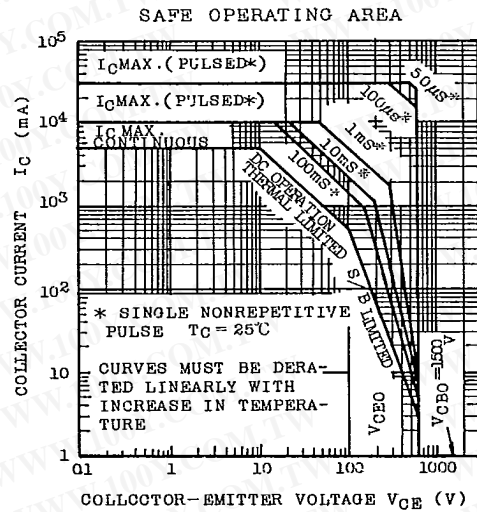
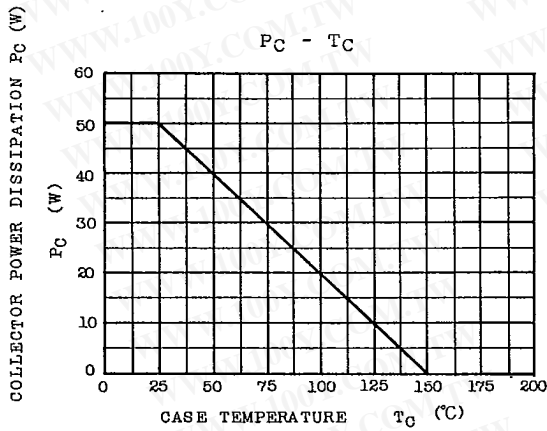
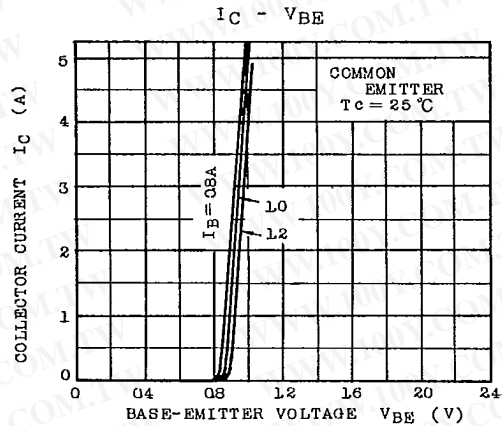
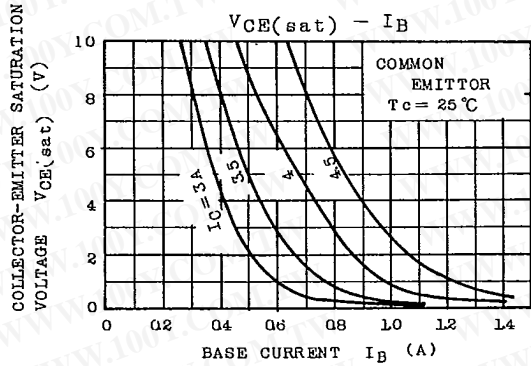
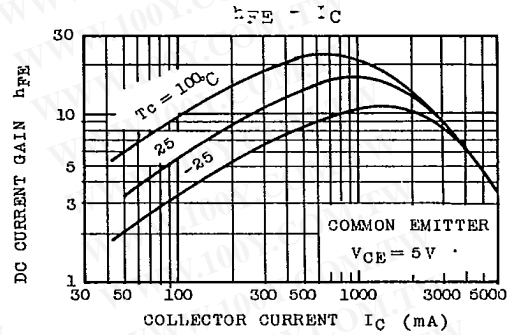
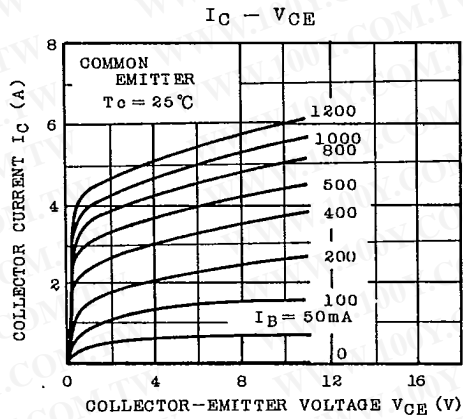

TOSHIBA CORPORATION

勝特力材料 886-3-5753170
 勝特力电子(上海) 86-21-54151736
 勝特力电子(深圳) 86-755-83298787
[Http://www.100y.com.tw](http://www.100y.com.tw)