

TOSHIBA INSULATED GATE BIPOLAR TRANSISTOR SILICON N CHANNEL MOS TYPE

# GT30J322

THE 4TH GENERATION

Unit in mm

CURRENT RESONANCE INVERTER SWITCHING APPLICATIONS

- FRD Included Between Emitter and Collector
- Enhancement-Mode
- High Speed :  $t_f = 0.25 \mu s$  (Typ.) ( $I_C = 50A$ )
- Low Saturation Voltage :  $V_{CE(sat)} = 2.1V$  (Typ.) ( $I_C = 50A$ )

MAXIMUM RATINGS ( $T_a = 25^\circ C$ )

CHARACTERISTIC	SYMBOL	RATING	UNIT
Collector-Emitter Voltage	$V_{CES}$	600	V
Gate-Emitter Voltage	$V_{GES}$	$\pm 20$	V
Collector Current	DC	$I_C$	30
	1ms	$I_{CP}$	100
Emitter-Collector Forward Current	DC	$I_F$	30
	1ms	$I_{FP}$	60
Collector Power Dissipation ( $T_c = 25^\circ C$ )	$P_C$	75	W
Junction Temperature	$T_j$	150	$^\circ C$
Storage Temperature Range	$T_{stg}$	$-55 \sim 150$	$^\circ C$

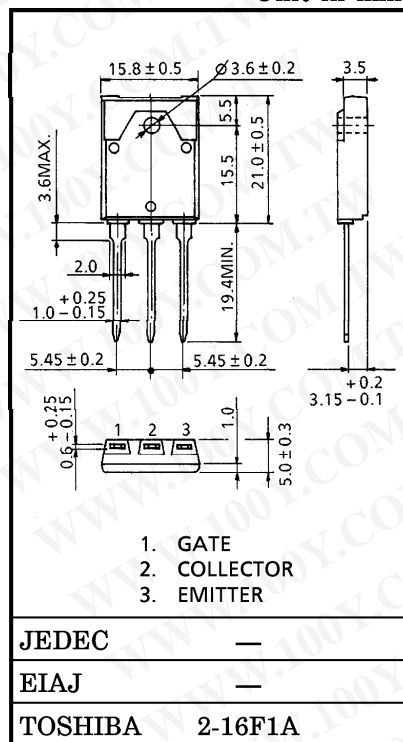

Weight : 5.8g

EQUIVALENT CIRCUIT

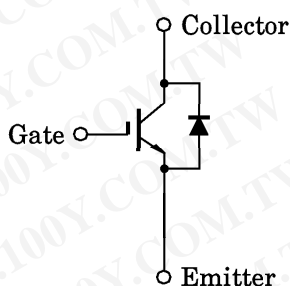

勝特力材料 886-3-5753170  
 勝特力电子(上海) 86-21-34970699  
 勝特力电子(深圳) 86-755-83298787  
[Http://www.100y.com.tw](http://www.100y.com.tw)

961001EAA1

● TOSHIBA is continually working to improve the quality and the reliability of its products. Nevertheless, semiconductor devices in general can malfunction or fail due to their inherent electrical sensitivity and vulnerability to physical stress. It is the responsibility of the buyer, when utilizing TOSHIBA products, to observe standards of safety, and to avoid situations in which a malfunction or failure of a TOSHIBA product could cause loss of human life, bodily injury or damage to property. In developing your designs, please ensure that TOSHIBA products are used within specified operating ranges as set forth in the most recent products specifications. Also, please keep in mind the precautions and conditions set forth in the TOSHIBA Semiconductor Reliability Handbook.

● The information contained herein is presented only as a guide for the applications of our products. No responsibility is assumed by TOSHIBA CORPORATION for any infringements of intellectual property or other rights of the third parties which may result from its use. No license is granted by implication or otherwise under any intellectual property or other rights of TOSHIBA CORPORATION or others.

● The information contained herein is subject to change without notice.

ELECTRICAL CHARACTERISTICS (Ta = 25°C)

CHARACTERISTIC		SYMBOL	TEST CONDITION	MIN.	TYP	MAX.	UNIT
Gate Leakage Current		$I_{GES}$	$V_{GE} = \pm 20V, V_{CE} = 0$	—	—	$\pm 500$	nA
Collector Cut-off Current		$I_{CES}$	$V_{CE} = 600V, V_{GE} = 0$	—	—	1.0	mA
Gate-Emitter Cut-off Voltage		$V_{GE(OFF)}$	$I_C = 50mA, V_{CE} = 5V$	3.0	—	6.0	V
Collector-Emitter Saturation Voltage		$V_{CE(sat)}$	$I_C = 50A, V_{GE} = 15V$	—	2.1	2.8	V
Input Capacitance		$C_{ies}$	$V_{CE} = 10V, V_{GE} = 0, f = 1MHz$	—	2500	—	pF
Switching Time	Rise Time	$t_r$		—	0.20	—	$\mu s$
	Turn-on Time	$t_{on}$		—	0.30	—	
	Fall Time	$t_f$		—	0.25	0.40	
	Turn-off Time	$t_{off}$		—	0.40	—	
Forward Voltage		$V_F$	$I_F = 30A, V_{GE} = 0$	—	—	2.0	V
Reverse Recovery Time		$t_{rr}$	$I_F = 30A, V_{GE} = 0$ $di/dt = -100A/\mu s$	—	—	0.2	$\mu s$
Thermal Resistance		$R_{th(j-c)}$	IGBT	—	—	1.67	$^{\circ}C/W$
Thermal Resistance		$R_{th(j-e)}$	Diode	—	—	2.27	$^{\circ}C/W$

勝特力材料 886-3-5753170  
 勝特力电子(上海) 86-21-34970699  
 勝特力电子(深圳) 86-755-83298787  
[Http://www.100y.com.tw](http://www.100y.com.tw)

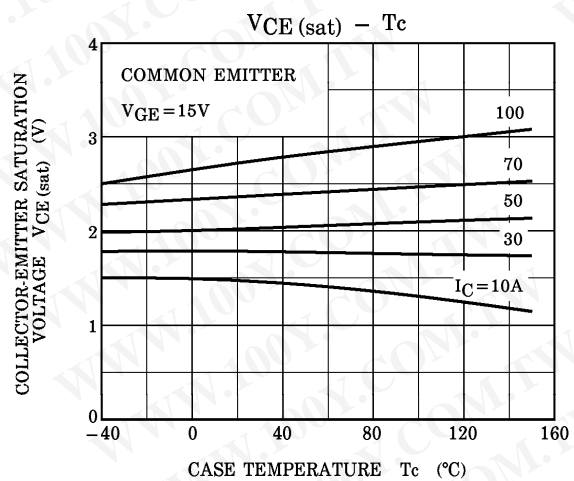
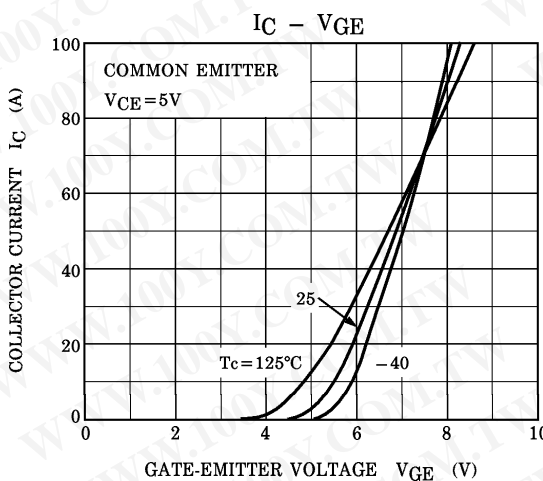
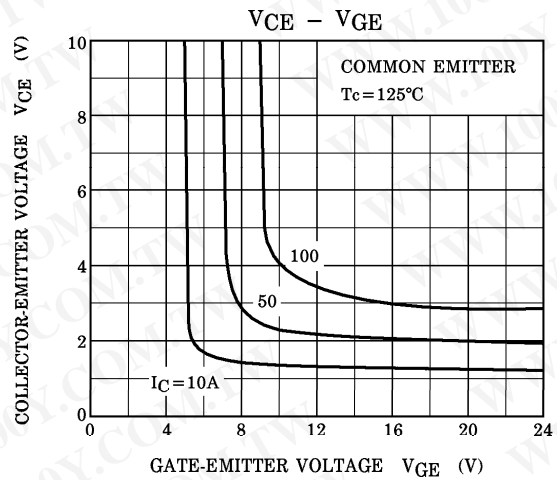
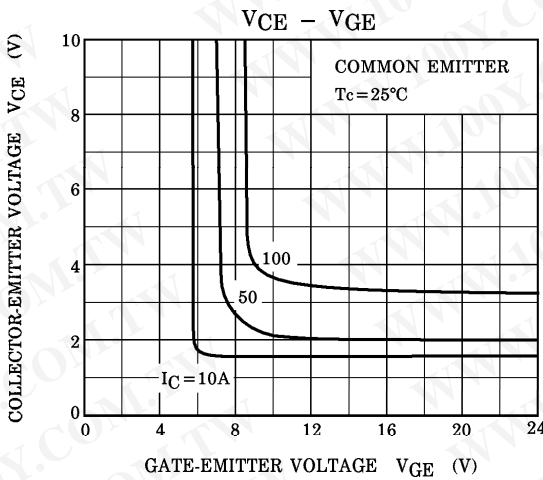
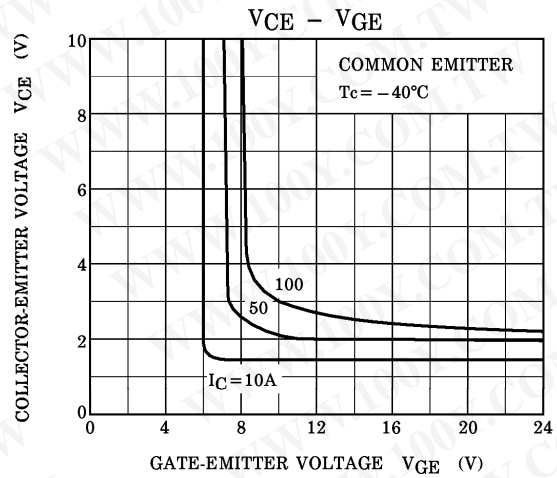
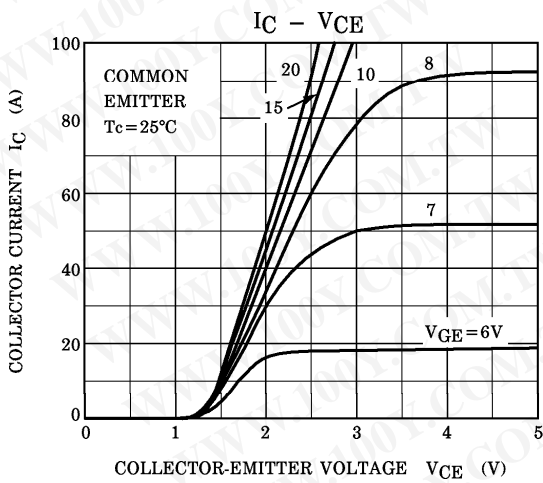

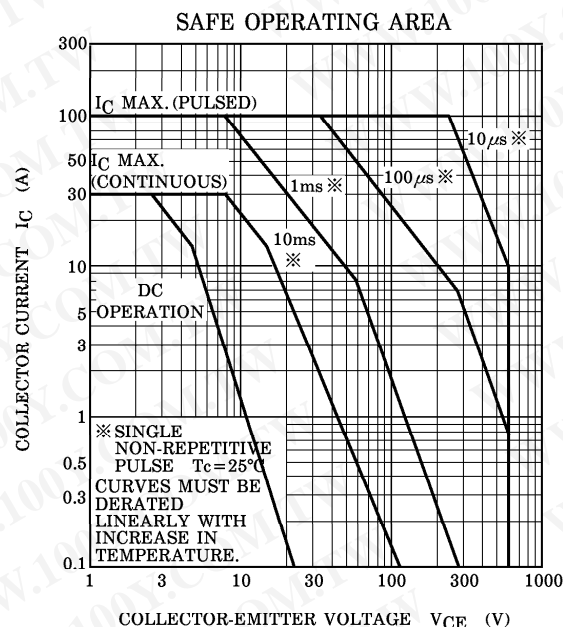
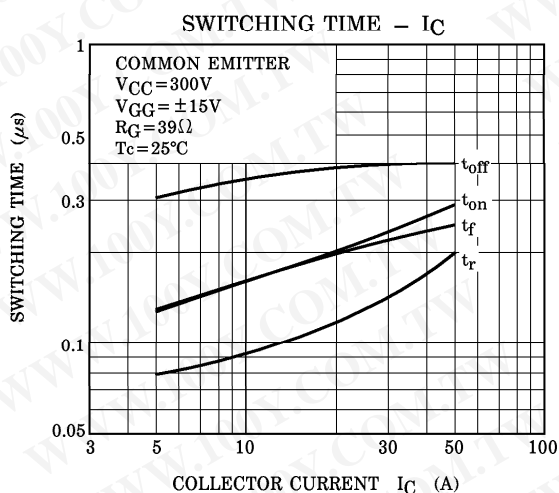
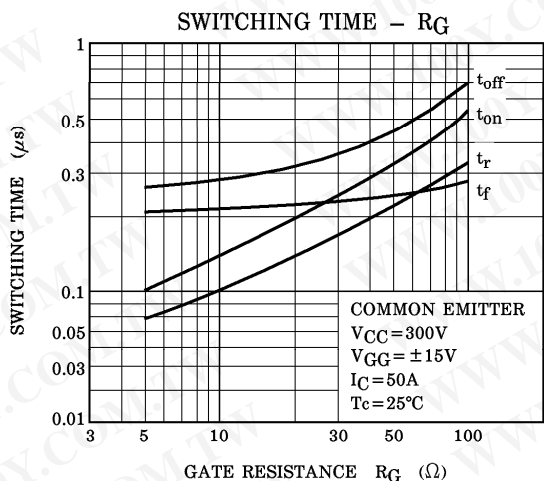
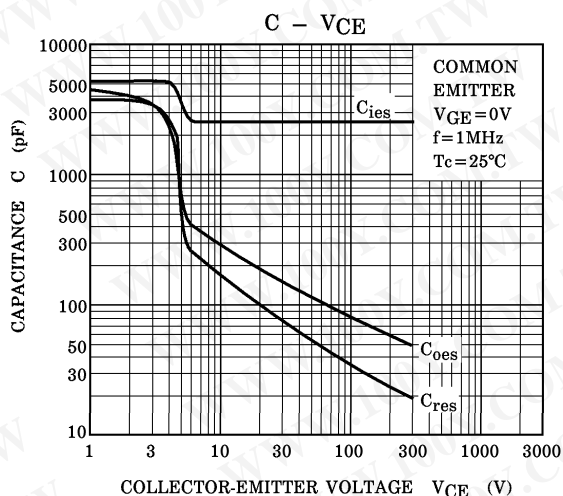
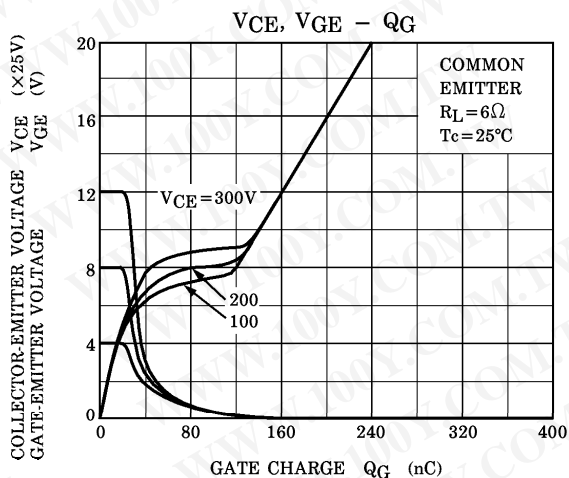

勝特力材料 886-3-5753170  
 勝特力电子(上海) 86-21-34970699  
 勝特力电子(深圳) 86-755-83298787  
[Http://www.100y.com.tw](http://www.100y.com.tw)

