

**Features**

- ✧ For surface mounted application
- ✧ Glass passivated junction chip
- ✧ Built-in strain relief, ideal for automated placement
- ✧ Plastic material used carries Underwriters Laboratory Classification 94V-0
- ✧ Fast switching for high efficiency
- ✧ High temperature soldering: 260°C / 10 seconds at terminals
- ✧ Green compound with suffix "G" on packing code & prefix "G" on datecode

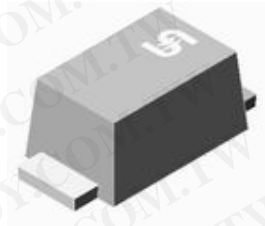

**Mechanical Data**

- ✧ Case: Molded plastic
- ✧ Terminals: Solder plated
- ✧ Polarity: Indicated by cathode band
- ✧ Packing: 8mm / 12mm tape per EIA STD RS-481
- ✧ Weight: 0.0196 grams

**Ordering Information (example)**

Part No.	Package	Packing	Packing code	Packing code (Green)
RS1AL	Sub-SMA	3K / 7" REEL	RV	RVG

**Maximum Ratings and Electrical Characteristics**

Rating at 25 °C ambient temperature unless otherwise specified.

Parameter	Symbol	RS1 AL	RS1 BL	RS1 DL	RS1 GL	RS1 JL	RS1 KL	RS1 ML	Unit
Maximum Repetitive Peak Reverse Voltage	$V_{RRM}$	50	100	200	400	600	800	1000	V
Maximum RMS Voltage	$V_{RMS}$	35	70	140	280	420	560	700	V
Maximum DC Blocking Voltage	$V_{DC}$	50	100	200	400	600	800	1000	V
Maximum Average Forward Rectified Current	$I_{F(AV)}$	0.8							A
Peak Forward Surge Current, 8.3 ms Single Half Sine-wave Superimposed on Rated Load (JEDEC method)	$I_{FSM}$	30							A
Maximum Instantaneous Forward Voltage (Note 1) @ 0.8A	$V_F$	1.3							V
Maximum Reverse Current @ Rated VR $T_A=25\text{ }^\circ\text{C}$ $T_A=125\text{ }^\circ\text{C}$	$I_R$	5 50							$\mu\text{A}$
Maximum Reverse Recovery Time (Note 2)	$T_{rr}$	150			250	500		nS	
Typical Junction Capacitance (Note 3)	$C_j$	10							pF
Typical Thermal Resistance	$R_{\theta JA}$ $R_{\theta JL}$	105 32							$^\circ\text{C/W}$
Operating Temperature Range	$T_J$	- 55 to + 150							$^\circ\text{C}$
Storage Temperature Range	$T_{STG}$	- 55 to + 150							$^\circ\text{C}$

Note 1: Pulse Test with PW=300 usec, 1% Duty Cycle

Note 2: Reverse Recovery Test Conditions:  $I_F=0.5\text{A}$ ,  $I_R=1.0\text{A}$ ,  $I_{RR}=0.25\text{A}$

Note 3: Measured at 1 MHz and Applied Reverse Voltage of 4.0V D.C.

**RATINGS AND CHARACTERISTIC CURVES (RS1AL THRU RS1ML)**

**FIG.1 FORWARD CURRENT DERATING CURVE**

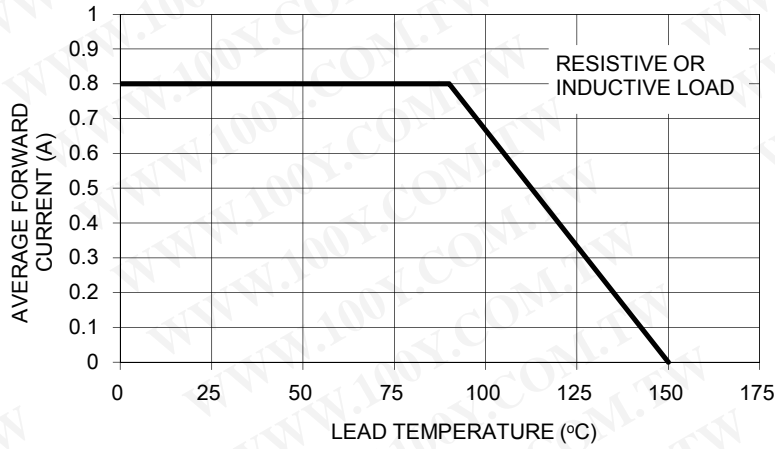

**FIG. 2 TYPICAL REVERSE CHARACTERISTICS**

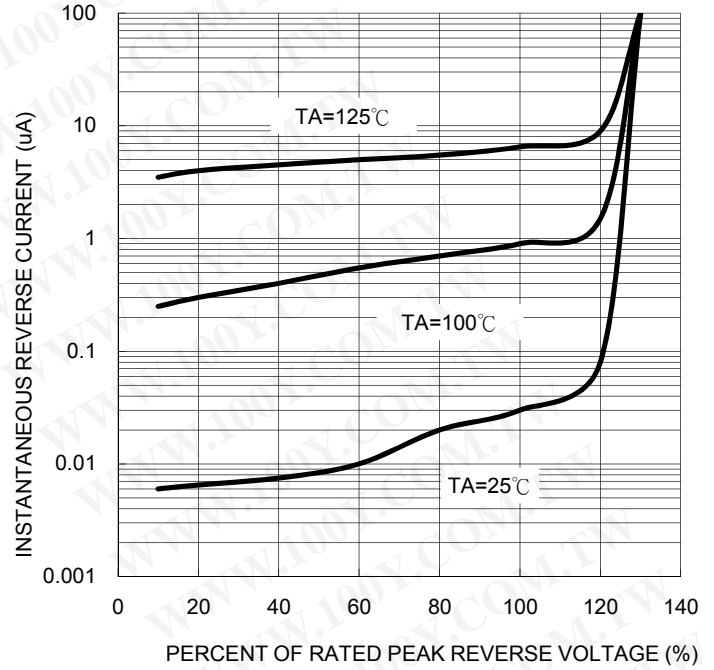

**FIG. 3 MAXIMUM NON-REPETITIVE FORWARD SURGE CURRENT**

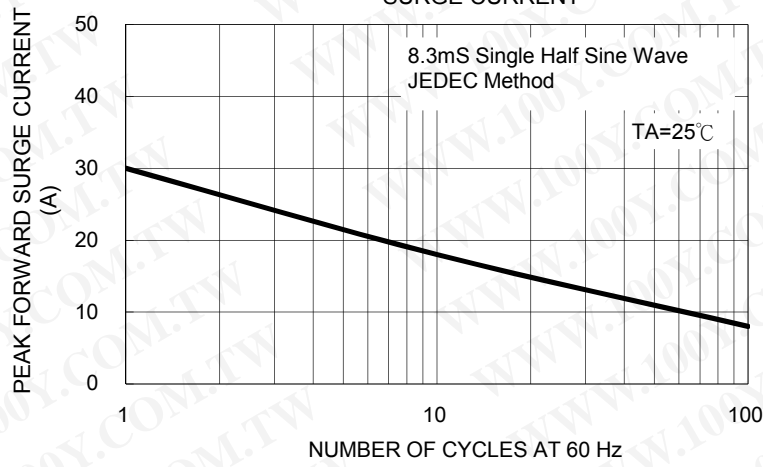

**FIG. 5 TYPICAL FORWARD CHARACTERISTICS**

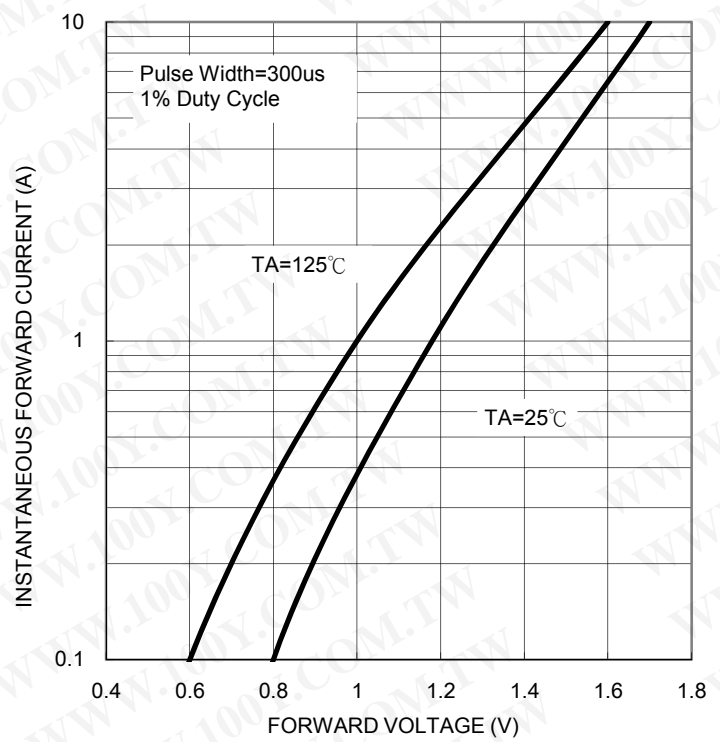

**FIG. 4 TYPICAL JUNCTION CAPACITANCE**

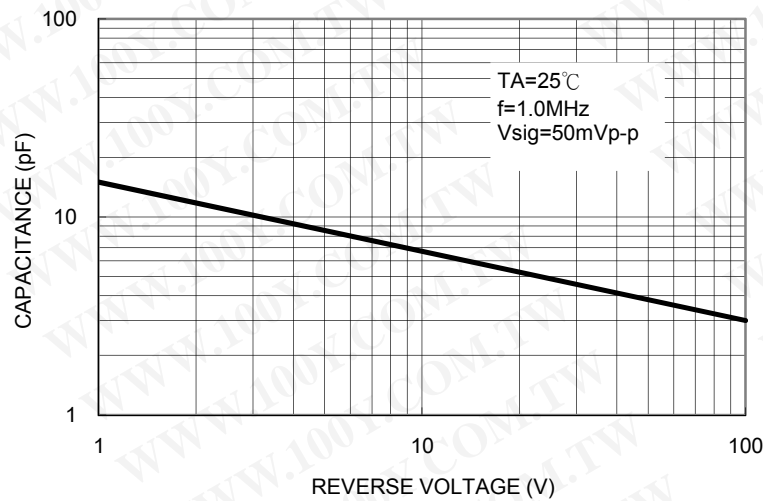

**FIG.6- REVERSE RECOVERY TIME CHARACTERISTIC AND TEST CIRCUIT DIAGRAM**

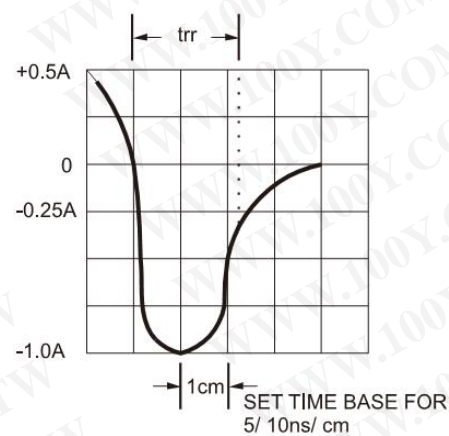
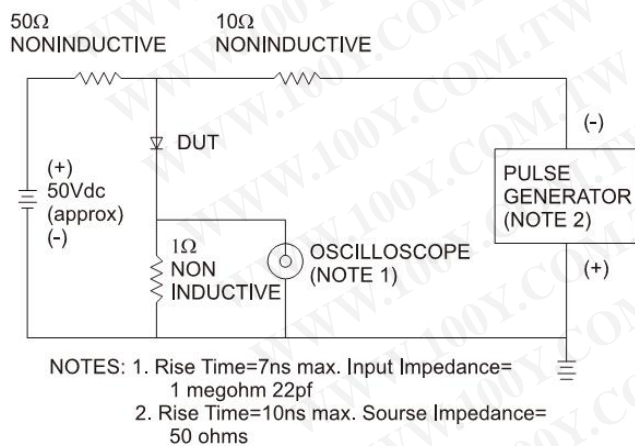

**Ordering information**

Part No.	Package	Packing	Tape Size	Packing code	Packing code (Green)
RS1xL (Note)	Sub-SMA	1.8K / 7" REEL	8mm	RU	RUG
	Sub-SMA	3K / 7" REEL	8mm	RV	RVG
	Sub-SMA	7.5K / 13" REEL	8mm	RT	RTG
	Sub-SMA	7.5K / 13" Plastic REEL	8mm	MT	MTG
	Sub-SMA	10K / 13" REEL	8mm	RQ	RQG
	Sub-SMA	10K / 13" Plastic REEL	8mm	MQ	MQG
	Sub-SMA	1.8K / 7" REEL	12mm	R3	R3G
	Sub-SMA	3K / 7" REEL	12mm	RF	RFG
	Sub-SMA	7.5K / 13" REEL	12mm	R2	R2G
	Sub-SMA	7.5K / 13" Plastic REEL	12mm	M2	M2G
	Sub-SMA	10K / 13" REEL	12mm	RH	RHG
	Sub-SMA	10K / 13" Plastic REEL	12mm	MH	MHG

Note: "x" is Device Code from "A" thru "M".

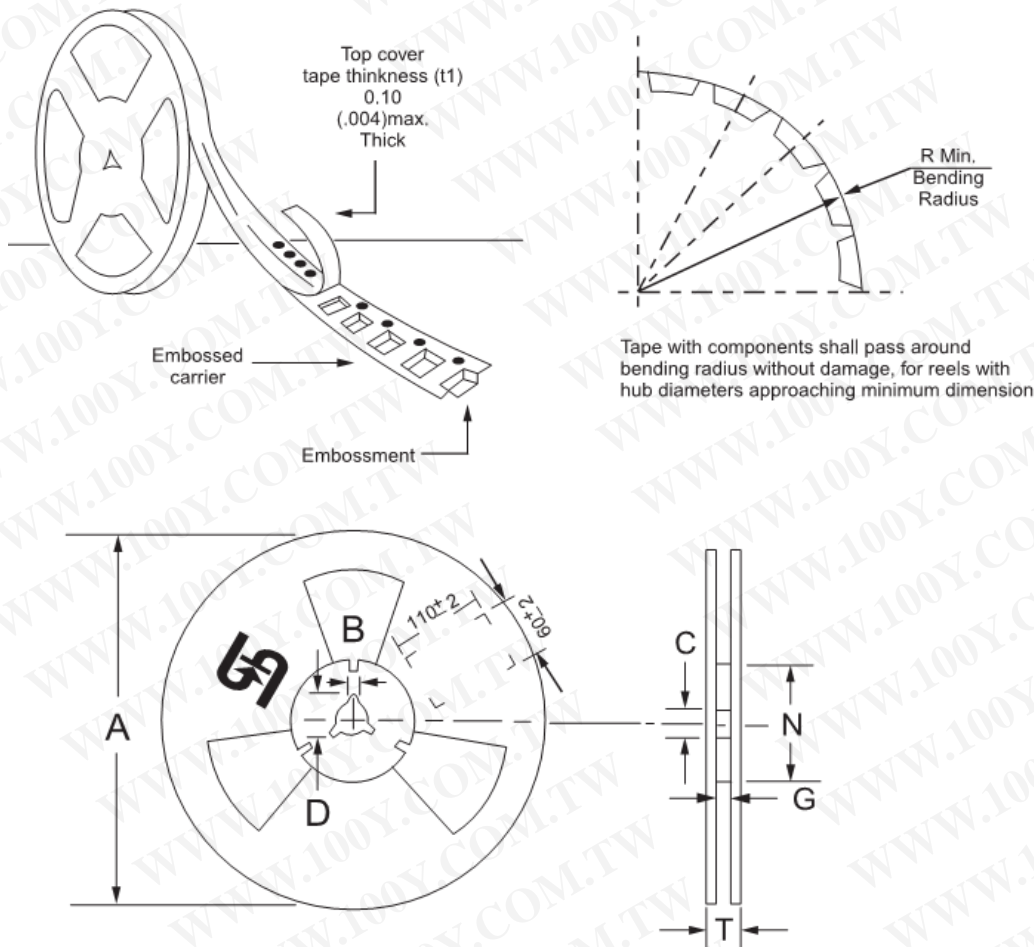
**Tape & Reel specification**

Reel Size	Tape Size	A	B	C	D	N	G	T
7"	8mm	±2.0	±0.4	+0.5;-0.2	min	±1.0	+0.8;-0	max
	12mm	178	1.9	13	21	62	8.2	10.6
13"	8mm	max	±0.5	±0.5	min	±0.5	+2.0;-0	max
	12mm	330	2	13	20.2	75	8.5	14.5
							12.4	18.4

Unit (mm)

**Suggested PAD Layout**

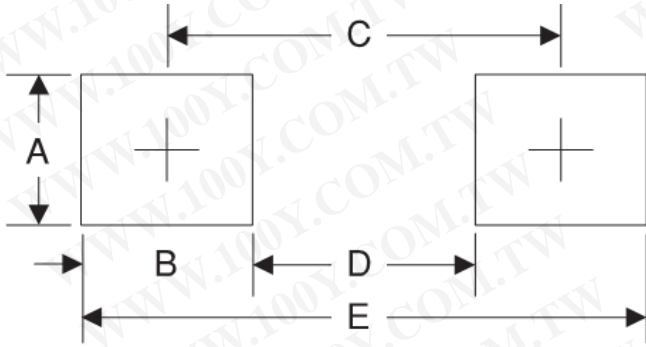

Symbol	Unit(mm)
A	1.4
B	1.2
C	3.1
D	1.9
E	4.3

**Package Outline Dimensions**

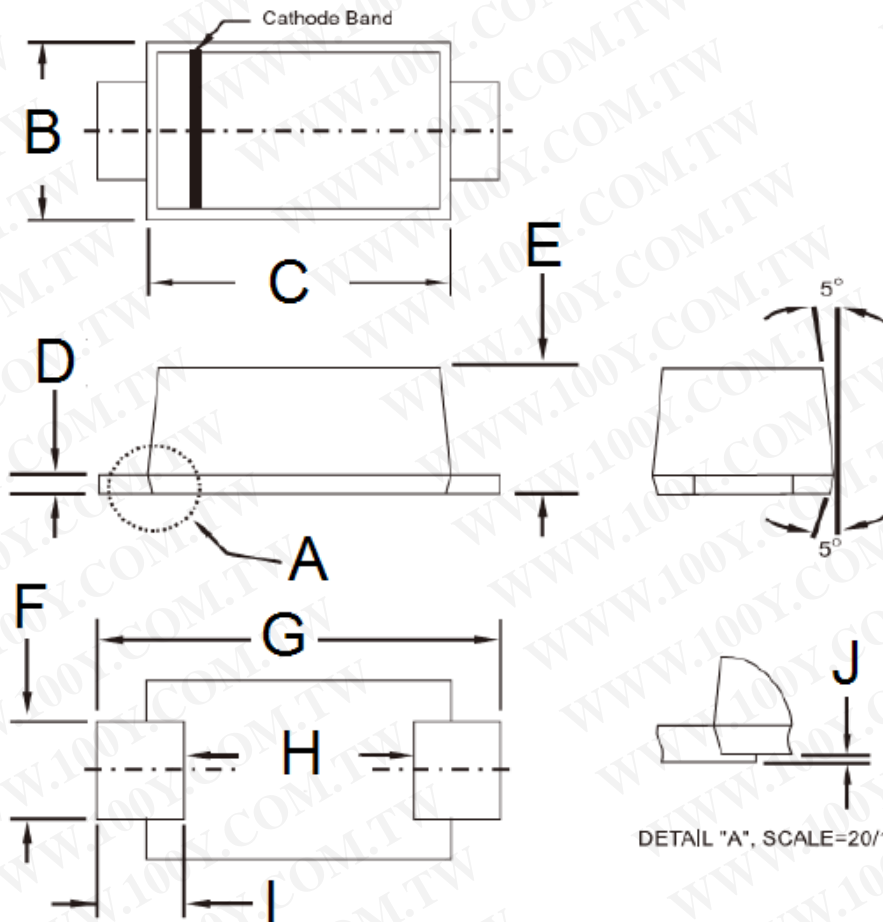

DIM.	Unit(mm)		Unit(inch)	
	Min	Max	Min	Max
B	1.70	1.90	0.067	0.075
C	2.70	2.90	0.106	0.114
D	0.16	0.30	0.006	0.012
E	1.23	1.43	0.048	0.056
F	0.80	1.20	0.031	0.047
G	3.40	3.80	0.134	0.150
H	2.45	2.60	0.096	0.102
I	0.35	0.85	0.014	0.033
J	0.00	0.10	0.000	0.004

DETAIL "A", SCALE=20/1

**Marking Diagram**

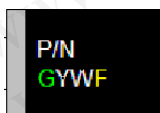

- P/N = Specific Device Code
- G = Green Compound
- YW = Date Code
- F = Factory Code