

## KSE13004/13005

### High Voltage Switch Mode Application

- High Speed Switching
- Suitable for Switching Regulator and Motor Control

勝特力材料 886-3-5753170  
勝特力电子(上海) 86-21-34970699  
勝特力电子(深圳) 86-755-83298787  
[Http://www.100y.com.tw](http://www.100y.com.tw)

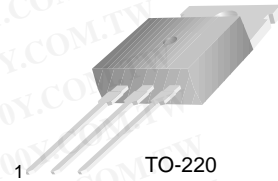

1.Base 2.Collector 3.Emitter

### NPN Silicon Transistor

#### Absolute Maximum Ratings $T_C=25^\circ\text{C}$ unless otherwise noted

Symbol	Parameter	Value	Units
$V_{CBO}$	Collector-Base Voltage	: KSE13004	600
		: KSE13005	700
$V_{CEO}$	Collector-Emitter Voltage	: KSE13004	300
		: KSE13005	400
$V_{EBO}$	Emitter-Base Voltage	9	V
$I_C$	Collector Current (DC)	4	A
$I_{CP}$	Collector Current (Pulse)	8	A
$I_B$	Base Current	2	A
$P_C$	Collector Dissipation ( $T_C=25^\circ\text{C}$ )	75	W
$T_J$	Junction Temperature	150	$^\circ\text{C}$
$T_{STG}$	Storage Temperature	- 65 ~ 150	$^\circ\text{C}$

#### Electrical Characteristics $T_C=25^\circ\text{C}$ unless otherwise noted

Symbol	Parameter	Test Condition	Min.	Typ.	Max.	Units
$BV_{CEO(sus)}$	Collector-Emitter Sustaining Voltage	$I_C = 10\text{mA}, I_B = 0$	: KSE13004	300		V
			: KSE13005	400		V
$I_{EBO}$	Emitter Cut-off Current	$V_{EB} = 9\text{V}, I_C = 0$			1	mA
$h_{FE}$	*DC Current Gain	$V_{CE} = 5\text{V}, I_C = 1\text{A}$ $V_{CE} = 5\text{V}, I_C = 2\text{A}$	10 8		60 40	
$V_{CE(sat)}$	*Collector-Emitter Saturation Voltage	$I_C = 1\text{A}, I_B = 0.2\text{A}$ $I_C = 2\text{A}, I_B = 0.5\text{A}$ $I_C = 4\text{A}, I_B = 1\text{A}$			0.5 0.6 1	V V V
$V_{BE(sat)}$	*Base-Emitter Saturation Voltage	$I_C = 1\text{A}, I_B = 0.2\text{A}$ $I_C = 2\text{A}, I_B = 0.5\text{A}$			1.2 1.6	V V
$C_{ob}$	Output Capacitance	$V_{CB} = 10\text{V}, f = 0.1\text{MHz}$		65		pF
$f_T$	Current Gain Bandwidth Product	$V_{CE} = 10\text{V}, I_C = 0.5\text{A}$	4			MHz
$t_{ON}$	Turn On Time	$V_{CC} = 125\text{V}, I_C = 2\text{A}$ $I_{B1} = - I_{B2} = 0.4\text{A}$ $R_L = 62.5\Omega$			0.8	$\mu\text{s}$
$t_{STG}$	Storage Time				4	$\mu\text{s}$
$t_F$	Fall Time				0.9	$\mu\text{s}$

\* Pulse test:  $PW \leq 300\mu\text{s}$ , Duty cycles  $\leq 2\%$  Pulse

# Typical Characteristics

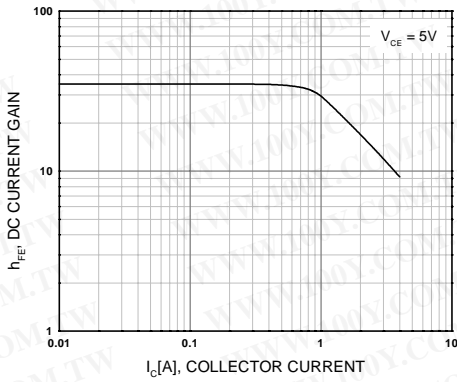

Figure 1. DC current Gain

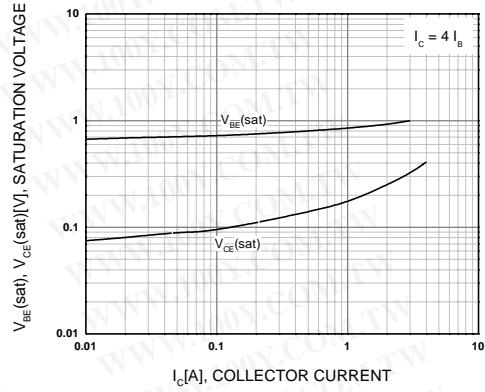

Figure 2. Base-Emitter Saturation Voltage  
Collector-Emitter Saturation Voltage

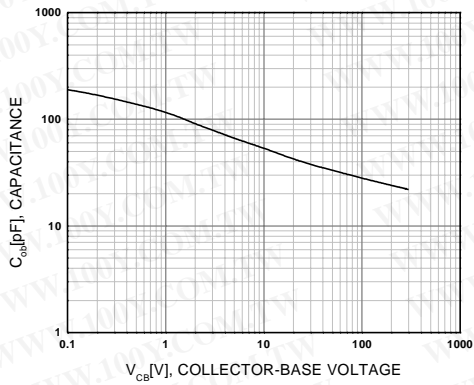

Figure 3. Collector Output Capacitance

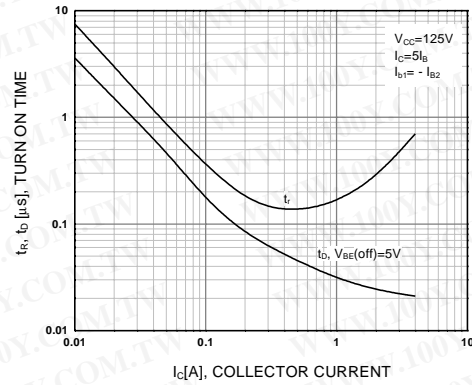

Figure 4. Turn On Time

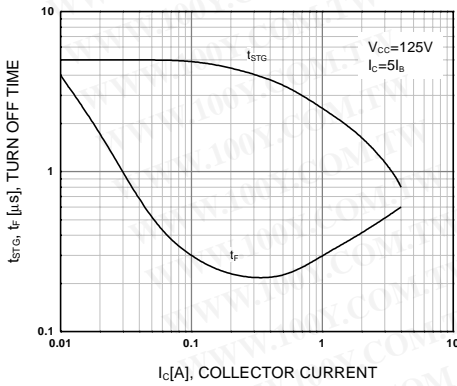

Figure 5. Turn Off Time

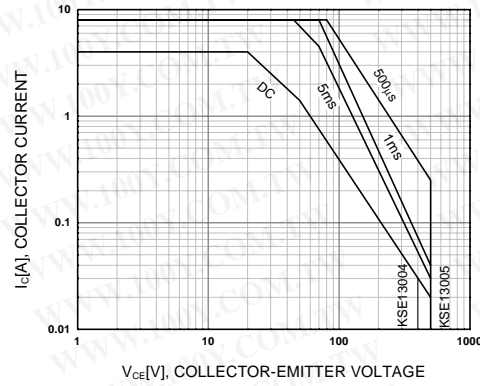

Figure 6. Safe Operating Area

### Typical Characteristics (Continued)

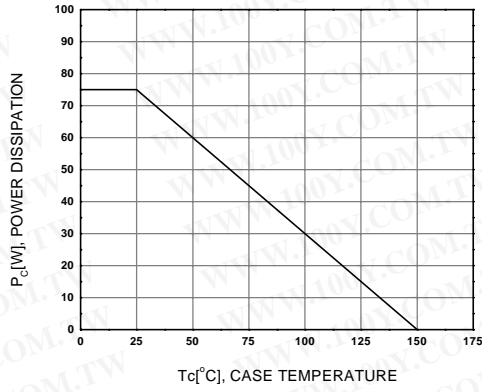
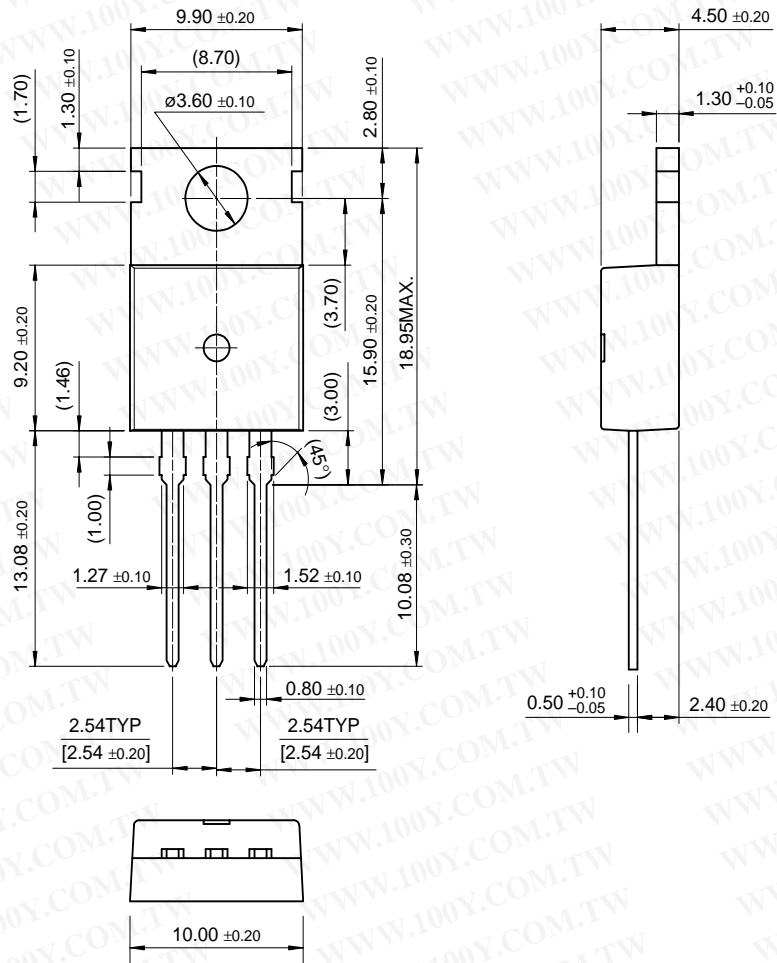

Figure 7. Power Derating

Package Dimensions

TO-220



勝特力材料 886-3-5753170  
 勝特力电子(上海) 86-21-34970699  
 勝特力电子(深圳) 86-755-83298787  
[Http://www.100y.com.tw](http://www.100y.com.tw)

Dimensions in Millimeters