



**Features**

- Dual Channel VGA
- Frequency Range 400MHz to 2700MHz
- Full Internal Matching and No External Bias Inductors
- Two 6-Bit Digital Step Attenuators
- 12-Bit SPI Serial Control Programming
- High Channel Isolation = 50dBc
- Max Gain = 13dB at 900MHz
- Gain Control Range = 31.5dB (0.5dB Step Size)
- High OIP3/P1dB = +39/19dBm at 900MHz
- Single + 5V Supply
- Small 32-Pin, 7.0mm x 7.0mm, MCM
- Power-up Programming

**Applications**

- Cellular, 3G Infrastructure
- WiBro, WiMAX, LTE
- Microwave Radio
- High Linearity Power Control

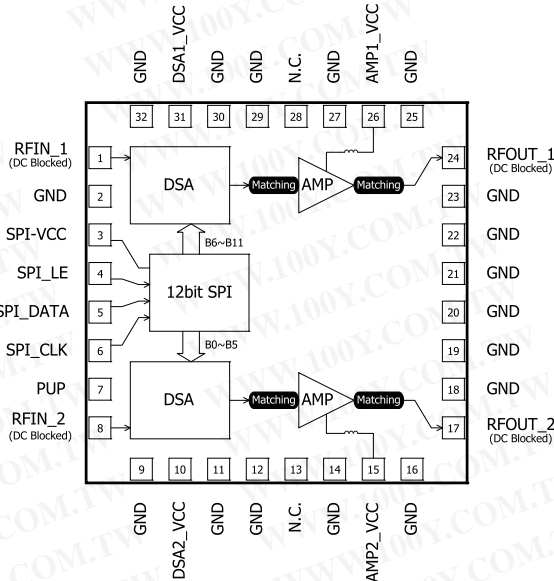

Functional Block Diagram

**Product Description**

RFMD's RFDA0047 is a dual channel digital controlled variable gain amplifier featuring high linearity over the entire gain control range with noise figure less than 6.5dB in its maximum gain state. The gains of two 6-bit digital step attenuators are programmed with a serial mode control interface (SPI). The RFDA0047 is packaged in a small 7.0mm x 7.0mm leadless laminate MCM, which contains plated through thermal vias for ultra-low thermal resistance. This module is easy to use with no external matching components required.

**Ordering Information**

RFDA0047TR13	13" Reel with 2500 pieces
RFDA0047TR7	7" Reel with 750 pieces
RFDA0047SR	7" Reel with 100 pieces
RFDA0047SQ	Sample Bag with 25 pieces
RFDA0047PCK-410	400MHz to 2700MHz PCBA with 5-piece sample bag

**Optimum Technology Matching® Applied**

- |   |                                      |  |                                    |
|---|--------------------------------------|--|------------------------------------|
| <input type="checkbox"/> GaAs HBT             | <input type="checkbox"/> SiGe BiCMOS | <input checked="" type="checkbox"/> GaAs pHEMT | <input type="checkbox"/> GaN HEMT  |
| <input type="checkbox"/> GaAs MESFET          | <input type="checkbox"/> Si BiCMOS   | <input checked="" type="checkbox"/> Si CMOS    | <input type="checkbox"/> BiFET HBT |
| <input checked="" type="checkbox"/> InGaP HBT | <input type="checkbox"/> SiGe HBT    | <input type="checkbox"/> Si BJT                | <input type="checkbox"/> SOI       |

RF MICRO DEVICES®, RFMD®, Optimum Technology Matching®, Enabling Wireless Connectivity™, PowerStar®, POLARIS™ TOTAL RADIO™ and UltimateBlue™ are trademarks of RFMD, LLC. BLUETOOTH is a trademark owned by Bluetooth SIG, Inc., U.S.A. and licensed for use by RFMD. All other trade names, trademarks and registered trademarks are the property of their respective owners. ©2012, RF Micro Devices, Inc.

## Absolute Maximum Ratings

Parameter	Rating	Unit
Supply Voltage	+5.5	V <sub>DC</sub>
DS Supply Current	205	mA
Power Dissipation	1100	mW
Maximum Input RF Power	24	dBm
Operating Temperature (T <sub>CASE</sub> )	-40 to +85	°C
Storage Temperature	-40 to +150	°C
Junction Temperature	165	°C
ESD Rating (HBM)	500 (Class 1B)	V
Moisture Sensitivity Level	MSL 3	

MTTF = 1.0E6 hours at 165 °C junction temperature



**Caution!** ESD sensitive device.

Exceeding any one or a combination of the Absolute Maximum Rating conditions may cause permanent damage to the device. Extended application of Absolute Maximum Rating conditions to the device may reduce device reliability. Specified typical performance or functional operation of the device under Absolute Maximum Rating conditions is not implied.

The information in this publication is believed to be accurate and reliable. However, no responsibility is assumed by RF Micro Devices, Inc. ("RFMD") for its use, nor for any infringement of patents, or other rights of third parties, resulting from its use. No license is granted by implication or otherwise under any patent or patent rights of RFMD. RFMD reserves the right to change component circuitry, recommended application circuitry and specifications at any time without prior notice.



RFMD Green: RoHS compliant per EU Directive 2002/95/EC, halogen free per IEC 61249-2-21, < 1000ppm each of antimony trioxide in polymeric materials and red phosphorus as a flame retardant, and <2% antimony in solder.

Parameter	Specification			Unit	Condition
	Min.	Typ.	Max.		
<b>Overall</b>					Temp=25 °C, V <sub>CC</sub> = V <sub>DD</sub> = 5V, standard application circuit
Frequency	400		2700	MHz	
Max Gain		13		dB	Attenuation = 0dB
Gain Control Range		31.5		dB	
Step Accuracy	+/- (0.15+5% attenuation setting)			dB	Major state error up to 2700MHz
P1dB		19		dBm	Attenuation = 0dB at 900MHz
Output IP3		39		dBm	P <sub>OUT</sub> = 0dBm/tone, 1MHz spacing at 900MHz
Control Interface		12		bit	SPI interface
Settling Time		250		ns	tON, tOFF (10%/90% RF)
Noise Figure		7		dB	Attenuation = 0dB
Channel-to-Channel Isolation		50		dB	Input at RFIN1 (or RFIN2), the isolation between two outputs
Impedance		50		Ω	
Input Return Loss		-18		dB	900MHz
Output Return Loss		-18		dB	900MHz
Total Supply Voltage	4.75	5.0	5.25	V	
Supply Current		170		mA	From V <sub>CC-SPI</sub> , V <sub>CC-AMP1</sub> and V <sub>CC-AMP2</sub>
Thermal Resistance		40		°C/W	Junction to backside of device

Parameter	Unit	680MHz	900MHz	1700MHz	2300MHz	2550MHz	2700MHz
Max Small Signal Gain	dB	13.5	13.5	13.3	13	13	13
Output P1dB	dBm	19	19	19	18	18	17.5
Output IP3*	dBm	40	39.5	35	32.5	31.5	31
Noise Figure	dB	6.5	6.5	7	7.5	7.5	7.5

\* Note: OIP3 is tested at P<sub>OUT</sub> = 0dBm/Tone and 1MHz spacing

**Typical Broadband Performance  $V_{CC} = 5.0V, I_{CC} = 170mA$**

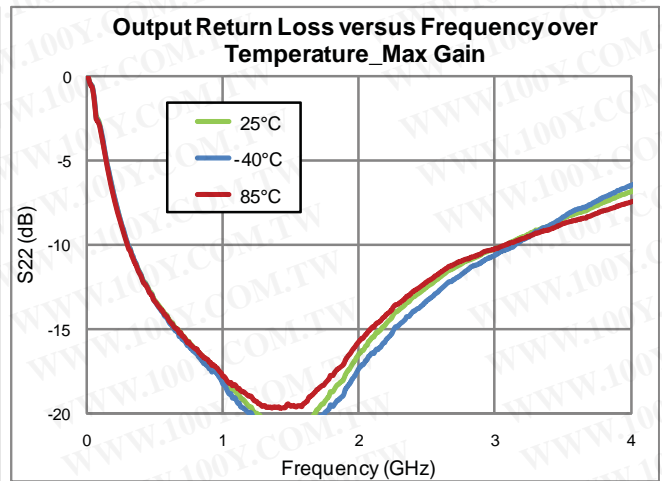
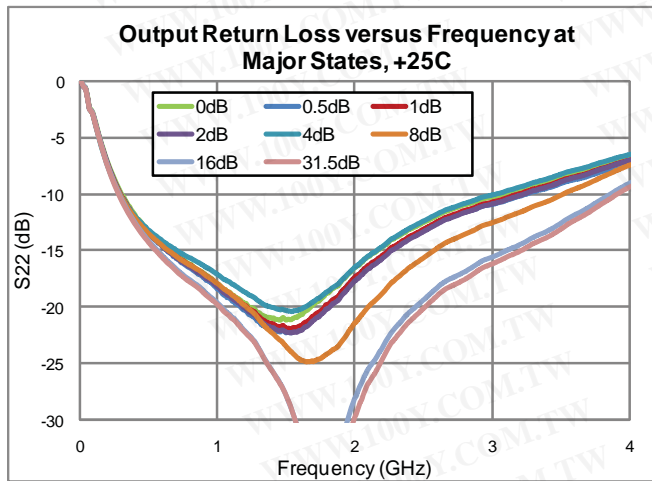
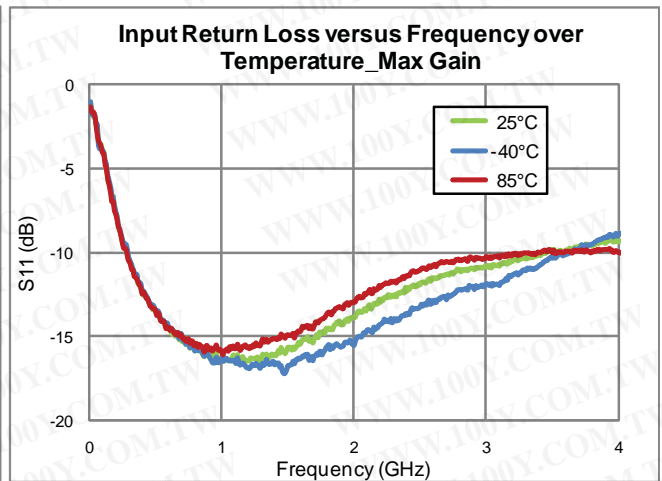
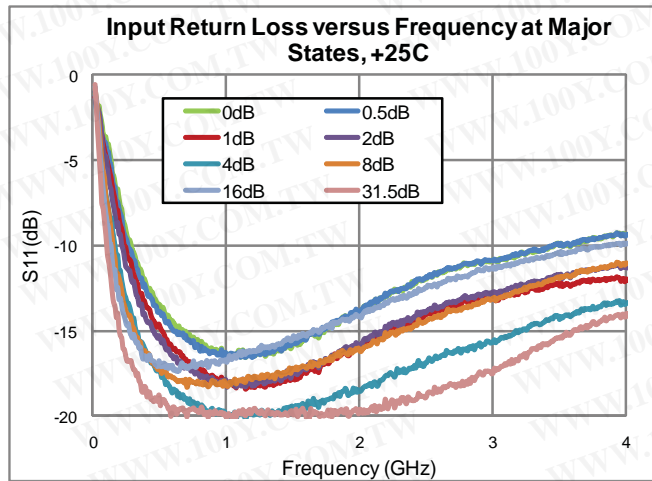
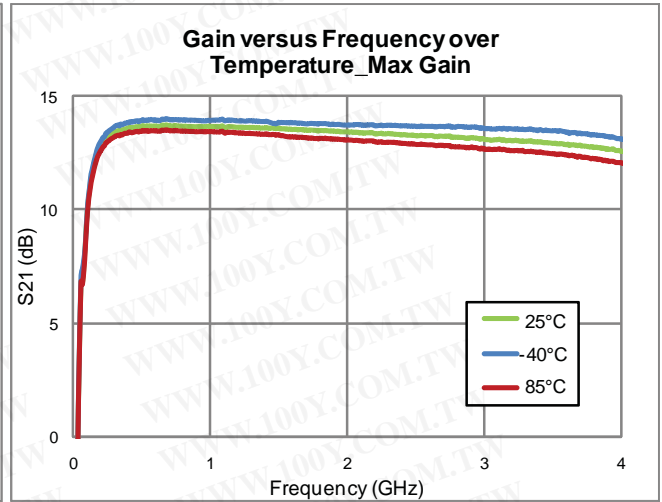
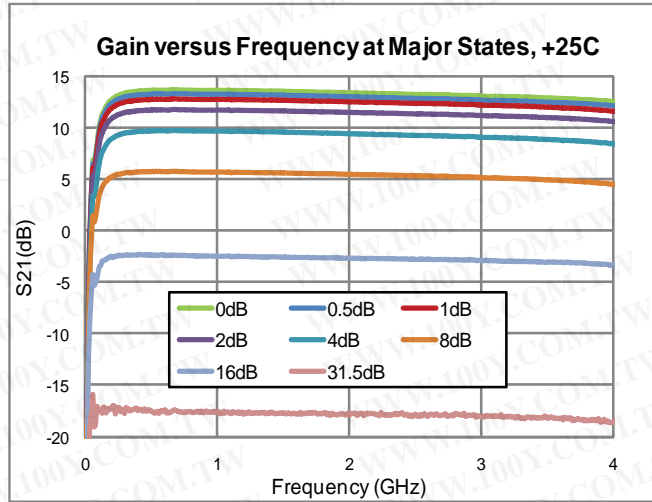

## Typical Broadband Performance $V_{CC} = 5.0V, I_{CC} = 170mA$

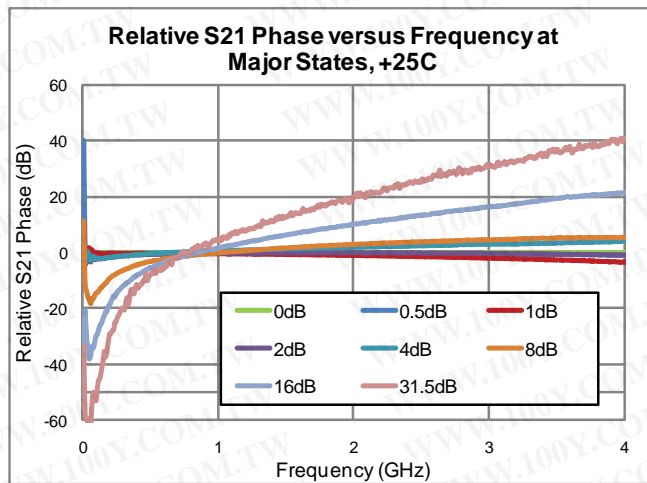
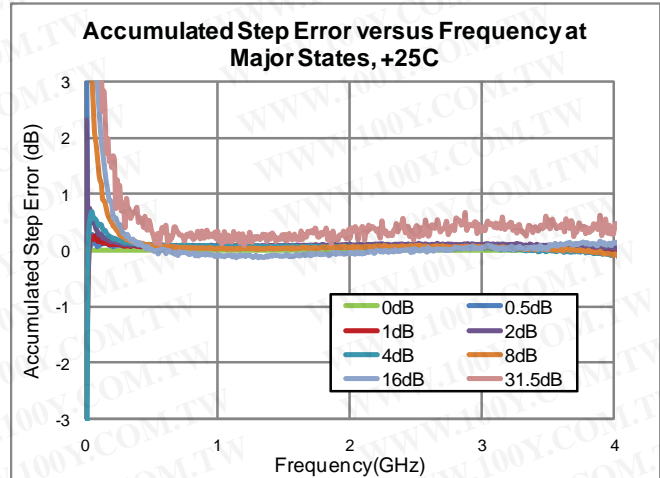
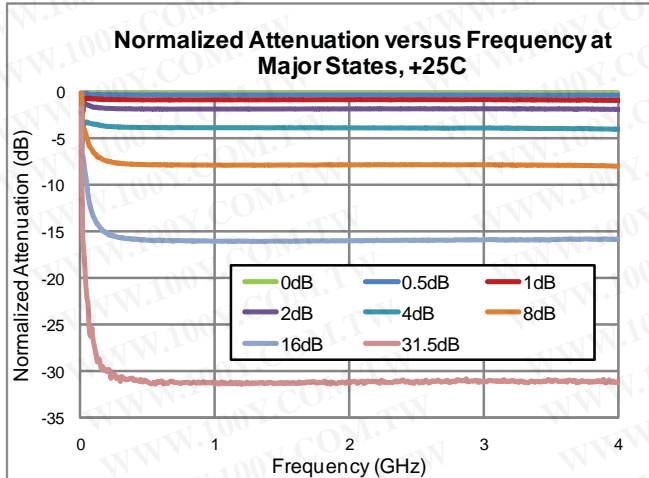
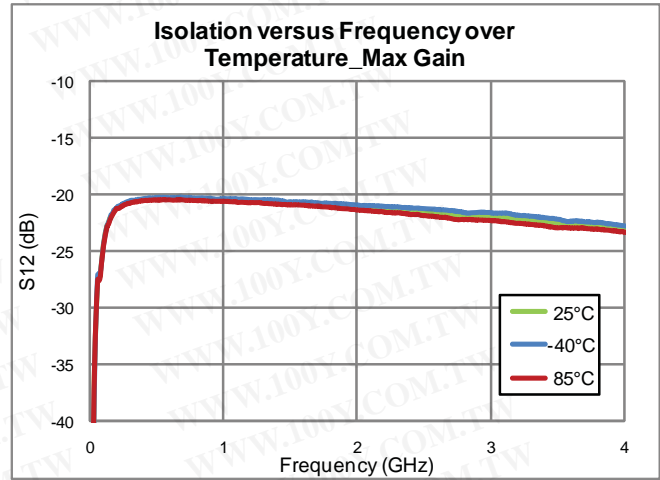
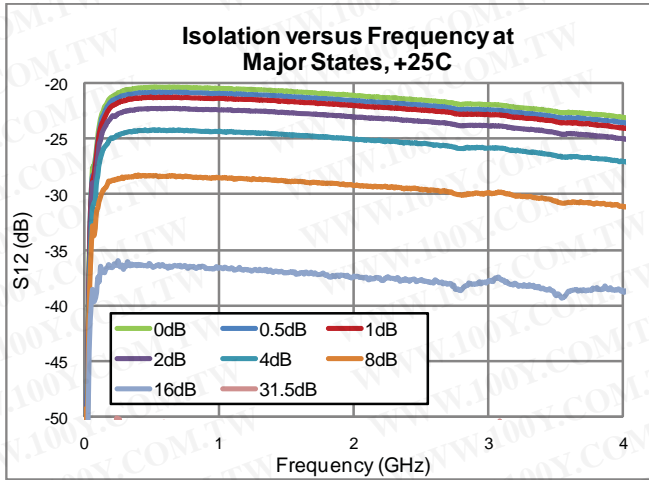



**Typical Broadband Performance  $V_{CC} = 5.0V, I_{CC} = 170mA$**

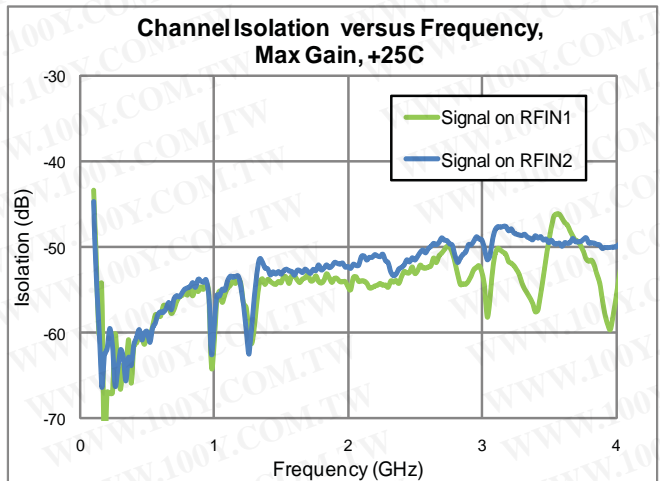
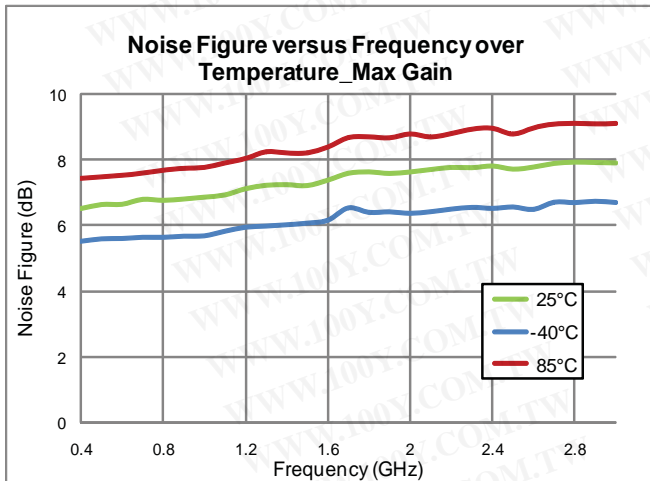
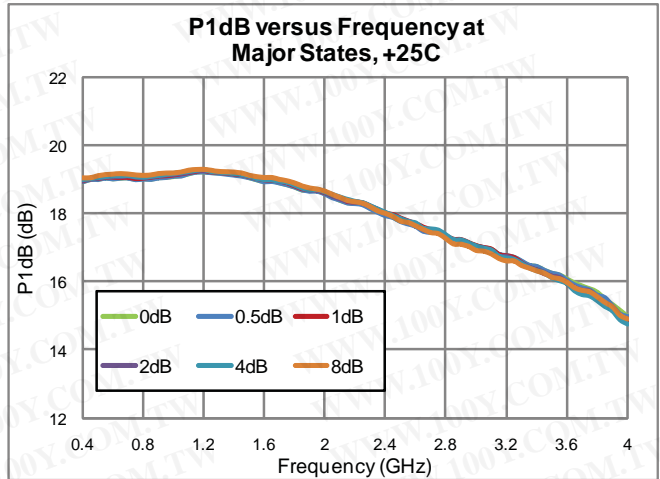
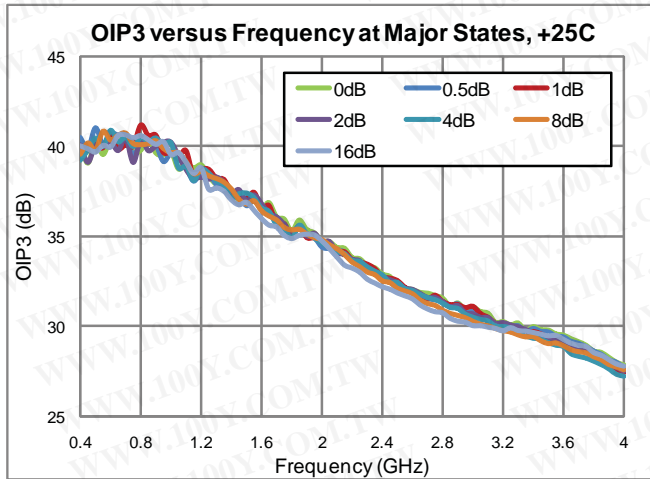
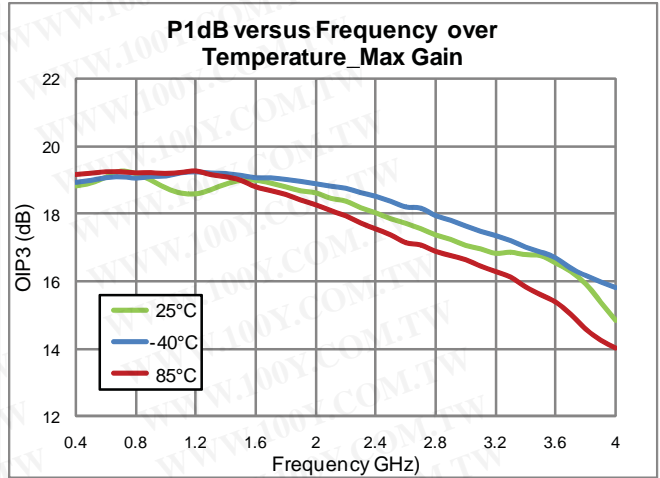
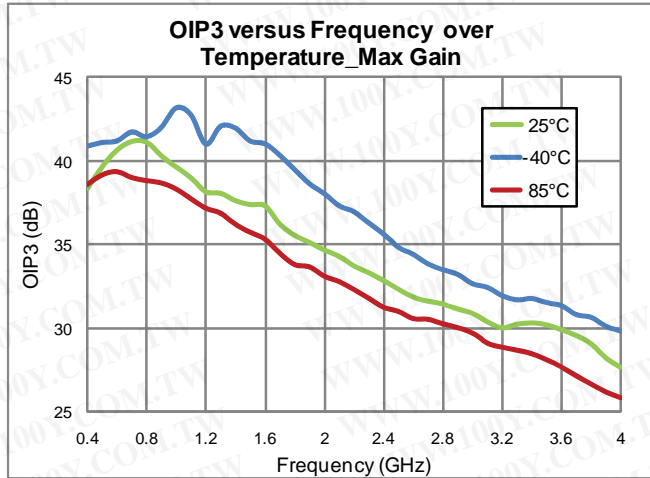

## Truth Table

Channel 1 Control Bit						Gain Relative to Maximum Gain
D11	D10	D9	D8	D7	D6	
1	1	1	1	1	1	0dB
1	1	1	1	1	0	-0.5dB
1	1	1	1	0	1	-1dB
1	1	1	0	1	1	-2dB
1	1	0	1	1	1	-4dB
1	0	1	1	1	1	-8dB
0	1	1	1	1	1	-16dB
0	0	0	0	0	0	-31.5dB

Channel 2 Control Bit						Gain Relative to Maximum Gain
D5	D4	D3	D2	D1	D0	
1	1	1	1	1	1	0dB
1	1	1	1	1	0	-0.5dB
1	1	1	1	0	1	-1dB
1	1	1	0	1	1	-2dB
1	1	0	1	1	1	-4dB
1	0	1	1	1	1	-8dB
0	1	1	1	1	1	-16dB
0	0	0	0	0	0	-31.5dB

Power-up Programming Truth Table	
PUP	Attenuator Setting
High	Attenuation at min, 0dB
Low	Attenuation at max, 31.5dB

Logic Voltage Levels	
State	Logic
Low	0V to 0.8V
High	2.0V to 5.0V

**Serial Port Interface**

**SPI Timing Diagram**

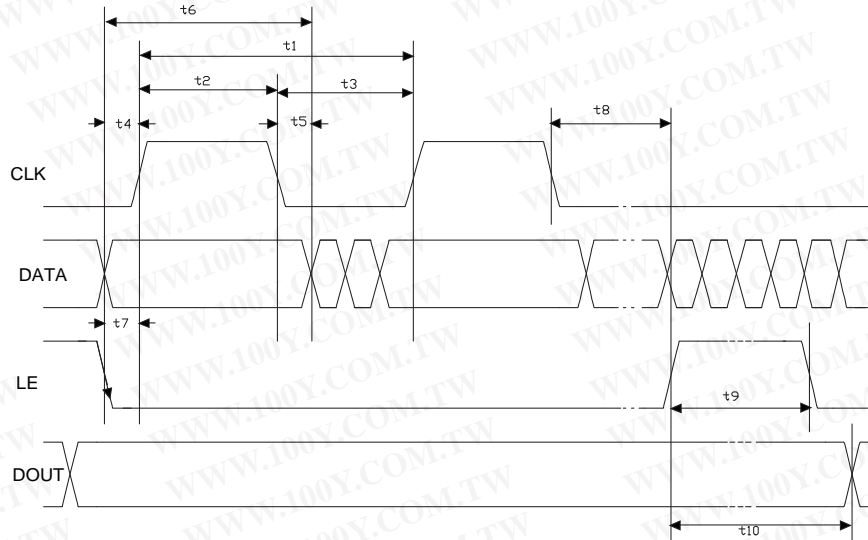

**Programming Example - 12 bit**

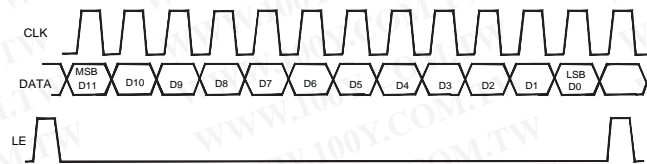

**SPI Timing Diagram Specifications**

Parameter	Limit	Unit	Comment
t1	25	MHz max	CLK Frequency
t2	20	ns min	CLK High
t3	20	ns min	CLK Low
t4	5	ns min	DATA to CLK Setup Time
t5	5	ns min	DATA to CLK Hold Time
t6	30	ns min	DATA Valid
t7	5	ns min	LE to CLK Setup Time
t8	5	ns min	CLK to LE Setup Time
t9	10	ns min	LE Pulse Width
t10	20	ns max	Output Set

## Pin Names and Descriptions

Pin	Name	Description
1	<b>RFIN_1</b>	AMP 1 RF Input
2	<b>GND</b>	RF/DC Ground Connection
3	<b>SPI_VCC</b>	Supply Voltage for SPI Chip
4	<b>SPI_LE</b>	Serial Latch Enable Input
5	<b>SPI_DATA</b>	Serial Data Input
6	<b>SPI_CLK</b>	Serial Clock Input
7	<b>PUP</b>	Power-up Programming Pin
8	<b>RFIN_2</b>	AMP 2 RF Input
9	<b>GND</b>	RF/DC Ground Connection
10	<b>DSA2_VCC</b>	Supply Voltage for DSA2 Chip
11	<b>GND</b>	RF/DC Ground Connection
12	<b>GND</b>	RF/DC Ground Connection
13	<b>NC</b>	No Connection
14	<b>GND</b>	RF/DC Ground Connection
15	<b>AMP2_VCC</b>	Supply Voltage for Amplifier 2
16	<b>GND</b>	RF/DC Ground Connection
17	<b>RFOUT_2</b>	AMP 2 RF Output
18	<b>GND</b>	RF/DC Ground Connection
19	<b>GND</b>	RF/DC Ground Connection
20	<b>GND</b>	RF/DC Ground Connection
21	<b>GND</b>	RF/DC Ground Connection
22	<b>GND</b>	RF/DC Ground Connection
23	<b>GND</b>	RF/DC Ground Connection
24	<b>RFOUT_1</b>	AMP 1 RF Output
25	<b>GND</b>	RF/DC Ground Connection
26	<b>AMP1_VCC</b>	Supply Voltage for Amplifier 1
27	<b>GND</b>	RF/DC Ground Connection
28	<b>NC</b>	No Connection
29	<b>GND</b>	RF/DC Ground Connection
30	<b>GND</b>	RF/DC Ground Connection
31	<b>DSA1_VCC</b>	Supply Voltage for DSA1 Chip
32	<b>GND</b>	RF/DC Ground Connection



## Evaluation Board Schematic 400MHz to 2700MHz Application Circuit

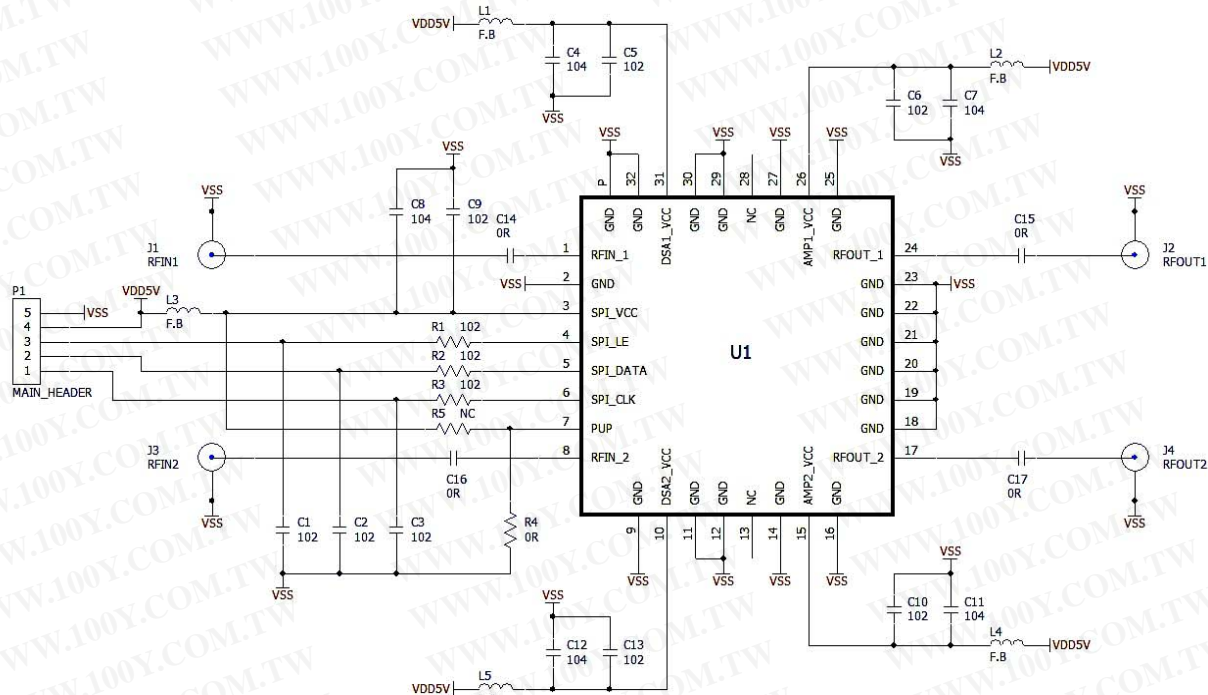

## Evaluation Board Build of Materials (BOM) 400MHz to 2700MHz Application Circuit

Description	Reference Designator	Manufacturer	Manufacturer's P/N
RFDAx0x7, PCB		DDI	RFDAx0x7410
RFDA0047SB	U1	RFMD	RFDA0047
RES, 0Ω, 0402	C14-C17, R5	Kamaya, Inc	RMC1/16SJPTH
CAP, 1000pF, 10%, 50V, X7R, 0402	C1-C3, C5-C6, C8-C10, C13	Murata Electronics	GRM155R71H102KA01E
CAP, 0.1μF, 10%, 16V, X7R, 0603	C4, C7, C11-C12	Murata Electronics	GRM188R71C104KA01D
FER, BEAD, 70Ω, 4A, 0603	L1-L5	Murata Electronics	BLM18SG700TN1D
RES, 1K, 5%, 1/16W, 0402	R1-R3	KOA Speer	RK73B1ETTP102J
CONN, SMA, END LNCH, RND PIN, 0.059"	J1-J4	Gigalane	PSF-S01-006
CONN, HDR, ST, PLRZD, 5-PIN, 0.100"	P1	ITW Pancon	MPSS100-5-C
DNP	R4, R6-R7, J5-J6, P2	N/A	N/A

## Evaluation Board Assembly Drawing 400MHz to 2700MHz Application Circuit

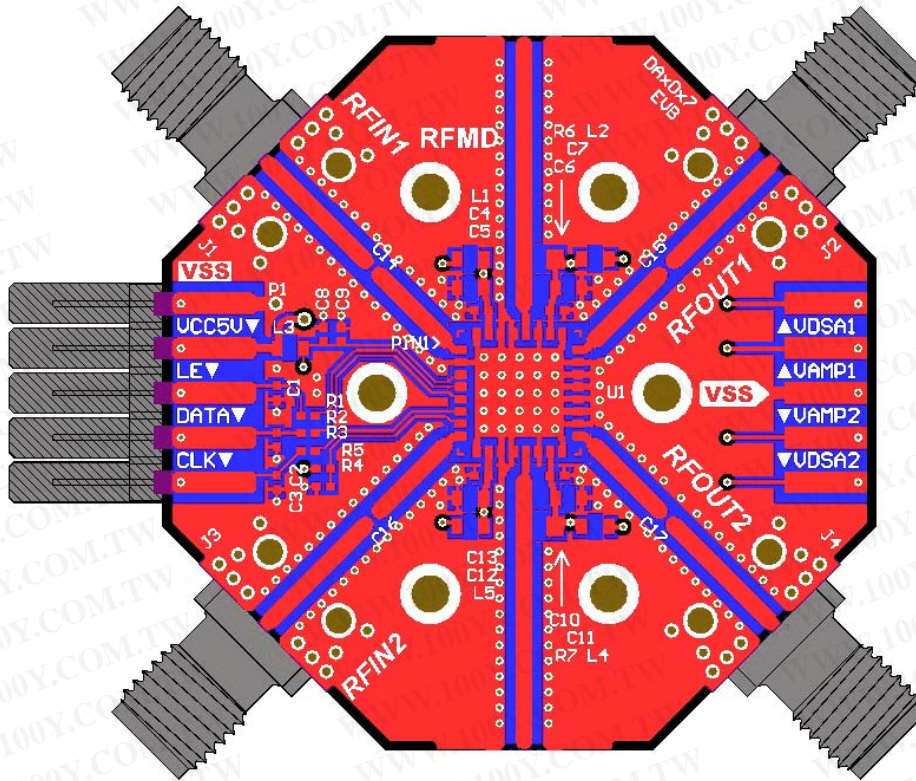

**Package Drawing**  
7.0mm x 7.0mm Laminate Module

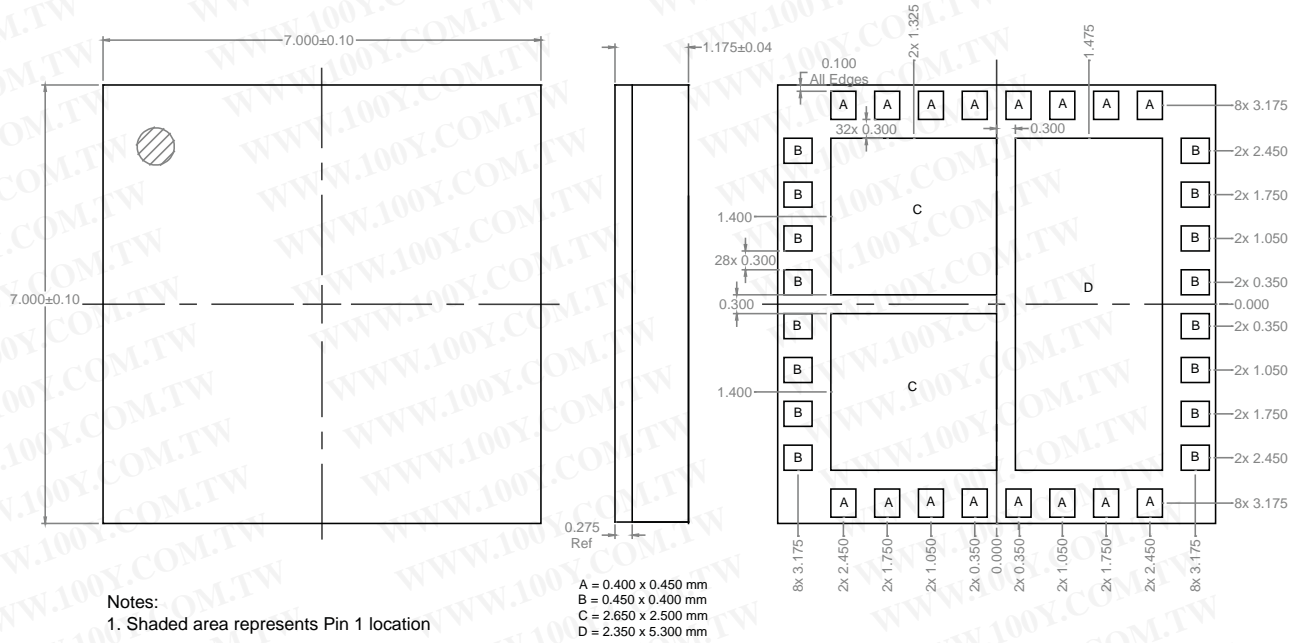

勝特力材料 886-3-5753170  
勝特力电子(上海) 86-21-34970699  
勝特力电子(深圳) 86-755-83298787  
[Http://www.100y.com.tw](http://www.100y.com.tw)