

STRUCTURE Silicon Monolithic Integrated Circuit  
 PRODUCT SERIES FM stereo transmitter IC for audio systems.

TYPE **BH1415FV**

- FEATURES
- It is possible to attempt to improve a timbre because it has the pre-emphasis circuit, limiter circuit and low-pass filter circuit.
  - Built-in the pilot-tone system FM stereo modulator circuit.
  - The transmission frequency is stable because it has PLL system FM transmitter circuit.
  - PLL data input (CE, CK, DA) by serial input.
  - It is possible for the monaural mode.
  - Built-in the sound muting circuit.

○ Absolute Maximum Ratings (Ta=25°C)

Parameter	Symbol	Limits	Unit	Conditions
Supply voltage	Vcc	+7.0	V	Pin8, 13
Data input voltage	V <sub>IN-D</sub>	-0.3 ~ VCC+0.3	V	Pin17, 18, 19, 20
Phase comparator output voltage	V <sub>OUT-P</sub>	-0.3 ~ VCC+0.3	V	Pin7
Power dissipation	Pd	630	mW	(*1)
Storage temperature	Tstg	-55 ~ +125	°C	

(\*1) To use at a temperature higher than Ta=25°C, derate 6.3mW per 1°C.

Status of this document

The Japanese version of this document is the formal specification. A customer may use this translation version only for a reference to help reading the formal version. If there are any differences in translation version of this document, formal version takes priority.

Application example

The application circuit is recommended for use. Make sure to confirm the adequacy of the characteristics.

When using the circuit with changes to the external circuit constants, make sure to leave an adequate margin for external components including static and transitional characteristics as well as dispersion of the IC.

Note that ROHM cannot provide adequate confirmation of patents.

The product described in this specification is designed to be used with ordinary electronic equipment or devices (such as audio-visual equipment, office-automation equipment, communications devices, electrical appliances, and electronic toys.)

Should you intend to use this product with equipment or devices which require an extremely high level of reliability and the malfunction of which would directly endanger human life (such as medical instruments, transportation equipment, aerospace machinery, nuclear-reactor controllers, fuel controllers and other safety devices), please be sure to consult with our sales representative in advance.

ROHM assumes no responsibility for the use of any circuits described herein, conveys no license under any patent or other right, and makes no representations that the circuits are free from patent infringement.

○ Operating Range

Parameter	Symbol	Limits	Unit	Conditions
Operating supply voltage	V <sub>CC</sub>	4.0 ~ 6.0	V	Pin 8, 13
Operating temperature	T <sub>opr</sub>	-40 ~ +85	°C	
Audio input level	V <sub>IN-A</sub>	~ -10	dBV	Pin 1, 24
Audio input frequency band	f <sub>IN-A</sub>	20 ~ 15k	Hz	Pin 1, 24
Pre-emphasis time constant set up range	τ <sub>PRE</sub>	~ 155	μ sec	Pin 2, 23
Transmission frequency	f <sub>TX</sub>	70 ~ 120	MHz	Pin 10, 12
Control terminal "H" level input voltage	V <sub>IH</sub>	0.8V <sub>CC</sub> ~ V <sub>CC</sub>	V	Pin 17, 18, 19, 20
Control terminal "L" level input voltage	V <sub>IL</sub>	GND ~ 0.2V <sub>CC</sub>	V	Pin 17, 18, 19, 20

○ Electrical Characteristics

Unless otherwise specified Ta=25°C , V<sub>CC</sub>=5.0V

Signal source : f<sub>IN</sub>=400Hz

Parameter	Symbol	Limits			Unit	Conditions
		Min.	Typ.	Max.		
Quiescent current	I <sub>Q</sub>	14	20	28	mA	
Channel separation	Sep	25	40	—	dB	V <sub>IN</sub> =-20dBV, L→R, R→L
Total harmonic distortion	THD	—	0.1	0.3	%	V <sub>IN</sub> =-20dBV, L+R
Channel balance	C.B	-2	0	+2	dB	V <sub>IN</sub> =-20dBV, L+R
Input output gain	G <sub>V</sub>	-2	0	+2	dB	V <sub>IN</sub> =-20dBV, L+R
Pilot modulation rate	M <sub>P</sub>	12	15	18	%	V <sub>IN</sub> =-20dBV, L+R, Pin5
Sub carrier rejection ratio	SCR	—	-30	-20	dB	V <sub>IN</sub> =-20dBV, L+R
Pre-emphasis time constant	τ <sub>PRE</sub>	40	50	60	μ sec	V <sub>IN</sub> =-20dBV, L+R
Limiter input level	V <sub>IN(LIM)</sub>	-16	-13	-10	dBV	Output level at 1dB gain compression
LPF cut off frequency	f <sub>C(LPF)</sub>	12	15	18	kHz	V <sub>O</sub> =-3dB, Pin2, 23 Open
Mute attenuation volume	V <sub>O(MUTE)</sub>	—	-48	-42	dB	V <sub>IN</sub> =-20dBV, L+R
Transmission output level	V <sub>TX</sub>	97	100	103	dB μ V	f <sub>TX</sub> =100MHz
"H" level input current	I <sub>IH</sub>	—	—	1.0	μ A	Pin 17, 18, 19, 20 V <sub>IN</sub> =5V
"L" level input current	I <sub>IL</sub>	-1.0	—	—	μ A	Pin 17, 18, 19, 20 V <sub>IN</sub> =0V
"H" level output voltage	V <sub>OH</sub>	V <sub>CC</sub> -1.0	V <sub>CC</sub> -0.15	—	V	Pin 7 I <sub>OUT</sub> =- 1.0mA
"L" level output voltage	V <sub>OL</sub>	—	0.15	1.0	V	Pin 7 I <sub>OUT</sub> =1.0mA
"off" level leak current 1	I <sub>OFF1</sub>	—	—	100	nA	Pin 7 V <sub>OUT</sub> =5V
"off" level leak current 2	I <sub>OFF2</sub>	-100	—	—	nA	Pin 7 V <sub>OUT</sub> =GND

© This product is not designed for protection against radioactive rays.

© The specification of transmission output level be based on the Radio Law in every country and the area.

○ External Dimension Diagram • Marking Diagram

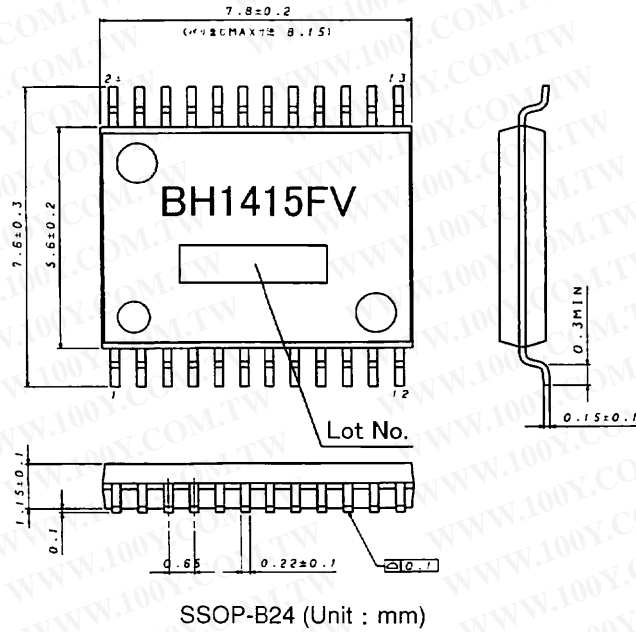

○ Block Diagram

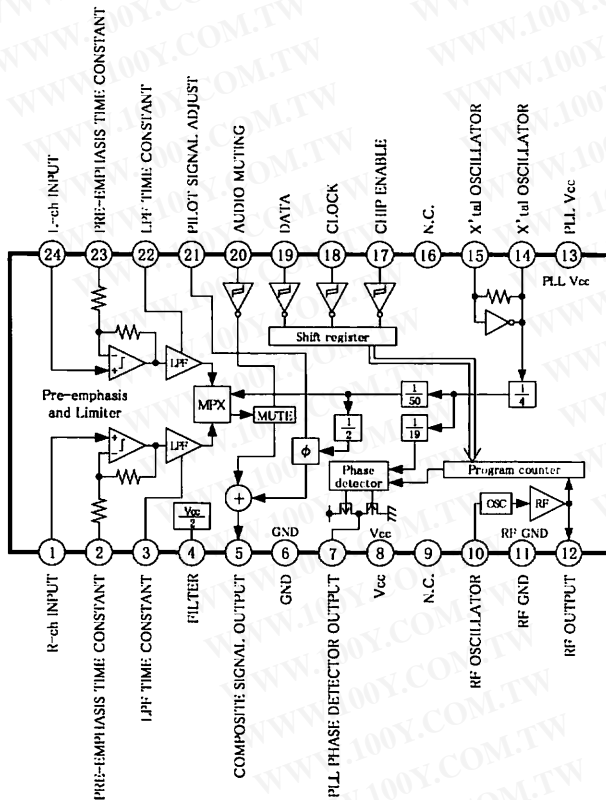

○ Pin No. • Pin Name

No.	Name	No.	Name
1	R-ch INPUT	13	PLL Vcc
2	PRE-EMPHASIS TIME CONSTANT	14	X'tal OSCILLATOR
3	LPF TIME CONSTANT	15	X'tal OSCILLATOR
4	FILTER	16	N.C.
5	COMPOSITE SIGNAL OUTPUT	17	CHIP ENABLE
6	GND	18	CLOCK
7	PLL PHASE DETECTOR OUTPUT	19	DATA
8	Vcc	20	AUDIO MUTING
9	N.C.	21	PILOT SIGNAL ADJUST
10	RF OSCILLATOR	22	LPF TIME CONSTANT
11	RF GND	23	PRE-EMPHASIS TIME CONSTANT
12	RF OUTPUT	24	L-ch INPUT

○ Cautions On Use

(1) Absolute maximum ratings

If applied voltage, operating temperature range, or other absolute maximum ratings are exceeded, the LSI may be damaged. Do not apply voltages or temperatures that exceed the absolute maximum ratings. If you think of a case in which absolute maximum ratings are exceeded, enforce fuses or other physical safety measures and investigate how not to apply the conditions under which absolute maximum ratings are exceeded to the LSI.

(2) GND potential

Make the GND pin voltage such that it is the lowest voltage even when operating below it. Actually confirm that the voltage of each pin does not become a lower voltage than the GND pin, including transient phenomena.

(3) Thermal design

Perform thermal design in which there are adequate margins by taking into account the allowable power dissipation in actual states of use.

(4) Shorts between pins and misinstallation

When mounting the LSI on a board, pay adequate attention to orientation and placement discrepancies of the LSI. If it is misinstalled and the power is turned on, the LSI may be damaged. It also may be damaged if it is shorted by a foreign substance coming between pins of the LSI or between a pin and a power supply or a pin and a GND.

(5) Operation in strong magnetic fields

Adequately evaluate use in a strong magnetic field, since there is a possibility of malfunction.

### Notes

- No technical content pages of this document may be reproduced in any form or transmitted by any means without prior permission of ROHM CO.,LTD.
- The contents described herein are subject to change without notice. The specifications for the product described in this document are for reference only. Upon actual use, therefore, please request that specifications to be separately delivered.
- Application circuit diagrams and circuit constants contained herein are shown as examples of standard use and operation. Please pay careful attention to the peripheral conditions when designing circuits and deciding upon circuit constants in the set.
- Any data, including, but not limited to application circuit diagrams information, described herein are intended only as illustrations of such devices and not as the specifications for such devices. ROHM CO.,LTD. disclaims any warranty that any use of such devices shall be free from infringement of any third party's intellectual property rights or other proprietary rights, and further, assumes no liability of whatsoever nature in the event of any such infringement, or arising from or connected with or related to the use of such devices.
- Upon the sale of any such devices, other than for buyer's right to use such devices itself, resell or otherwise dispose of the same, no express or implied right or license to practice or commercially exploit any intellectual property rights or other proprietary rights owned or controlled by
- ROHM CO., LTD. is granted to any such buyer.
- Products listed in this document are no antiradiation design.

The products listed in this document are designed to be used with ordinary electronic equipment or devices (such as audio visual equipment, office-automation equipment, communications devices, electrical appliances and electronic toys).

Should you intend to use these products with equipment or devices which require an extremely high level of reliability and the malfunction of which would directly endanger human life (such as medical instruments, transportation equipment, aerospace machinery, nuclear-reactor controllers, fuel controllers and other safety devices), please be sure to consult with our sales representative in advance.

#### About Export Control Order in Japan

Products described herein are the objects of controlled goods in Annex 1 (Item 16) of Export Trade Control Order in Japan.

In case of export from Japan, please confirm if it applies to "objective" criteria or an "informed" (by MITI clause) on the basis of "catch all controls for Non-Proliferation of Weapons of Mass Destruction.