



# S-89110/89120 Series

## MINI ANALOG SERIES CMOS OPERATIONAL AMPLIFIER

[www.sii-ic.com](http://www.sii-ic.com)

© SII Semiconductor Corporation, 2009-2015

Rev.3.1\_01

The mini-analog series is a group of ICs that incorporate a general purpose analog circuit in a small package. The S-89110/89120 Series is a CMOS type operational amplifier that has a phase compensation circuit, and operates at a low voltage with low current consumption. These features make this product the ideal solution for small battery-powered portable equipment.

The S-89110A/89120A Series is a single operational amplifier (one circuit).

The S-89110B/89120B Series is a dual operational amplifier (two circuits).

勝特力材料 886-3-5753170  
勝特力电子(上海) 86-21-34970699  
勝特力电子(深圳) 86-755-83298787  
[Http://www.100y.com.tw](http://www.100y.com.tw)

### ■ Features

- Lower operating voltage than the conventional general-purpose:  
 $V_{DD} = 1.8\text{ V to }5.5\text{ V}$
- Low current consumption (per circuit):  
 $I_{DD} = 50\ \mu\text{A}$  (S-89110 Series)  
 $I_{DD} = 10\ \mu\text{A}$  (S-89120 Series)
- Low input offset voltage: 4.0 mV max.
- No external capacitors required for internal phase compensation
- Output full swing
- Lead-free, Sn 100%, halogen-free\*1

\*1. Refer to "■ Product Name Structure" for details.

### ■ Applications

- Mobile phone
- Notebook PC
- Digital camera
- Digital video camera

### ■ Packages

- SC-88A
- SOT-23-5
- SNT-8A
- TMSOP-8

■ Block Diagrams

1. S-89110A/89120A Series single operational amplifier (one circuit)

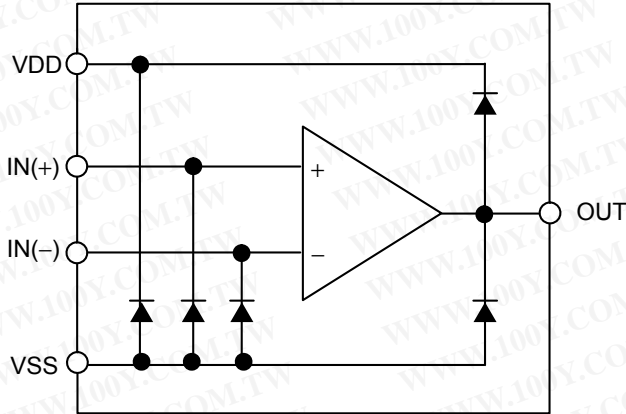

Figure 1

2. S-89110B/89120B Series dual operational amplifier (two circuits)

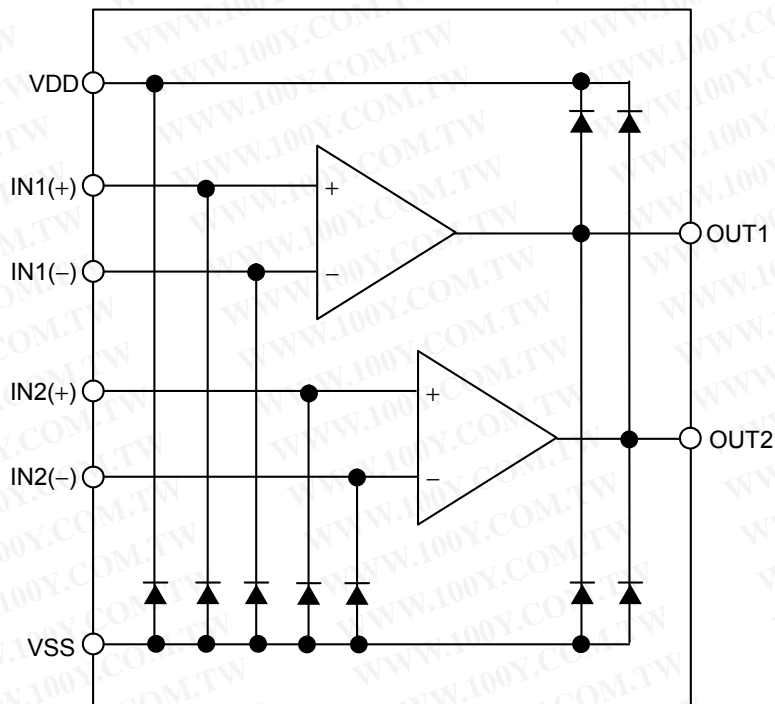

Figure 2

■ **Product Name Structure**

Users can select the product type for the S-89110/89120 Series. Refer to "1. Product name" regarding the contents of product name, "2. Packages" regarding the package drawings and "3. Product name list" regarding the product type.

**1. Product name**

**1.1 SC-88A**

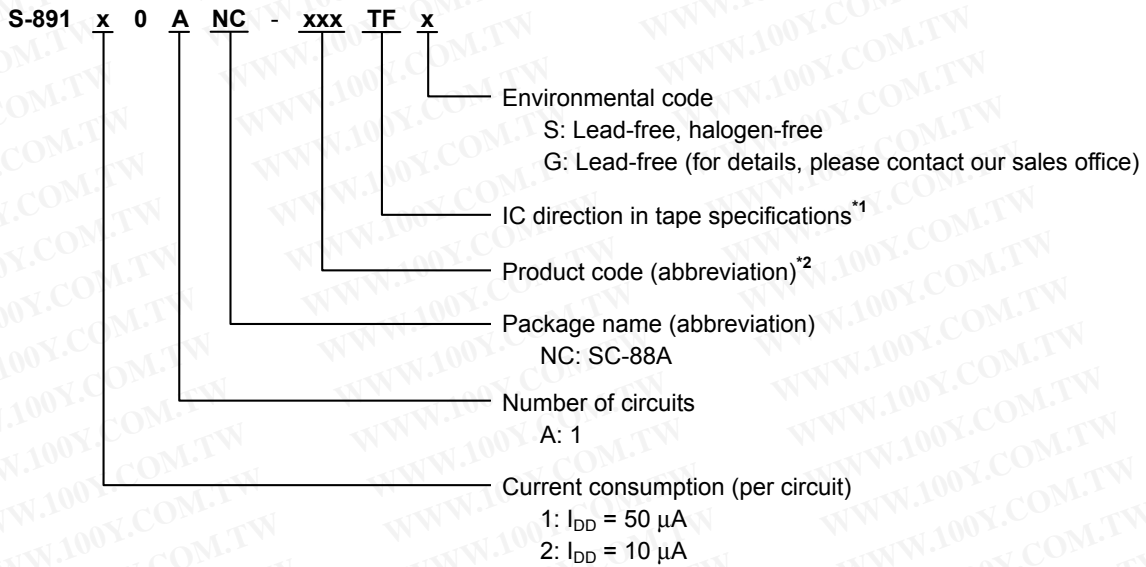

\*1. Refer to the tape drawing.

\*2. Refer to "3. Product name list".

**1.2 SOT-23-5**

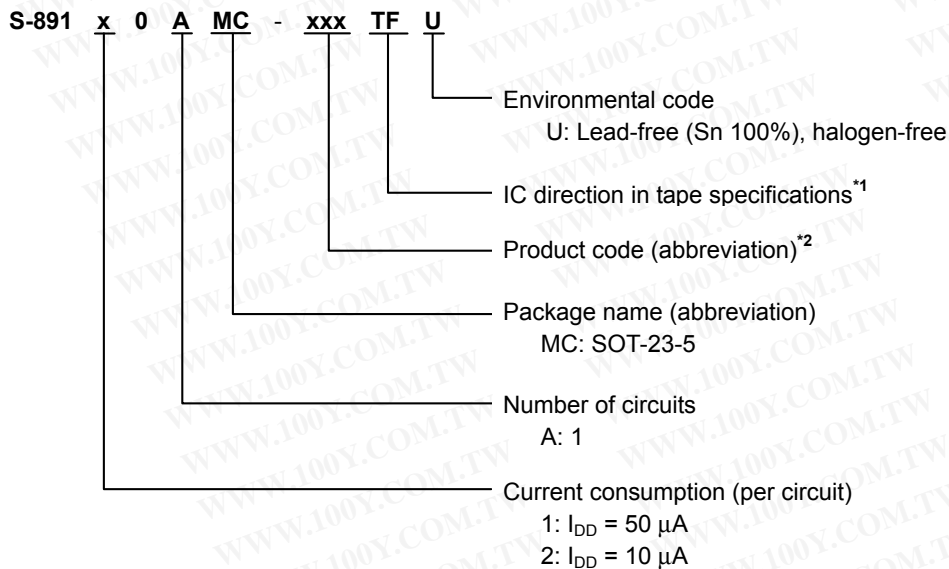

\*1. Refer to the tape drawing.

\*2. Refer to "3. Product name list".

**1.3 SNT-8A, TMSOP-8**

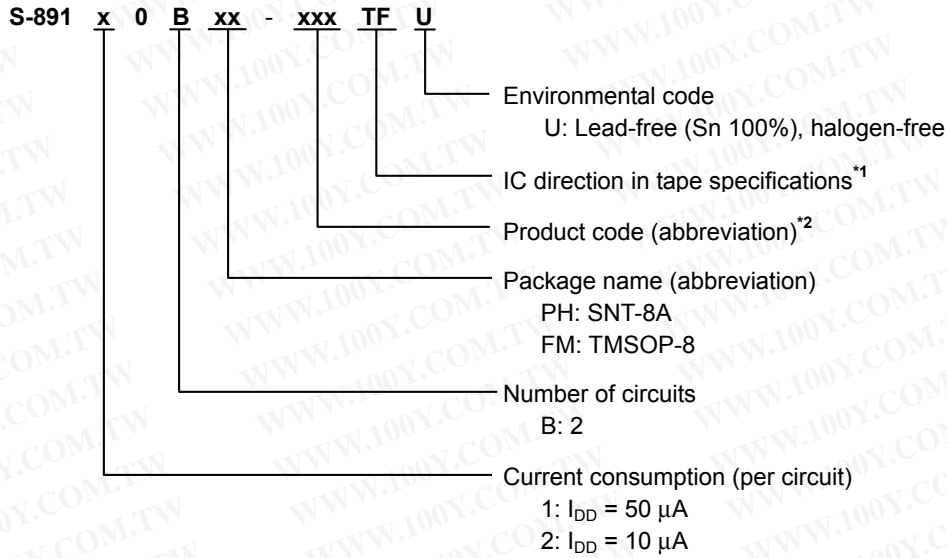

\*1. Refer to the tape drawing.

\*2. Refer to "3. Product name list".

**2. Packages**

**Table 1 Package Drawing Codes**

Package Name	Dimension	Tape	Reel	Land
SC-88A	NP005-B-P-SD	NP005-B-C-SD	NP005-B-R-SD	—
SOT-23-5	MP005-A-P-SD	MP005-A-C-SD	MP005-A-R-SD	—
SNT-8A	PH008-A-P-SD	PH008-A-C-SD	PH008-A-R-SD	PH008-A-L-SD
TMSOP-8	FM008-A-P-SD	FM008-A-C-SD	FM008-A-R-SD	—

**3. Product name list**

**Table 2**

Product Name	Current Consumption (per circuit)	Gain-bandwidth*1	Number of Circuit	Package
S-89110ANC-1A1-TFz	50 $\mu A$	175 kHz	1	SC-88A
S-89110AMC-1A1-TFU	50 $\mu A$	175 kHz	1	SOT-23-5
S-89110BPH-H4A-TFU	50 $\mu A$	175 kHz	2	SNT-8A
S-89110BFM-H4A-TFU	50 $\mu A$	175 kHz	2	TMSOP-8
S-89120ANC-1A2-TFz	10 $\mu A$	35 kHz	1	SC-88A
S-89120AMC-1A2-TFU	10 $\mu A$	35 kHz	1	SOT-23-5
S-89120BPH-H4B-TFU	10 $\mu A$	35 kHz	2	SNT-8A
S-89120BFM-H4B-TFU	10 $\mu A$	35 kHz	2	TMSOP-8

\*1. The value when  $V_{DD} = 3.0 V$

**Remark 1.** z: G or S

2. Please select products of environmental code = U for Sn 100%, halogen-free products.

**Pin Configurations**

**1. SC-88A**

Top view

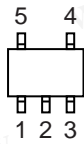

**Figure 3**

**Table 3**

(Product with 1 circuit)

Pin No.	Symbol	Description
1	IN(+)	Non-inverted input pin
2	VSS	GND pin
3	IN(-)	Inverted input pin
4	OUT	Output pin
5	VDD	Positive power supply pin

**2. SOT-23-5**

Top view

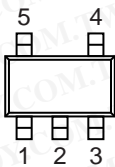

**Figure 4**

**Table 4**

(Product with 1 circuit)

Pin No.	Symbol	Description
1	IN(+)	Non-inverted input pin
2	VSS	GND pin
3	IN(-)	Inverted input pin
4	OUT	Output pin
5	VDD	Positive power supply pin

**3. SNT-8A**

Top view

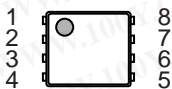

**Figure 5**

**Table 5**

(Product with 2 circuits)

Pin No.	Symbol	Description
1	OUT1	Output pin 1
2	IN1(-)	Inverted input pin 1
3	IN1(+)	Non-inverted input pin 1
4	VSS	GND pin
5	IN2(+)	Non-inverted input pin 2
6	IN2(-)	Inverted input pin 2
7	OUT2	Output pin 2
8	VDD	Positive power supply pin

**4. TMSOP-8**

Top view

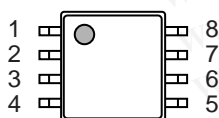

**Figure 6**

**Table 6**

(Product with 2 circuits)

Pin No.	Symbol	Description
1	OUT1	Output pin 1
2	IN1(-)	Inverted input pin 1
3	IN1(+)	Non-inverted input pin 1
4	VSS	GND pin
5	IN2(+)	Non-inverted input pin 2
6	IN2(-)	Inverted input pin 2
7	OUT2	Output pin 2
8	VDD	Positive power supply pin

■ Absolute Maximum Ratings

Table 7

(Ta = +25°C unless otherwise specified)

Item	Symbol	Absolute Maximum Rating	Unit
Power supply voltage	V <sub>DD</sub>	V <sub>SS</sub> - 0.3 to V <sub>SS</sub> + 10.0	V
Input voltage	V <sub>IN</sub>	V <sub>SS</sub> - 0.3 to V <sub>SS</sub> + 7.0 (7.0 max.)	V
Output voltage	V <sub>OUT</sub>	V <sub>SS</sub> - 0.3 to V <sub>DD</sub> + 0.3 (7.0 max.)	V
Differential input voltage	V <sub>IND</sub>	±7.0	V
Output pin current	I <sub>SINK</sub>	13	mA
	I <sub>SOURCE</sub>	9	mA
Power dissipation	SC-88A	350*1	mW
	SOT-23-5	600*1	mW
	SNT-8A	450*1	mW
	TMSOP-8	650*1	mW
Operating ambient temperature	T <sub>opr</sub>	-40 to +85	°C
Storage temperature	T <sub>stg</sub>	-55 to +125	°C

\*1. When mounted on board  
[Mounted board]

- (1) Board size: 114.3 mm × 76.2 mm × 1.6 mm
- (2) Board name: JEDEC STANDARD51-7

**Caution** The absolute maximum ratings are rated values exceeding which the product could suffer physical damage. These values must therefore not be exceeded under any conditions.

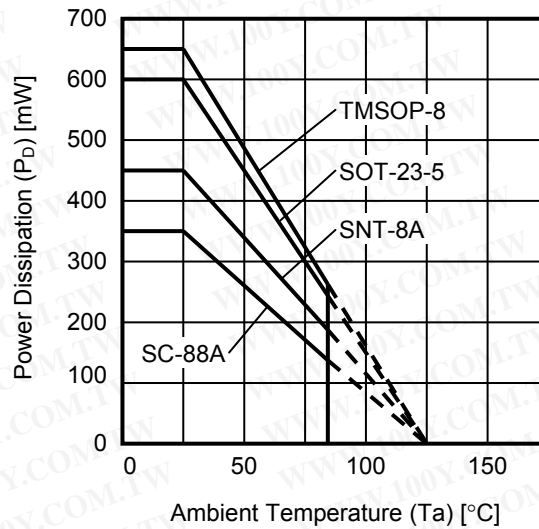

Figure 7 Power Dissipation of Package (When Mounted on Board)

# MINI ANALOG SERIES CMOS OPERATIONAL AMPLIFIER

## S-89110/89120 Series

Rev.3.1\_01

### ■ Electrical Characteristics

**Table 8**

(Ta = +25°C unless otherwise specified)

Item	Symbol	Condition	Min.	Typ.	Max.	Unit	Test Circuit
Range of operating power supply voltage	V <sub>DD</sub>	–	1.8	–	5.5	V	–

#### 1. V<sub>DD</sub> = 5.0 V

**Table 9**

(Ta = +25°C unless otherwise specified)

#### DC Electrical Characteristics (V<sub>DD</sub> = 5.0 V)

Item	Symbol	Condition	Min.	Typ.	Max.	Unit	Test Circuit	
Current consumption (per circuit)	I <sub>DD</sub>	S-89110 Series	–	50	120	μA	5	
		S-89120 Series	–	10	30	μA	5	
Input offset voltage	V <sub>IO</sub>	–	–4	±3	+4	mV	1	
Input offset voltage drift	$\frac{\Delta V_{IO}}{\Delta T_a}$	Ta = –40°C to +85°C	–	±10	–	μV/°C	1	
Input offset current	I <sub>IO</sub>	–	–	1	–	pA	–	
Input bias current	I <sub>BIAS</sub>	–	–	1	–	pA	–	
Common-mode input voltage range	V <sub>CMR</sub>	–	0	–	4.3	V	2	
Voltage gain (open loop)	A <sub>VOL</sub>	V <sub>SS</sub> + 0.5 V ≤ V <sub>OUT</sub> ≤ V <sub>DD</sub> – 0.5 V, V <sub>CMR</sub> = 2.5 V	70	80	–	dB	8	
Maximum output swing voltage	V <sub>OH</sub>	R <sub>L</sub> = 1.0 MΩ	4.9	–	–	V	3	
	V <sub>OL</sub>	R <sub>L</sub> = 1.0 MΩ	–	–	0.1	V	4	
Common-mode input signal rejection ratio	CMRR	–	60	70	–	dB	2	
Power supply voltage rejection ratio	PSRR	–	60	70	–	dB	1	
Source current	I <sub>SOURCE</sub>	V <sub>OUT</sub> = 0 V	S-89110 Series	120	–	–	μA	6
			S-89120 Series	25	–	–	μA	6
Sink current	I <sub>SINK</sub>	V <sub>OUT</sub> = 0.5 V	9	–	–	mA	7	

**Table 10**

(Ta = +25°C unless otherwise specified)

#### AC Electrical Characteristics (V<sub>DD</sub> = 5.0 V)

Item	Symbol	Condition	Min.	Typ.	Max.	Unit	
Slew rate	SR	R <sub>L</sub> = 1.0 MΩ, C <sub>L</sub> = 15 pF (Refer to <b>Figure 16</b> )	S-89110 Series	–	0.07	–	V/μs
			S-89120 Series	–	0.015	–	V/μs
Gain-bandwidth product	GBP	S-89110 Series	–	180	–	kHz	
		S-89120 Series	–	40	–	kHz	

**2.  $V_{DD} = 3.0\text{ V}$**

**Table 11**

**DC Electrical Characteristics ( $V_{DD} = 3.0\text{ V}$ )** (Ta = +25°C unless otherwise specified)

Item	Symbol	Condition	Min.	Typ.	Max.	Unit	Test Circuit	
Current consumption (per circuit)	$I_{DD}$	S-89110 Series	–	50	120	$\mu\text{A}$	5	
		S-89120 Series	–	10	30	$\mu\text{A}$	5	
Input offset voltage	$V_{IO}$	–	–4	$\pm 3$	+4	mV	1	
Input offset voltage drift	$\frac{\Delta V_{IO}}{\Delta T_a}$	Ta = –40°C to +85°C	–	$\pm 10$	–	$\mu\text{V}/^\circ\text{C}$	1	
Input offset current	$I_{IO}$	–	–	1	–	pA	–	
Input bias current	$I_{BIAS}$	–	–	1	–	pA	–	
Common-mode input voltage range	$V_{CMR}$	–	0	–	2.3	V	2	
Voltage gain (open loop)	$A_{VOL}$	$V_{SS} + 0.5\text{ V} \leq V_{OUT} \leq V_{DD} - 0.5\text{ V}$ , $V_{CMR} = 1.5\text{ V}$	70	80	–	dB	8	
Maximum output swing voltage	$V_{OH}$	$R_L = 1.0\text{ M}\Omega$	2.9	–	–	V	3	
	$V_{OL}$	$R_L = 1.0\text{ M}\Omega$	–	–	0.1	V	4	
Common-mode input signal rejection ratio	CMRR	–	60	70	–	dB	2	
Power supply voltage rejection ratio	PSRR	–	60	70	–	dB	1	
Source current	$I_{SOURCE}$	$V_{OUT} = 0\text{ V}$	S-89110 Series	120	–	–	$\mu\text{A}$	6
			S-89120 Series	25	–	–	$\mu\text{A}$	6
Sink current	$I_{SINK}$	$V_{OUT} = 0.5\text{ V}$	8	–	–	mA	7	

**Table 12**

**AC Electrical Characteristics ( $V_{DD} = 3.0\text{ V}$ )** (Ta = +25°C unless otherwise specified)

Item	Symbol	Condition	Min.	Typ.	Max.	Unit	
Slew rate	SR	$R_L = 1.0\text{ M}\Omega$ , $C_L = 15\text{ pF}$ (Refer to <b>Figure 16</b> )	S-89110 Series	–	0.07	–	V/ $\mu\text{s}$
			S-89120 Series	–	0.015	–	V/ $\mu\text{s}$
Gain-bandwidth product	GBP	S-89110 Series	–	175	–	kHz	
		S-89120 Series	–	35	–	kHz	



**MINI ANALOG SERIES CMOS OPERATIONAL AMPLIFIER**  
**S-89110/89120 Series**

Rev.3.1\_01

**3.  $V_{DD} = 1.8\text{ V}$**

**Table 13**

**DC Electrical Characteristics ( $V_{DD} = 1.8\text{ V}$ )** ( $T_a = +25^\circ\text{C}$  unless otherwise specified)

Item	Symbol	Condition	Min.	Typ.	Max.	Unit	Test Circuit	
Current consumption (per circuit)	$I_{DD}$	S-89110 Series	–	50	120	$\mu\text{A}$	5	
		S-89120 Series	–	10	30	$\mu\text{A}$	5	
Input offset voltage	$V_{IO}$	–	–4	$\pm 3$	+4	mV	1	
Input offset voltage drift	$\frac{\Delta V_{IO}}{\Delta T_a}$	$T_a = -40^\circ\text{C}$ to $+85^\circ\text{C}$	–	$\pm 10$	–	$\mu\text{V}/^\circ\text{C}$	1	
Input offset current	$I_{IO}$	–	–	1	–	pA	–	
Input bias current	$I_{BIAS}$	–	–	1	–	pA	–	
Common-mode input voltage range	$V_{CMR}$	–	0	–	1.1	V	2	
Voltage gain (open loop)	$A_{VOL}$	$V_{SS} + 0.5\text{ V} \leq V_{OUT} \leq V_{DD} - 0.5\text{ V}$ , $V_{CMR} = 0.9\text{ V}$	70	80	–	dB	8	
Maximum output swing voltage	$V_{OH}$	$R_L = 1.0\text{ M}\Omega$	1.7	–	–	V	3	
	$V_{OL}$	$R_L = 1.0\text{ M}\Omega$	–	–	0.1	V	4	
Common-mode input signal rejection ratio	CMRR	–	60	70	–	dB	2	
Power supply voltage rejection ratio	PSRR	–	60	70	–	dB	1	
Source current	$I_{SOURCE}$	$V_{OUT} = 0\text{ V}$	S-89110 Series	100	–	–	$\mu\text{A}$	6
			S-89120 Series	20	–	–	$\mu\text{A}$	6
Sink current	$I_{SINK}$	$V_{OUT} = 0.5\text{ V}$	5	–	–	mA	7	

**Table 14**

**AC Electrical Characteristics ( $V_{DD} = 1.8\text{ V}$ )** ( $T_a = +25^\circ\text{C}$  unless otherwise specified)

Item	Symbol	Condition	Min.	Typ.	Max.	Unit	
Slew rate	SR	$R_L = 1.0\text{ M}\Omega$ , $C_L = 15\text{ pF}$ (Refer to <b>Figure 16</b> )	S-89110 Series	–	0.07	–	$\text{V}/\mu\text{s}$
			S-89120 Series	–	0.015	–	$\text{V}/\mu\text{s}$
Gain-bandwidth product	GBP	S-89110 Series	–	160	–	kHz	
		S-89120 Series	–	30	–	kHz	

■ Test Circuit (Per Circuit)

1. Power supply voltage rejection ratio, input offset voltage

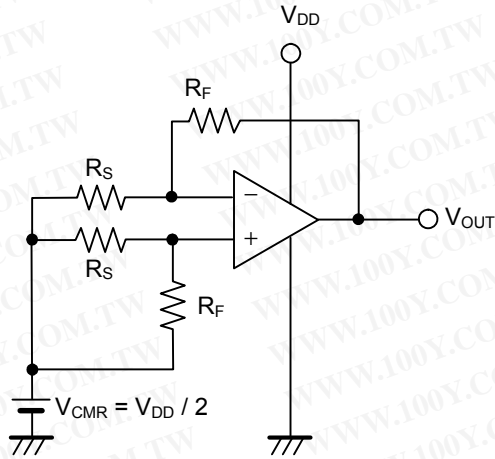

Figure 8

• Power supply voltage rejection ratio (PSRR)

The power supply voltage rejection ratio (PSRR) can be calculated by the following expression, with  $V_{OUT}$  measured at each  $V_{DD}$ .

Test conditions:

When  $V_{DD} = 1.8\text{ V}$ :  $V_{DD} = V_{DD1}$ ,  $V_{OUT} = V_{OUT1}$ ,

When  $V_{DD} = 5.0\text{ V}$ :  $V_{DD} = V_{DD2}$ ,  $V_{OUT} = V_{OUT2}$

$$PSRR = 20 \log \left( \left| \frac{V_{DD1} - V_{DD2}}{\left( V_{OUT1} - \frac{V_{DD1}}{2} \right) - \left( V_{OUT2} - \frac{V_{DD2}}{2} \right)} \right| \times \frac{R_F + R_S}{R_S} \right)$$

• Input offset voltage ( $V_{IO}$ )

$$V_{IO} = \left( V_{OUT} - \frac{V_{DD}}{2} \right) \times \frac{R_S}{R_F + R_S}$$

2. Common-mode input signal rejection ratio, common-mode input voltage range

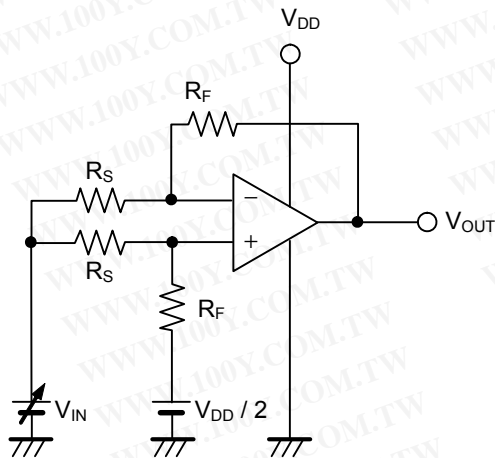

Figure 9

• Common-mode input signal rejection ratio (CMRR)

The common-mode input signal rejection ratio (CMRR) can be calculated by the following expression, with  $V_{OUT}$  measured at each  $V_{IN}$ .

Test conditions:

When  $V_{IN} = V_{CMR\ Max.}$ :  $V_{IN} = V_{IN1}$ ,  $V_{OUT} = V_{OUT1}$ ,

When  $V_{IN} = V_{DD} / 2$ :  $V_{IN} = V_{IN2}$ ,  $V_{OUT} = V_{OUT2}$

$$CMRR = 20 \log \left( \left| \frac{V_{IN1} - V_{IN2}}{V_{OUT1} - V_{OUT2}} \right| \times \frac{R_F + R_S}{R_S} \right)$$

• Common-mode input voltage range ( $V_{CMR}$ )

The common-mode input voltage range is the range of  $V_{IN}$  in which  $V_{OUT}$  satisfies the common-mode input signal rejection ratio specifications.

3. Maximum output swing voltage ( $V_{OH}$ )

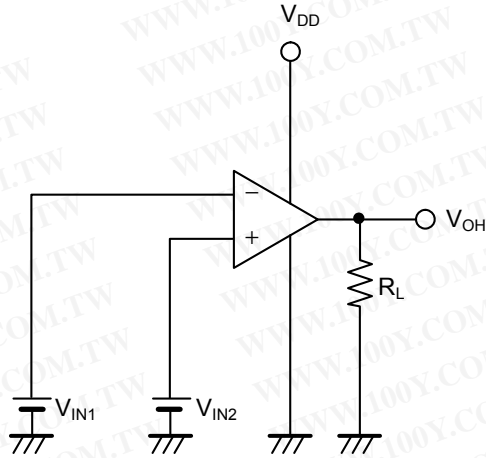

Figure 10

• Maximum output swing voltage ( $V_{OH}$ )

Test conditions:

$$V_{IN1} = \frac{V_{DD}}{2} - 0.1 \text{ V}$$

$$V_{IN2} = \frac{V_{DD}}{2} + 0.1 \text{ V}$$

$$R_L = 1 \text{ M}\Omega$$

4. Maximum output swing voltage ( $V_{OL}$ )

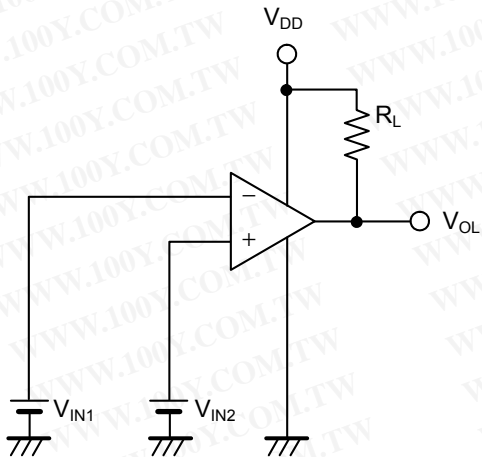

Figure 11

• Maximum output swing voltage ( $V_{OL}$ )

Test conditions:

$$V_{IN1} = \frac{V_{DD}}{2} + 0.1 \text{ V}$$

$$V_{IN2} = \frac{V_{DD}}{2} - 0.1 \text{ V}$$

$$R_L = 1 \text{ M}\Omega$$

5. Current consumption

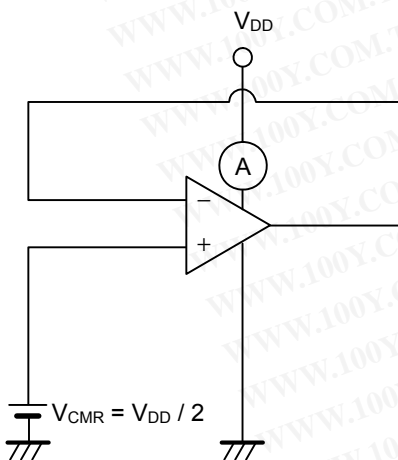

Figure 12

• Current consumption ( $I_{DD}$ )

6. Source current

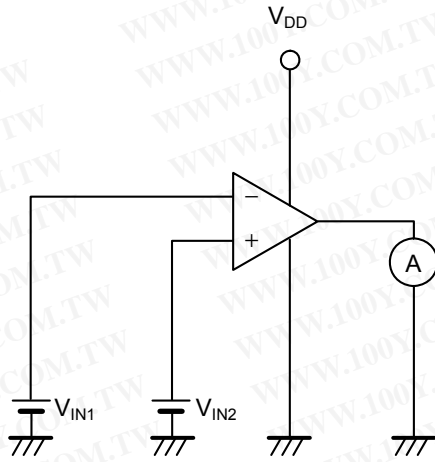

Figure 13

• Source current ( $I_{SOURCE}$ )

Test conditions:

$$V_{IN1} = \frac{V_{DD}}{2} - 0.5 \text{ V}$$

$$V_{IN2} = \frac{V_{DD}}{2} + 0.5 \text{ V}$$

7. Sink current

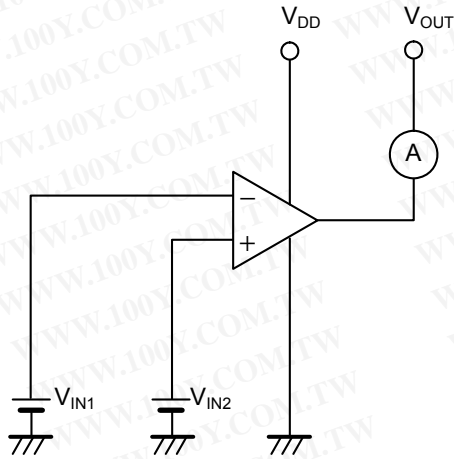

Figure 14

• Sink current ( $I_{SINK}$ )

Test conditions:

$$V_{OUT} = V_{SS} + 0.5 \text{ V}$$

$$V_{IN1} = \frac{V_{DD}}{2} + 0.5 \text{ V}$$

$$V_{IN2} = \frac{V_{DD}}{2} - 0.5 \text{ V}$$

8. Voltage gain (open loop)

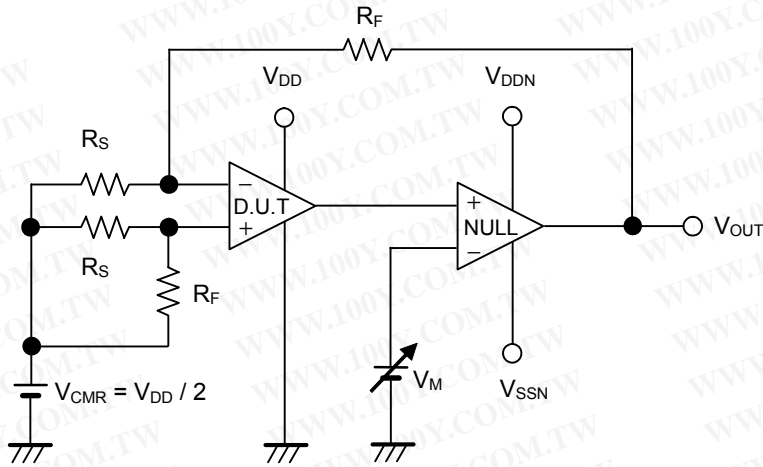

Figure 15

• Voltage-gain (open loop) ( $A_{VOL}$ )

The voltage gain ( $A_{VOL}$ ) can be calculated by the following expression, with  $V_{OUT}$  measured at each  $V_M$ .

Test conditions:

When  $V_M = V_{DD} - 0.5 V$ :  $V_M = V_{M1}$ ,  $V_{OUT} = V_{OUT1}$ ,

When  $V_M = V_{SS} + 0.5 V$ :  $V_M = V_{M2}$ ,  $V_{OUT} = V_{OUT2}$

$$A_{VOL} = 20 \log \left( \left| \frac{V_{M1} - V_{M2}}{V_{OUT1} - V_{OUT2}} \right| \times \frac{R_F + R_S}{R_S} \right)$$

9. Slew rate (SR)

Measured by the voltage follower circuit.

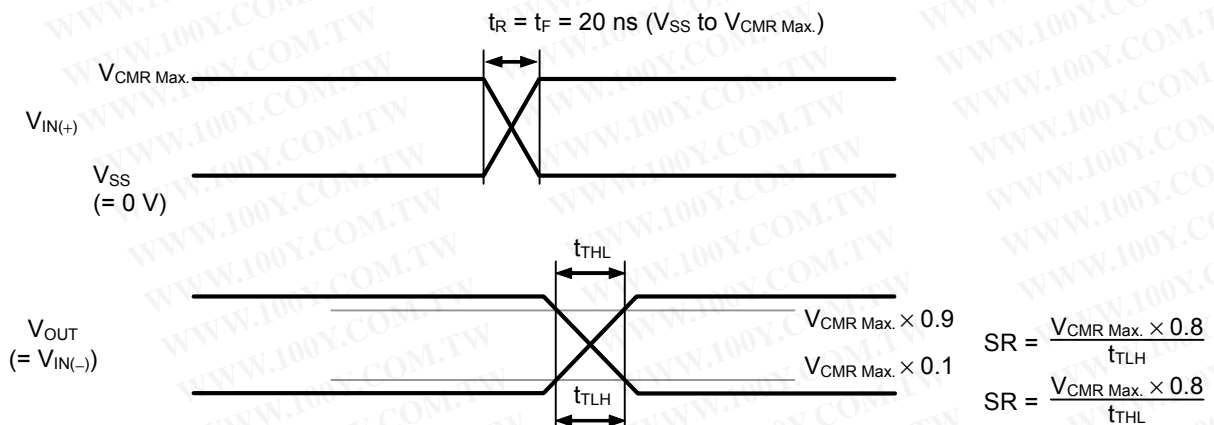

Figure 16

■ **Precautions**

- Generally an operational amplifier may cause oscillation, depending on the selection of external parts. Perform thorough evaluation using the actual application to set the constant.
- Do not apply an electrostatic discharge to this IC that exceeds performance ratings of the built-in electrostatic protection circuit.
- SII Semiconductor Corporation claims no responsibility for any disputes arising out of or in connection with any infringement by products including this IC of patents owned by a third party.

■ **Characteristics (Typical Data)**

**1. Current consumption (per circuit) vs. Power supply voltage**

**1.1 S-89110 Series**

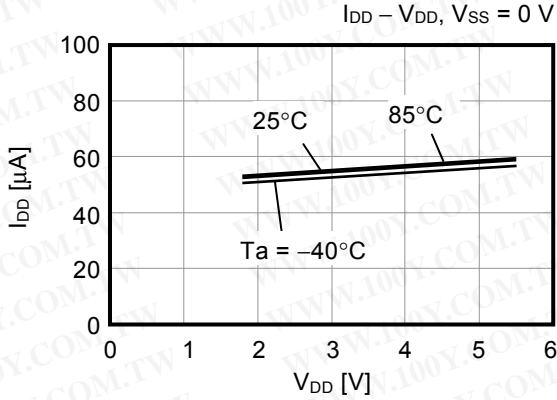

**1.2 S-89120 Series**

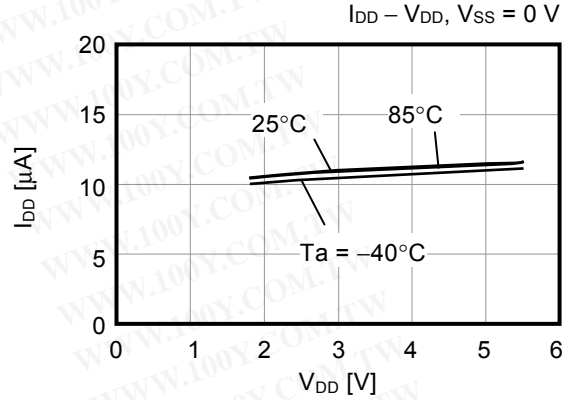

**2. Voltage gain vs. Frequency**

**2.1 S-89110 Series**

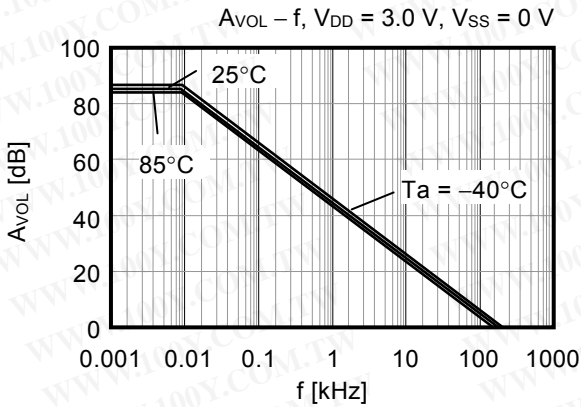

**2.2 S-89120 Series**

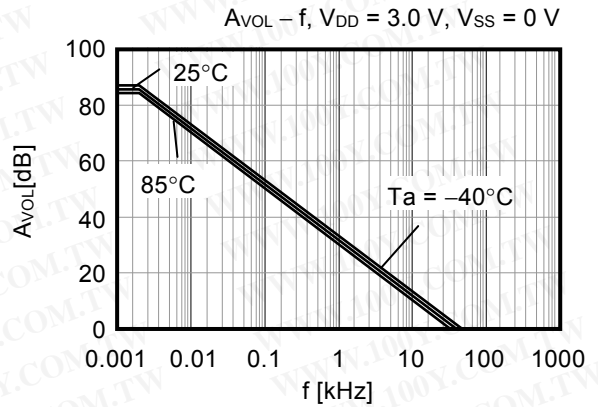

**3. Output current**

**3.1  $I_{SOURCE}$  vs. Power supply voltage**

**3.1.1 S-89110 Series**

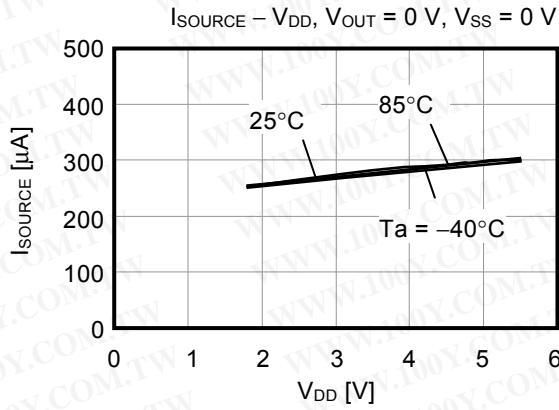

**3.1.2 S-89120 Series**

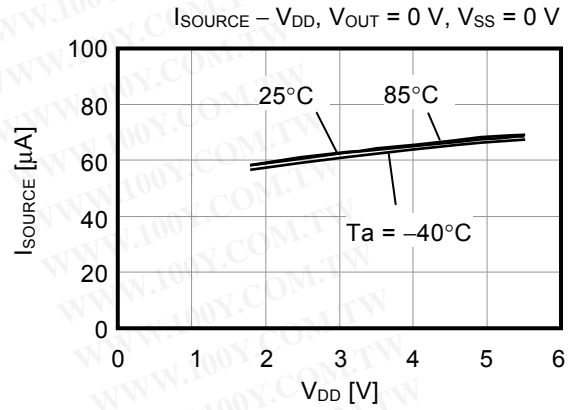

**3.2  $I_{SINK}$  vs. Power supply voltage**

**3.2.1 S-89110 Series**

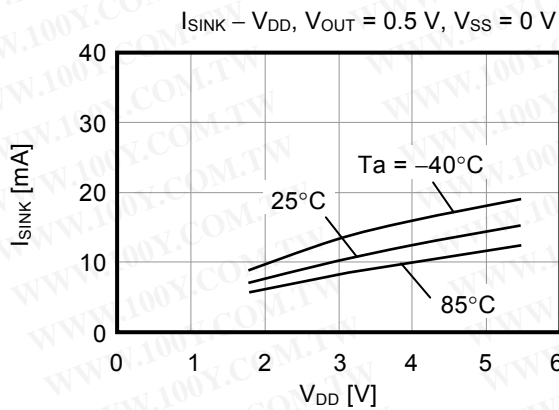

**3.2.2 S-89120 Series**

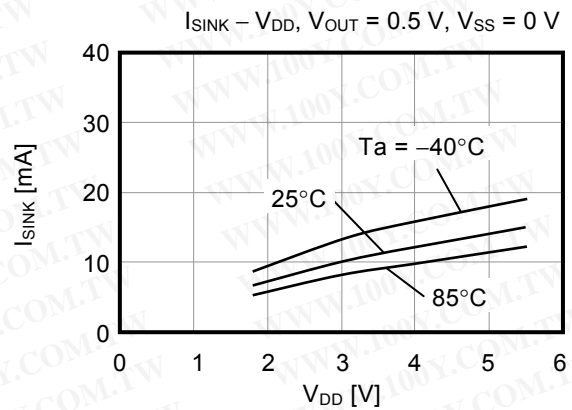



**3.3 Output voltage (V<sub>OUT</sub>) vs. I<sub>SOURCE</sub>**

**3.3.1 S-89110 Series**

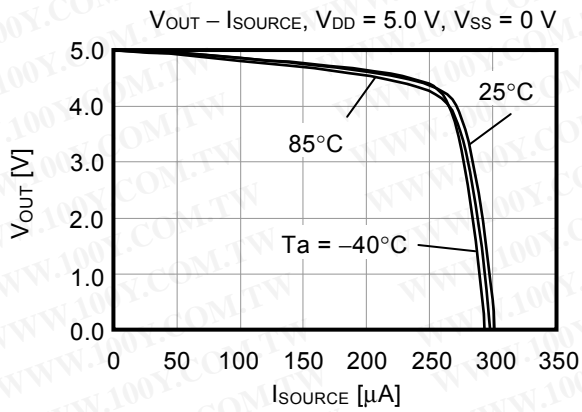
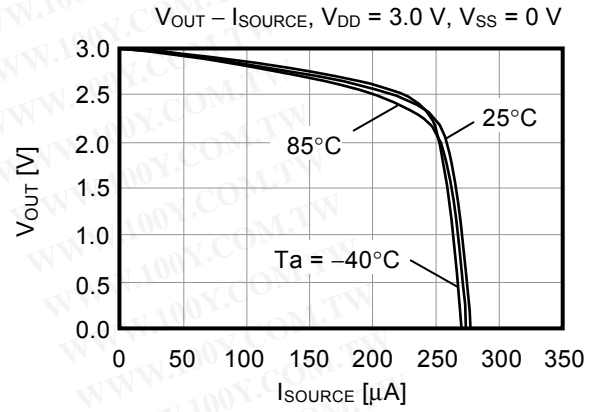
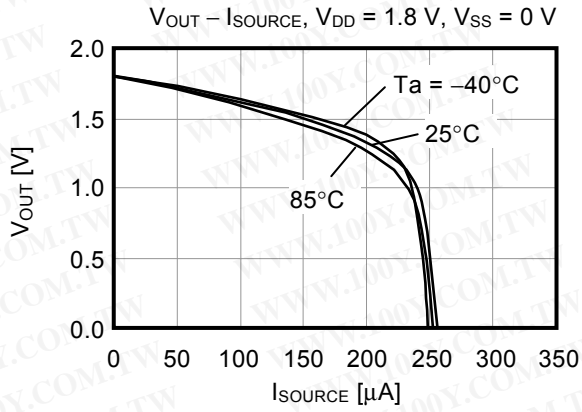

**3.3.2 S-89120 Series**

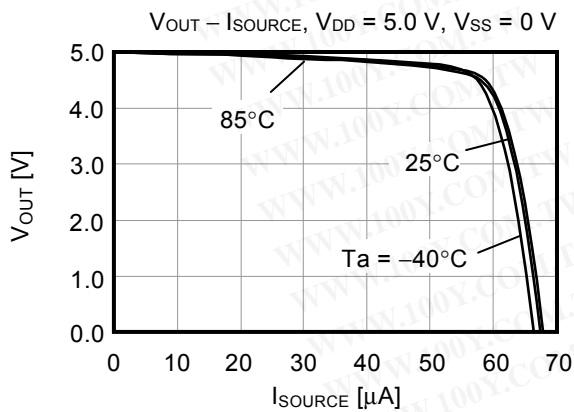
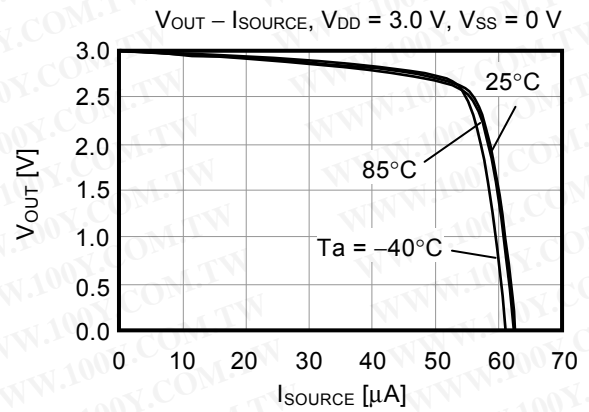
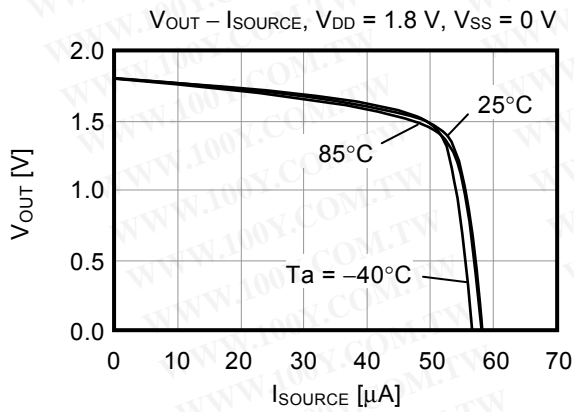

**3.4 Output voltage ( $V_{OUT}$ ) vs.  $I_{SINK}$**

**3.4.1 S-89110 Series**

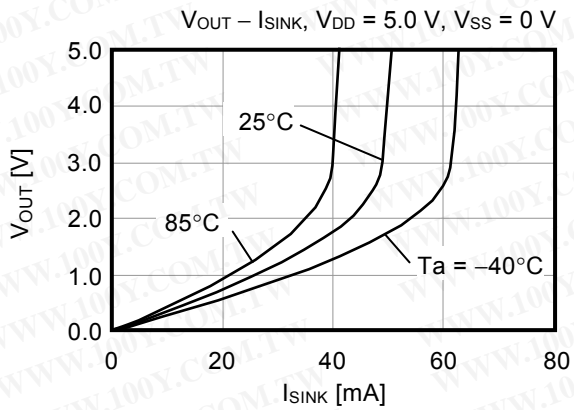
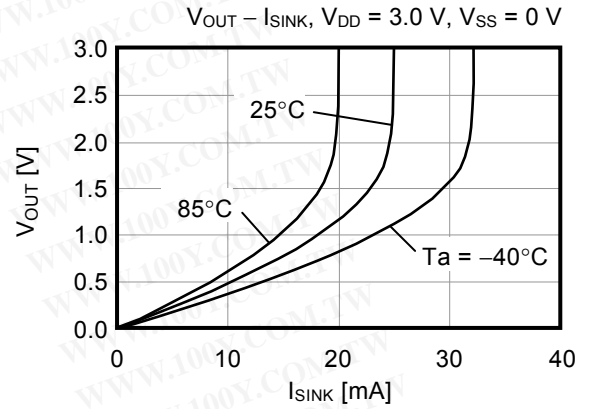
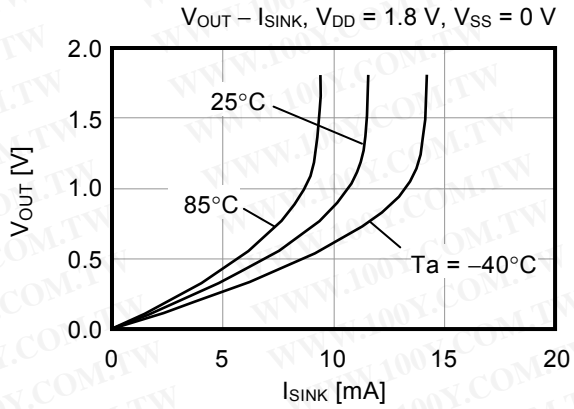

**3.4.2 S-89120 Series**

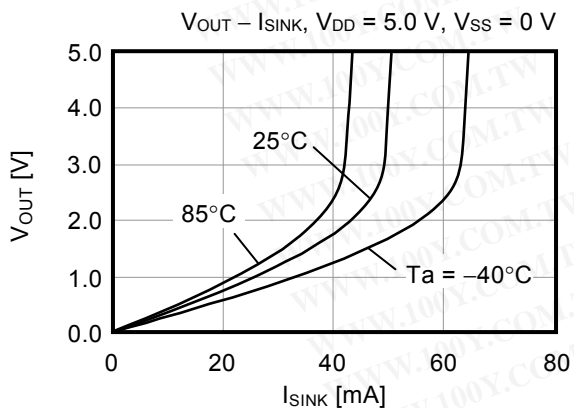
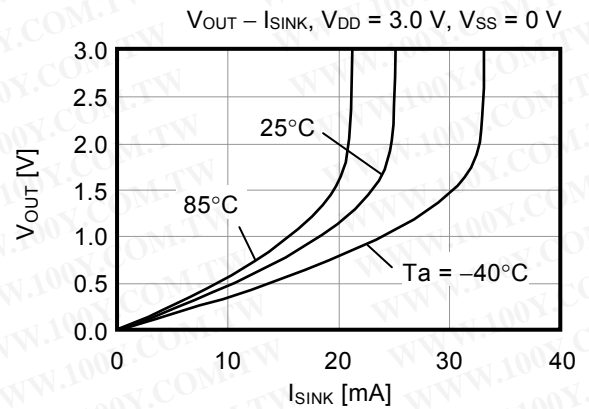
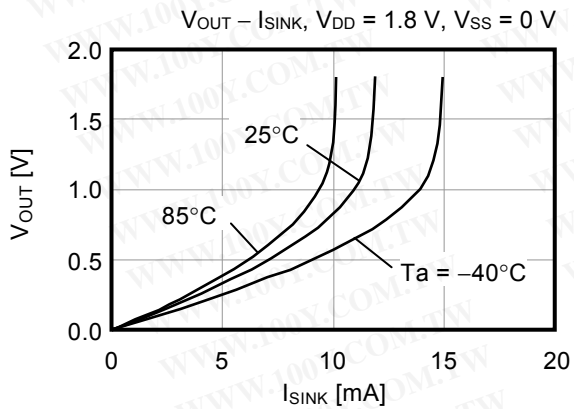

**■ Marking Specifications**

**1. SC-88A**

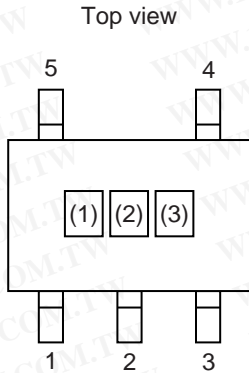

(1) to (3): Product Code (refer to **Product Name vs. Product Code**)

**Product Name vs. Product Code**

Product Name	Product Code		
	(1)	(2)	(3)
S-89110ANC-1A1-TFz	1	A	1
S-89120ANC-1A2-TFz	1	A	2

**Remark** z: G or S

**2. SOT-23-5**

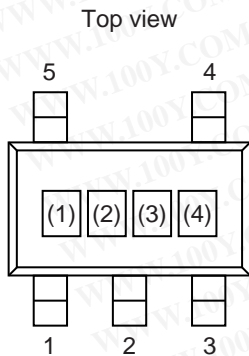

(1) to (3): Product Code (refer to **Product Name vs. Product Code**)  
 (4): Lot number

**Product Name vs. Product Code**

Product Name	Product Code		
	(1)	(2)	(3)
S-89110AMC-1A1-TFU	1	A	1
S-89120AMC-1A2-TFU	1	A	2

**3. SNT-8A**

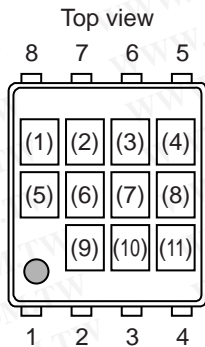

- (1): Blank
- (2) to (4): Product Code (refer to **Product Name vs. Product Code**)
- (5), (6): Blank
- (7) to (11): Lot number

**Product Name vs. Product Code**

Product Name	Product Code		
	(2)	(3)	(4)
S-89110BPH-H4A-TFU	H	4	A
S-89120BPH-H4B-TFU	H	4	B

**4. TMSOP-8**

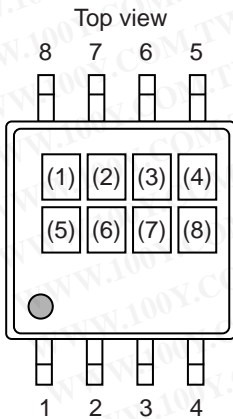

- (1): Blank
- (2) to (4): Product Code (refer to **Product Name vs. Product Code**)
- (5): Blank
- (6) to (8): Lot number

**Product Name vs. Product Code**

Product Name	Product Code		
	(2)	(3)	(4)
S-89110BFM-H4A-TFU	H	4	A
S-89120BFM-H4B-TFU	H	4	B

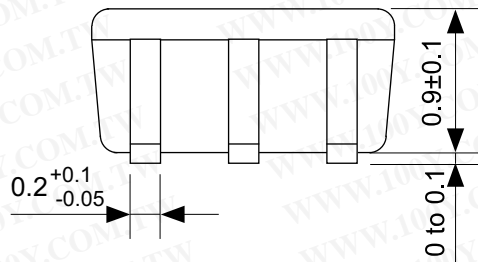
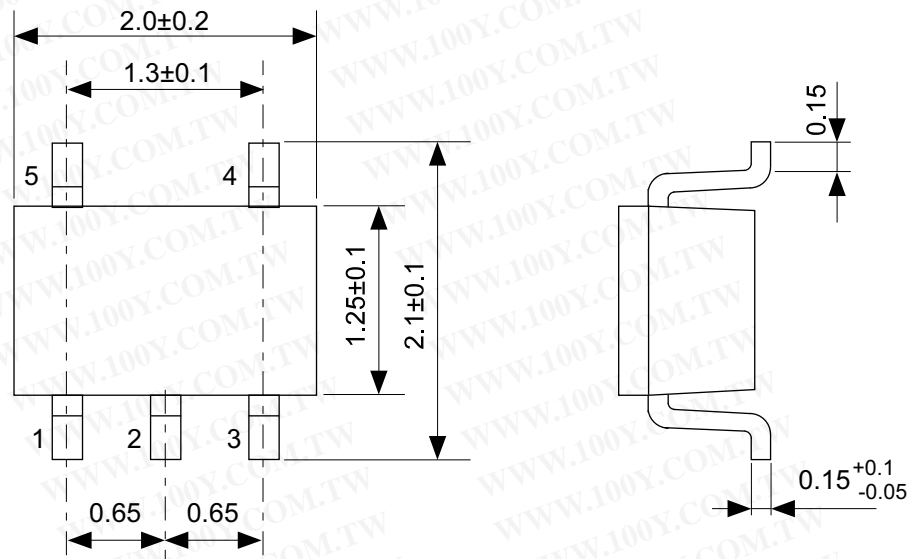

No. NP005-B-P-SD-1.1

TITLE	SC88A-B-PKG Dimensions
No.	NP005-B-P-SD-1.1
SCALE	
UNIT	mm
SII Semiconductor Corporation	

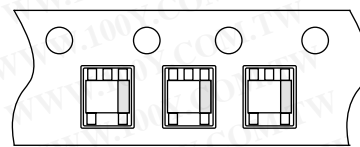
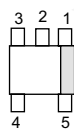
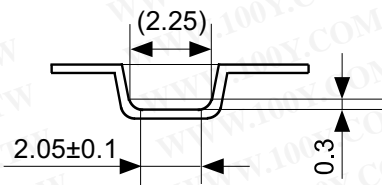
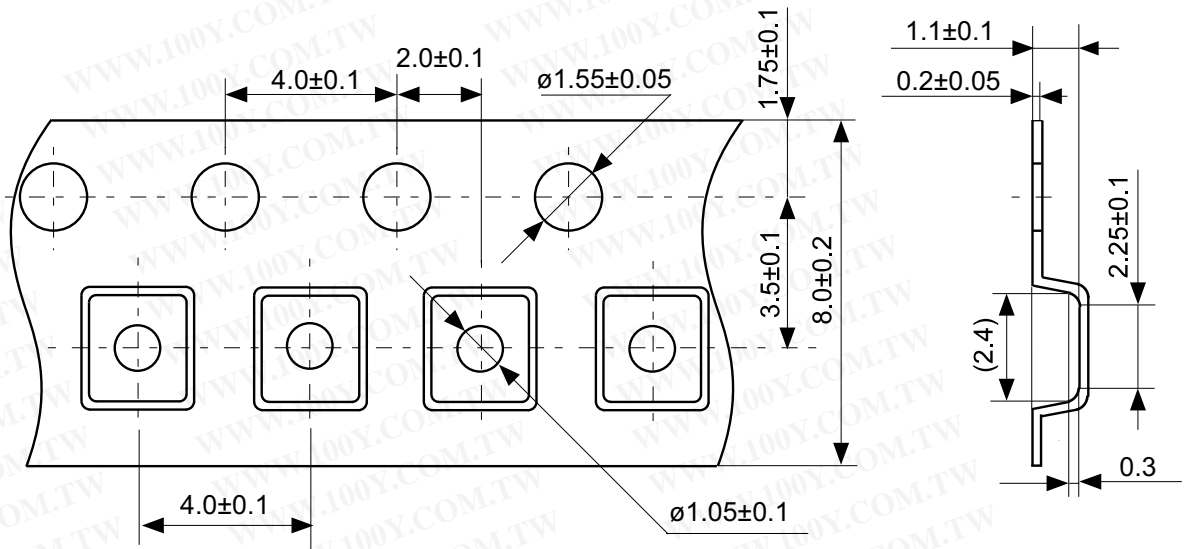

→  
Feed direction

**No. NP005-B-C-SD-2.0**

TITLE	SC88A-B-Carrier Tape
No.	NP005-B-C-SD-2.0
SCALE	
UNIT	mm
SII Semiconductor Corporation	

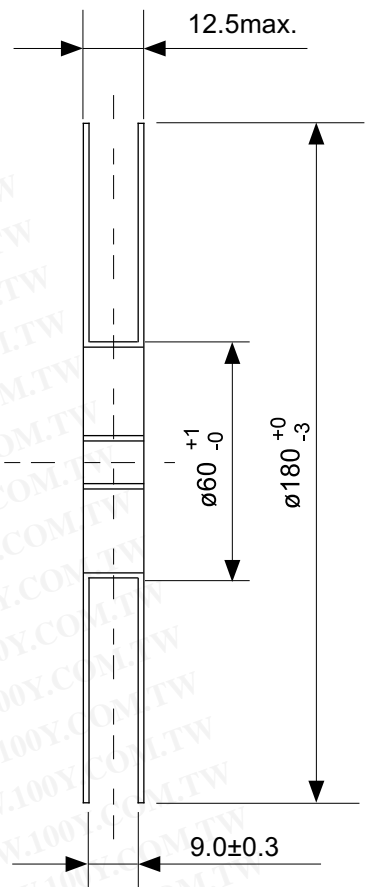
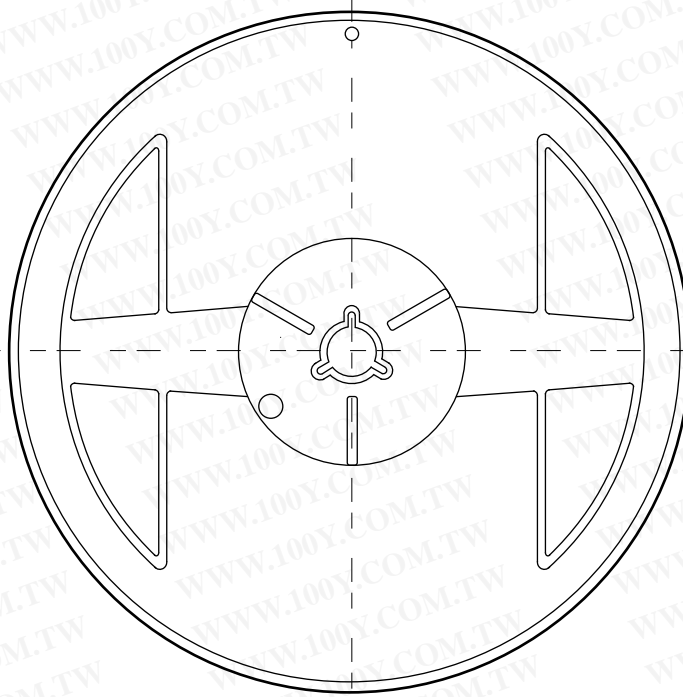

Enlarged drawing in the central part

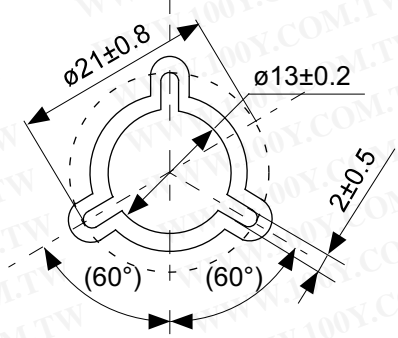

No. NP005-B-R-SD-2.1

TITLE	SC88A-B-Reel		
No.	NP005-B-R-SD-2.1		
SCALE		QTY.	3000
UNIT	mm		
SII Semiconductor Corporation			

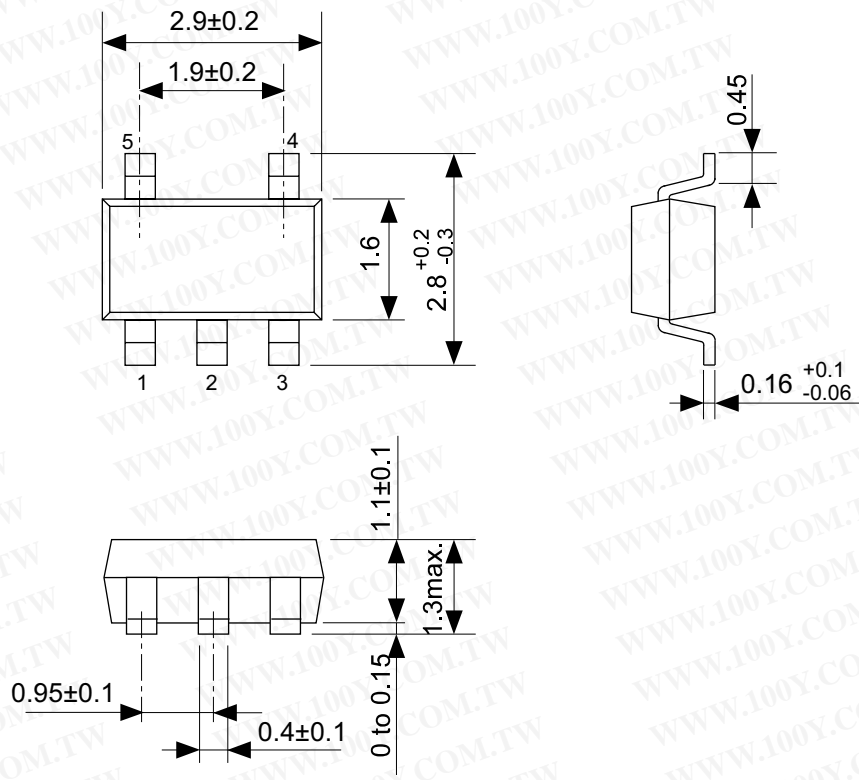

No. MP005-A-P-SD-1.2

TITLE	SOT235-A-PKG Dimensions
No.	MP005-A-P-SD-1.2
SCALE	
UNIT	mm
SII Semiconductor Corporation	



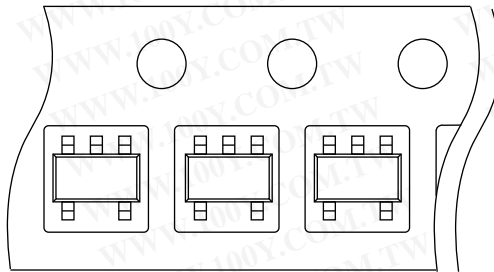
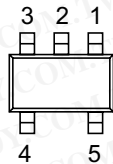
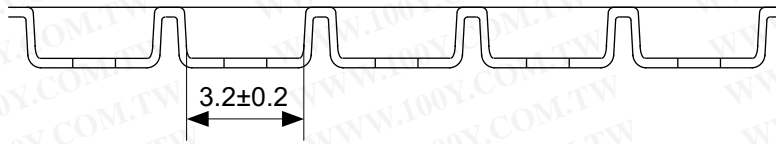
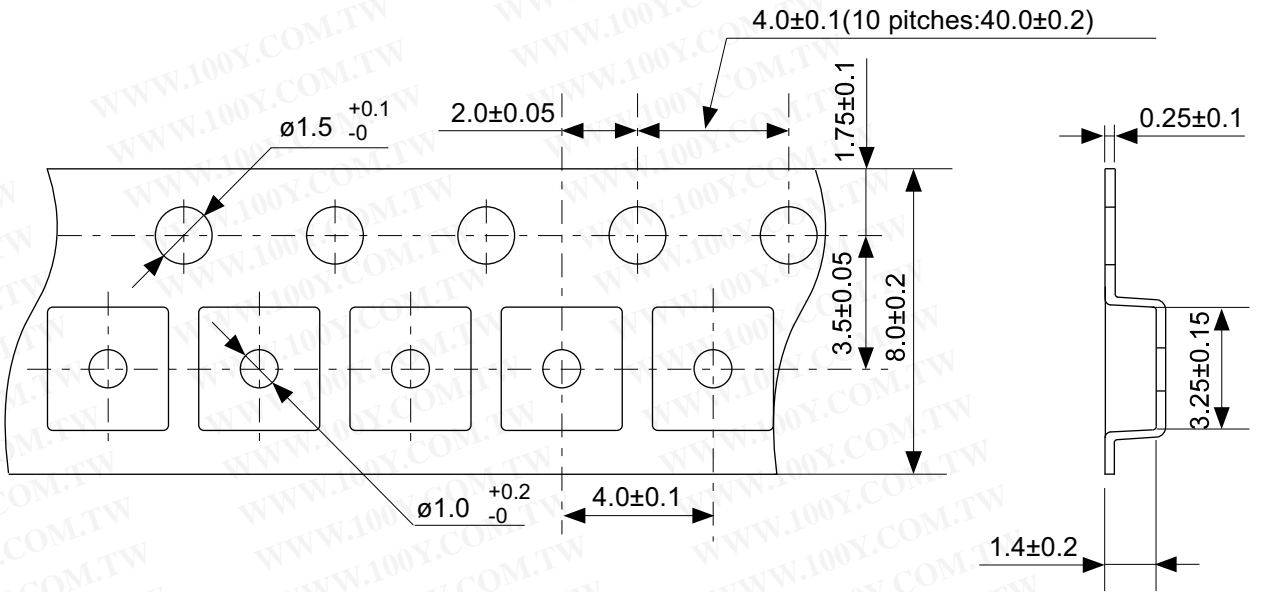

→  
Feed direction

No. MP005-A-C-SD-2.1

TITLE	SOT235-A-Carrier Tape
No.	MP005-A-C-SD-2.1
SCALE	
UNIT	mm
SII Semiconductor Corporation	

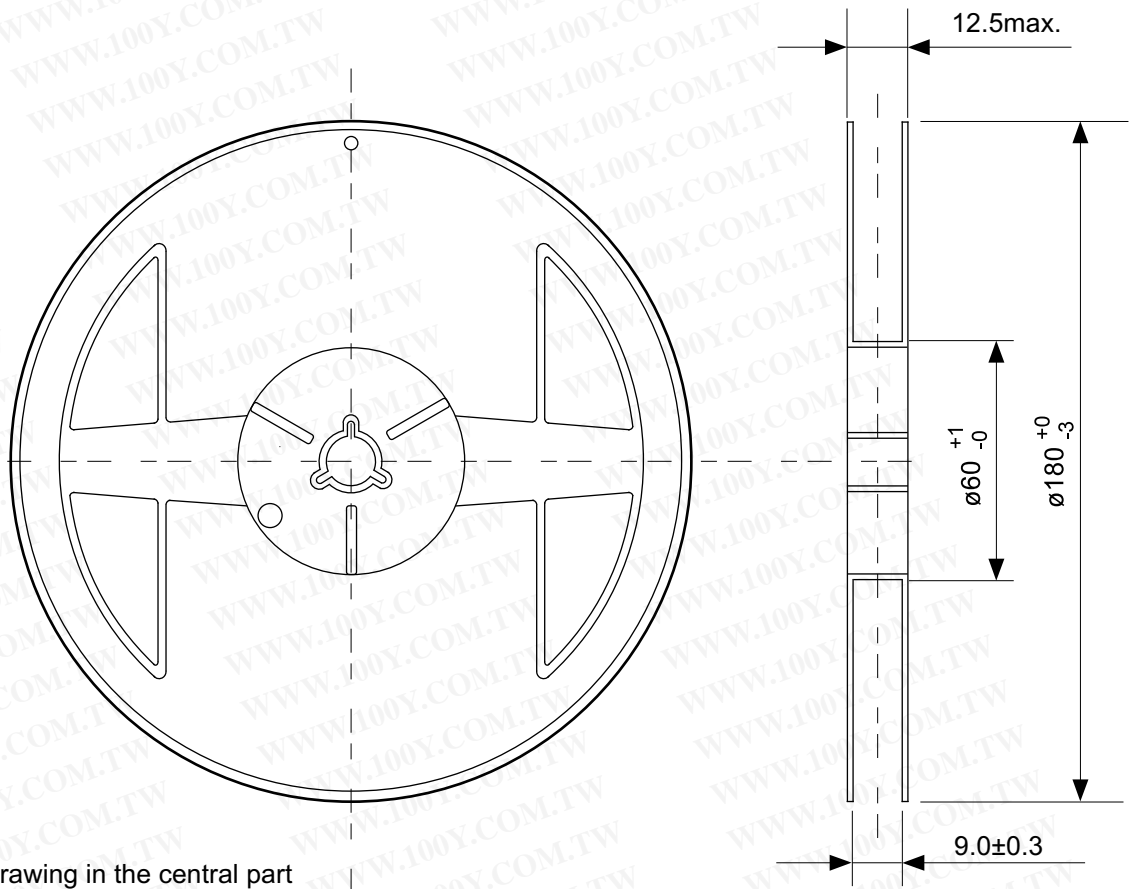

Enlarged drawing in the central part

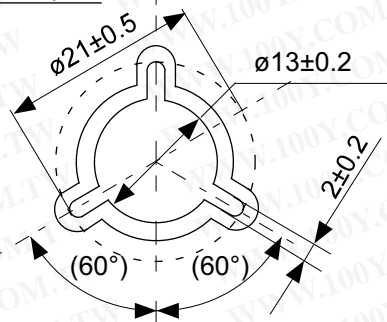

No. MP005-A-R-SD-1.1

TITLE	SOT235-A-Reel		
No.	MP005-A-R-SD-1.1		
SCALE		QTY.	3,000
UNIT	mm		
SII Semiconductor Corporation			

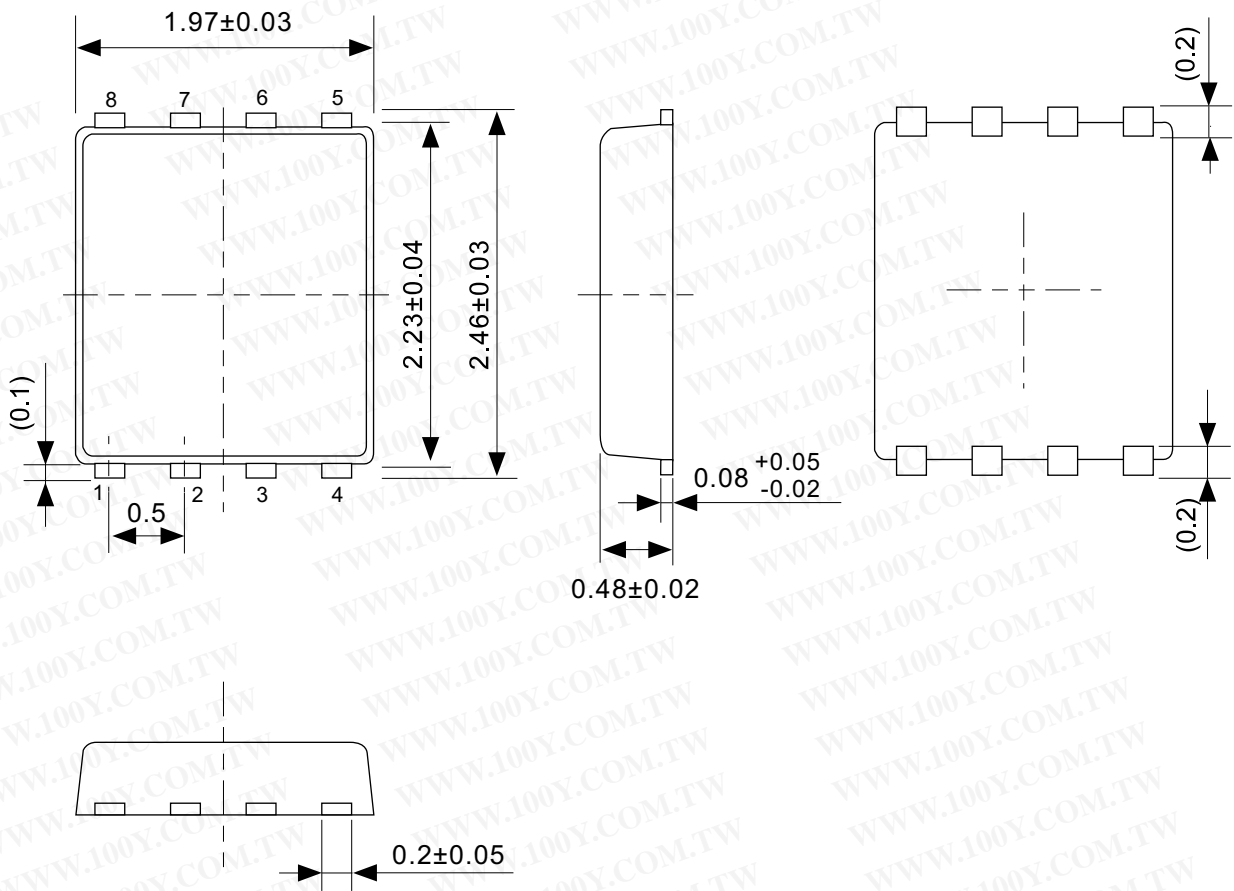

No. PH008-A-P-SD-2.0

TITLE	SNT-8A-A-PKG Dimensions
No.	PH008-A-P-SD-2.0
SCALE	
UNIT	mm
SII Semiconductor Corporation	

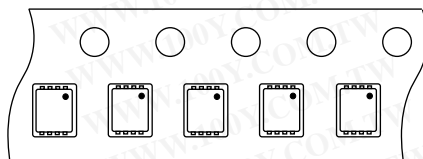
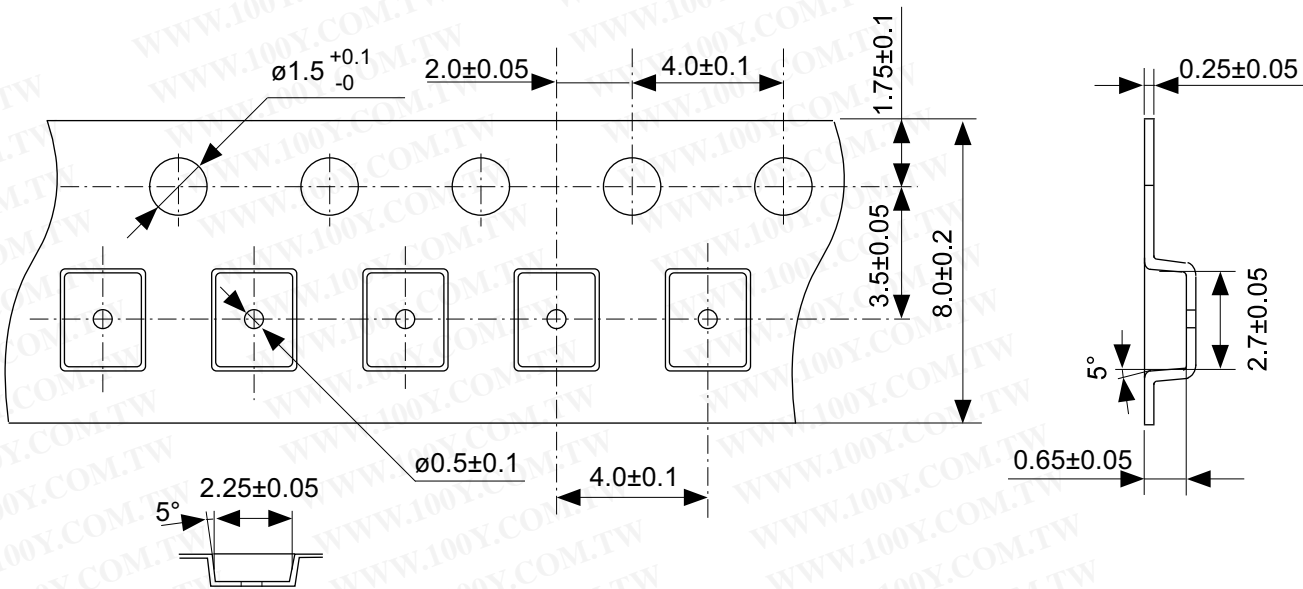

Feed direction

No. PH008-A-C-SD-1.0

TITLE	SNT-8A-A-Carrier Tape
No.	PH008-A-C-SD-1.0
SCALE	
UNIT	mm
SII Semiconductor Corporation	

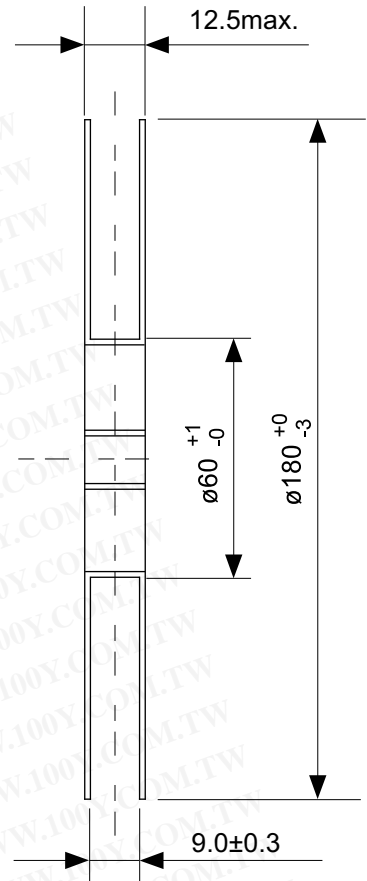
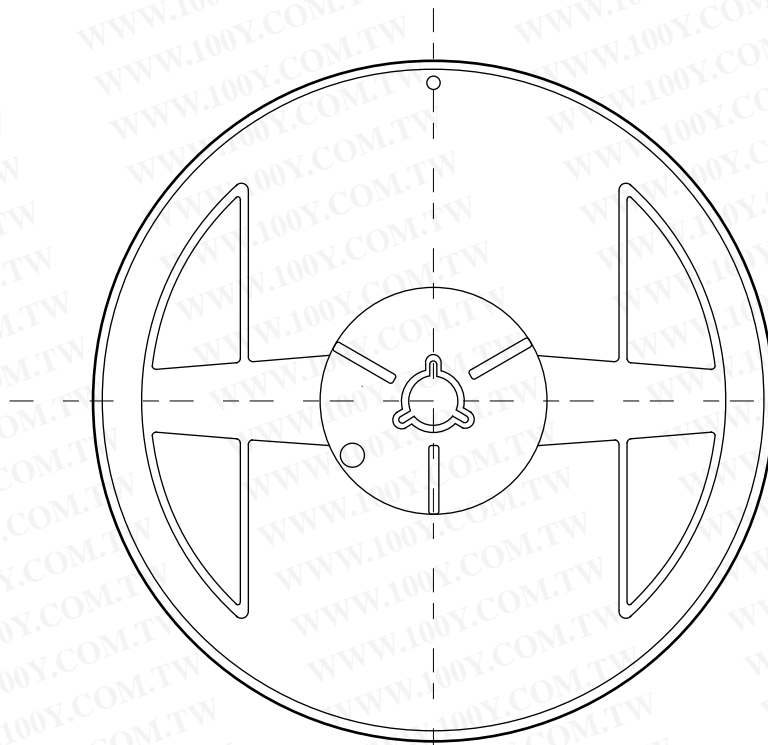

Enlarged drawing in the central part

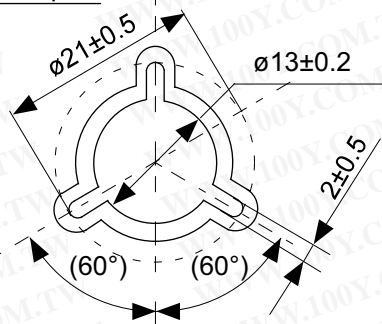

No. PH008-A-R-SD-1.0

TITLE	SNT-8A-A-Reel		
No.	PH008-A-R-SD-1.0		
SCALE		QTY.	5,000
UNIT	mm		
SII Semiconductor Corporation			

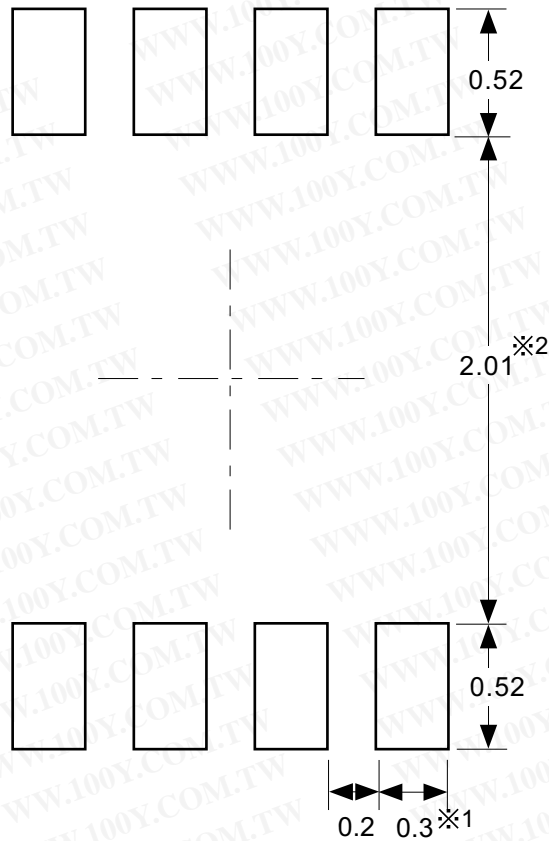

※1. ランドパターンの幅に注意してください (0.25 mm min. / 0.30 mm typ.).  
 ※2. パッケージ中央にランドパターンを広げないでください (1.96 mm ~ 2.06 mm).

- 注意**
1. パッケージのモールド樹脂下にシルク印刷やハンダ印刷などしないでください。
  2. パッケージ下の配線上のソルダーレジストなどの厚みをランドパターン表面から0.03 mm以下にしてください。
  3. マスク開口サイズと開口位置はランドパターンと合わせてください。
  4. 詳細は“SNTパッケージ活用の手引き”を参照してください。

※1. Pay attention to the land pattern width (0.25 mm min. / 0.30 mm typ.).  
 ※2. Do not widen the land pattern to the center of the package (1.96 mm to 2.06mm).

- Caution**
1. Do not do silkscreen printing and solder printing under the mold resin of the package.
  2. The thickness of the solder resist on the wire pattern under the package should be 0.03 mm or less from the land pattern surface.
  3. Match the mask aperture size and aperture position with the land pattern.
  4. Refer to "SNT Package User's Guide" for details.

※1. 请注意焊盘模式的宽度 (0.25 mm min. / 0.30 mm typ.).  
 ※2. 请勿向封装中间扩展焊盘模式 (1.96 mm ~ 2.06 mm)。

- 注意**
1. 请勿在树脂型封装的下面印刷丝网、焊锡。
  2. 在封装下、布线上的阻焊膜厚度 (从焊盘模式表面起) 请控制在 0.03 mm 以下。
  3. 钢网的开口尺寸和开口位置请与焊盘模式对齐。
  4. 详细内容请参阅 "SNT 封装的应用指南"。

No. PH008-A-L-SD-4.1

TITLE	SNT-8A-A -Land Recommendation
No.	PH008-A-L-SD-4.1
SCALE	
UNIT	mm
SII Semiconductor Corporation	

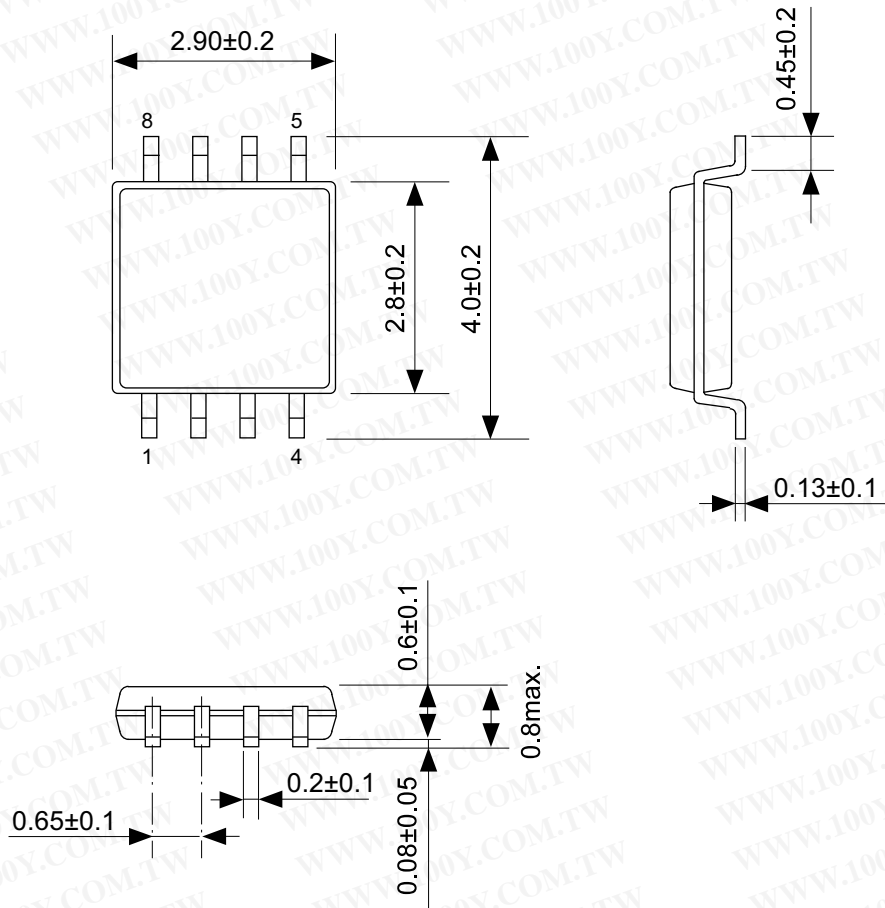

No. FM008-A-P-SD-1.1

TITLE	TMSOP8-A-PKG Dimensions
No.	FM008-A-P-SD-1.1
SCALE	
UNIT	mm

SII Semiconductor Corporation

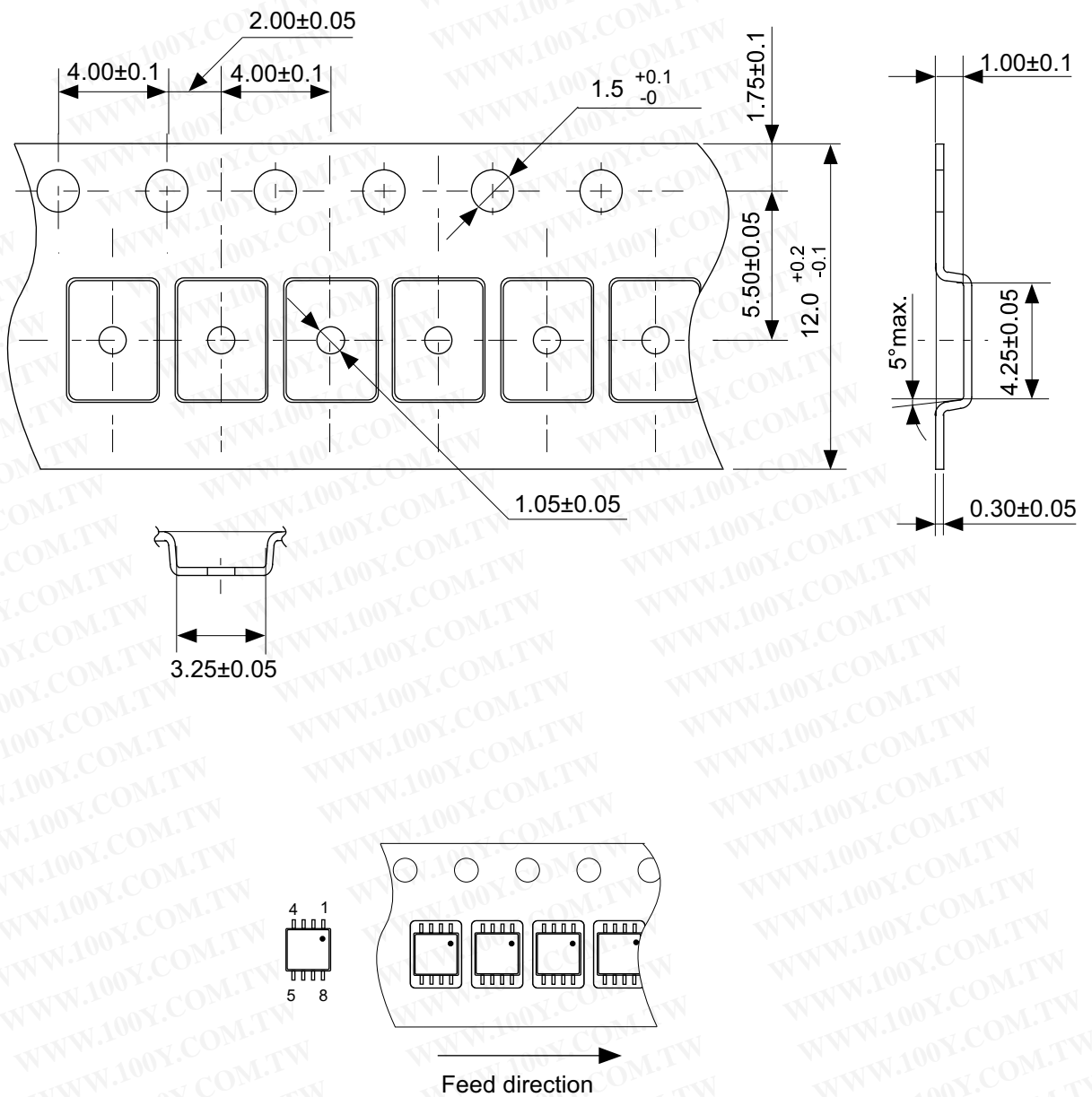

No. FM008-A-C-SD-2.0

TITLE	TMSOP8-A-Carrier Tape
No.	FM008-A-C-SD-2.0
SCALE	
UNIT	mm

SII Semiconductor Corporation



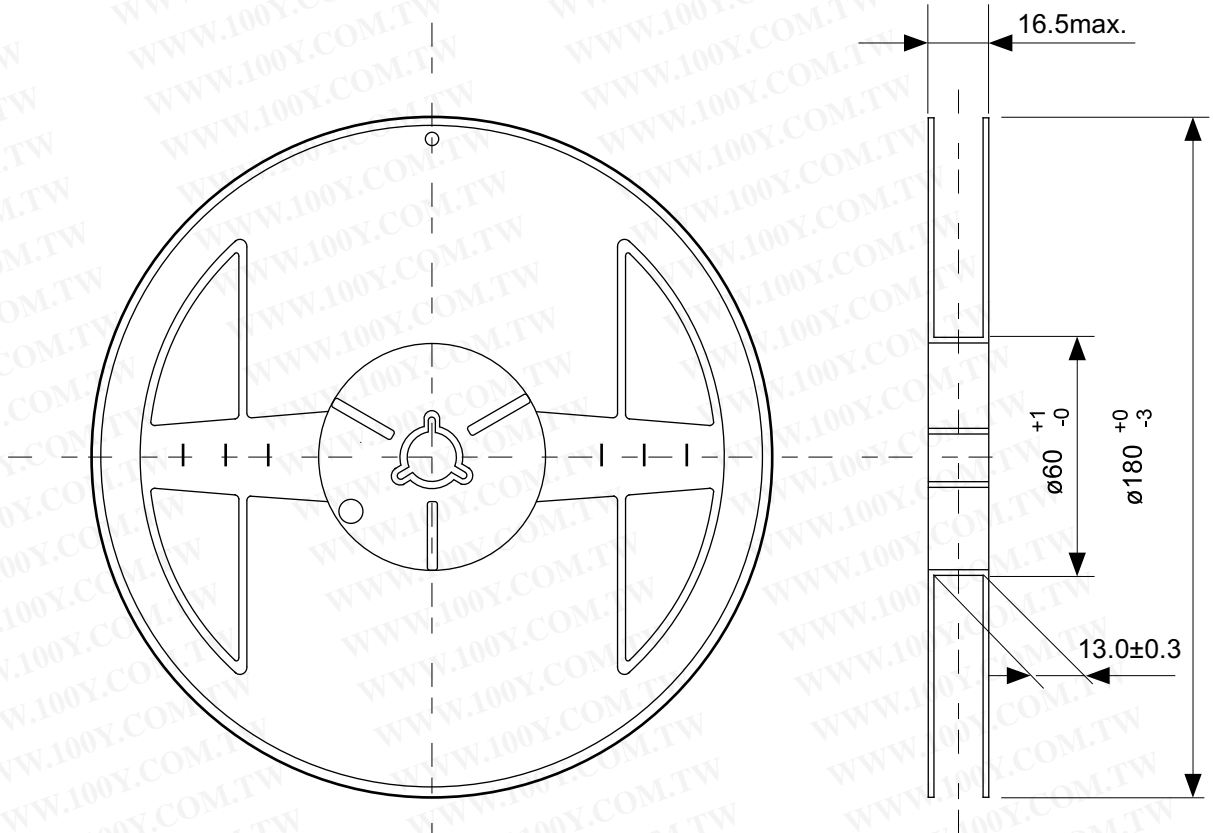

Enlarged drawing in the central part

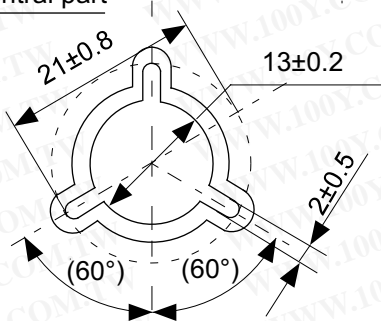

勝特力材料 886-3-5753170  
 勝特力电子(上海) 86-21-34970699  
 勝特力电子(深圳) 86-755-83298787  
[Http://www.100y.com.tw](http://www.100y.com.tw)

No. FM008-A-R-SD-1.0

TITLE	TMSOP8-A-Reel		
No.	FM008-A-R-SD-1.0		
SCALE		QTY.	4,000
UNIT	mm		
SII Semiconductor Corporation			