



勝特力材料 886-3-5753170
勝特力电子(上海) 86-21-34970699
勝特力电子(深圳) 86-755-83298787
[Http://www.100y.com.tw](http://www.100y.com.tw)

LM139, LM239, LM339

Low-power quad voltage comparators

Features

- Wide single supply voltage range or dual supplies for all devices: +2 to +36 V or ± 1 V to ± 18 V
- Very low supply current (1.1 mA) independent of supply voltage
- Low input bias current: 25 nA typ
- Low input offset current: ± 5 nA typ
- Low input offset voltage: ± 1 mV typ
- Input common-mode voltage range includes ground
- Low output saturation voltage: 250 mV typ; ($I_{SINK} = 4$ mA)
- Differential input voltage range equal to the supply voltage
- TTL, DTL, ECL, MOS, CMOS compatible outputs

Description

This family of devices consists of four independent precision-voltage comparators with an offset voltage specification as low as 2 mV maximum for LM339A, LM239A and LM139A. Each comparator has been designed specifically to operate from a single power supply over a wide range of voltages. Operation from split power supplies is also possible.

These comparators also have a unique characteristic in that the input common mode voltage range includes ground even though operated from a single power supply voltage.

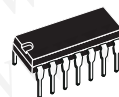

N
DIP14
(Plastic package)

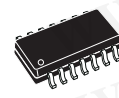

D
SO-14
(Plastic micropackage)

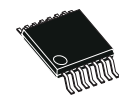

P
TSSOP14
(Thin shrink small outline package)



Q
QFN16 3x3
(Plastic micropackage)

1 Pin and schematic diagram

勝特力材料 886-3-5753170
 勝特力电子(上海) 86-21-34970699
 勝特力电子(深圳) 86-755-83298787
[Http://www.100y.com.tw](http://www.100y.com.tw)

Figure 1. Pin connections (top view)

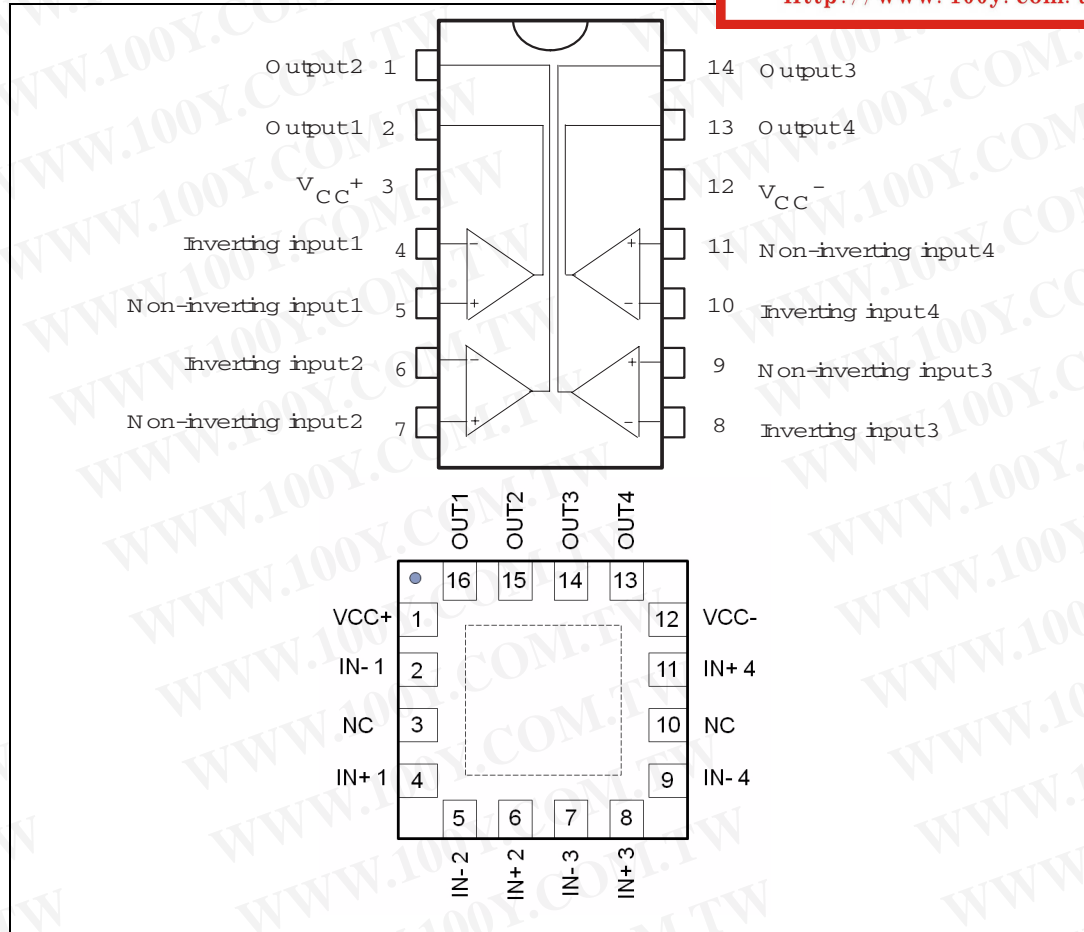
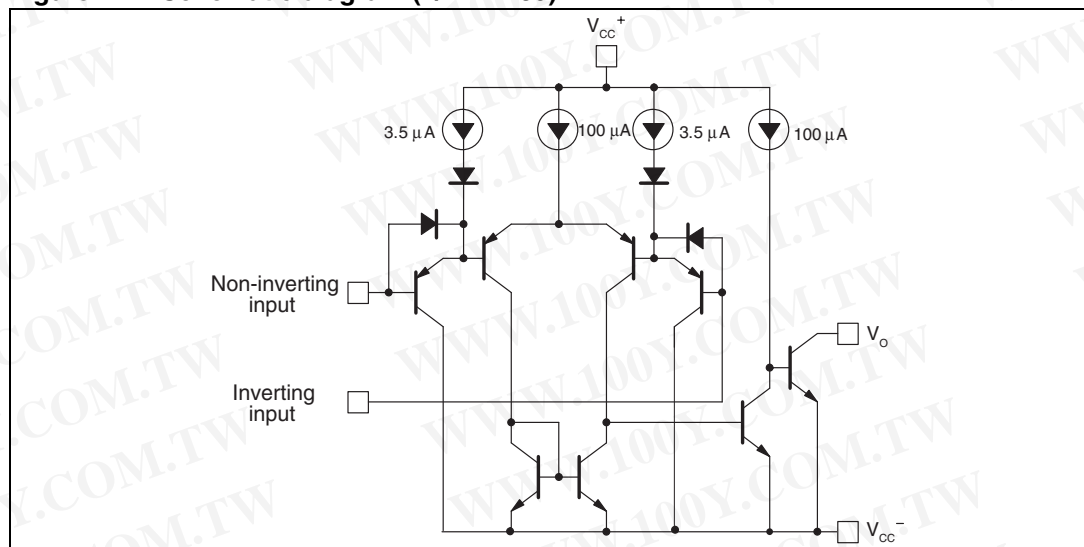

Figure 2. Schematic diagram (1/4 LM139)



2 Absolute maximum ratings and operating conditions

Table 1. Absolute maximum ratings

Symbol	Parameter	Value	Unit
V_{CC}	Supply voltage	± 18 or 36	V
V_{ID}	Differential input voltage	± 36	V
V_{IN}	Input voltage	-0.3 to +36	V
	Output short-circuit to ground ⁽¹⁾	Infinite	
R_{thja}	Thermal resistance junction to ambient ⁽²⁾		°C/W
	DIP14	80	
	SO-14	105	
	TSSOP14 QFN16 3x3	100 45	
R_{thjc}	Thermal resistance junction to case ⁽²⁾		°C/W
	DIP14	33	
	SO-14	31	
	TSSOP14 QFN16 3x3	32 14	
T_{stg}	Storage temperature range	-65 to +150	°C
T_j	Junction temperature	+150	°C
T_{LEAD}	Lead temperature (soldering 10 seconds)	260	°C
ESD	Human body model (HBM) ⁽³⁾	500	V
	Machine model (MM) ⁽⁴⁾	100	
	Charged device model (CDM) ⁽⁵⁾	1500	

- Short-circuits from the output to V_{CC}^+ can cause excessive heating and eventual destruction. The maximum output current is approximately 20 mA independent of the magnitude of V_{CC}^+ .
- Short-circuits can cause excessive heating. These values are typical.
- Human body model: a 100 pF capacitor is charged to the specified voltage, then discharged through a 1.5 k Ω resistor between two pins of the device. This is done for all couples of connected pin combinations while the other pins are floating.
- Machine model: a 200 pF capacitor is charged to the specified voltage, then discharged directly between two pins of the device with no external series resistor (internal resistor < 5 Ω). This is done for all couples of connected pin combinations while the other pins are floating.
- Charged device model: all pins and the package are charged together to the specified voltage and then discharged directly to the ground through only one pin. This is done for all pins.

勝特力材料 886-3-5753170
 勝特力电子(上海) 86-21-34970699
 勝特力电子(深圳) 86-755-83298787
[Http://www.100y.com.tw](http://www.100y.com.tw)

Table 2. Operating conditions ($T_{amb} = 25^{\circ}C$)

Symbol	Parameter	Value	Unit
V_{CC}	Supply voltage	2 to 32 ± 1 to ± 16	V
V_{ICM}	Common mode input voltage range	0 to ($V_{CC}^{+} - 1.5$)	V
T_{oper}	Operating free-air temperature range – LM139, LM139A – LM239, LM239A – LM339, LM339A	-55, +125 -40, +105 0, +70	$^{\circ}C$

勝特力材料 886-3-5753170
 勝特力电子(上海) 86-21-34970699
 勝特力电子(深圳) 86-755-83298787
[Http://www.100y.com.tw](http://www.100y.com.tw)

3 Electrical characteristics

Table 3. Electrical characteristics at $V_{CC}^+ = +5\text{ V}$, $V_{CC}^- = \text{GND}$, $T_{\text{amb}} = +25^\circ\text{ C}$ (unless otherwise specified)

Symbol	Parameter	LM139A - LM239A LM339A			LM139 - LM239 LM339			Unit
		Min.	Typ.	Max.	Min	Typ.	Max.	
V_{IO}	Input offset voltage ⁽¹⁾ $T_{\text{min}} \leq T_{\text{amb}} \leq T_{\text{max}}$		1	2 4		1	5 9	mV
I_{IO}	Input offset current $T_{\text{min}} \leq T_{\text{amb}} \leq T_{\text{max}}$		3	25 100		5	50 150	nA
I_{IB}	Input bias current (I^+ or I^-) ⁽²⁾ $T_{\text{min}} \leq T_{\text{amb}} \leq T_{\text{max}}$		25	100 300		25	250 400	nA
A_{VD}	Large signal voltage gain $V_{CC} = 15\text{ V}$, $R_L = 15\text{ k}\Omega$, $V_o = 1\text{ V to }11\text{ V}$	50	200		50	200		V/mV
I_{CC}	Supply current (all comparators) $V_{CC} = +5\text{ V}$, no load $V_{CC} = +30\text{ V}$, no load		1.1 1.3	2 2.5		1.1 1.3	2 2.5	mA
V_{ICM}	Input common mode voltage range ⁽³⁾ $V_{CC} = 30\text{ V}$ $T_{\text{min}} \leq T_{\text{amb}} \leq T_{\text{max}}$	0 0		$V_{CC}^+ - 1.5$ $V_{CC}^+ - 2$	0 0		$V_{CC}^+ - 1.5$ $V_{CC}^+ - 2$	V
V_{ID}	Differential input voltage ⁽⁴⁾			V_{CC}^+			V_{CC}^+	V
V_{OL}	Low level output voltage $V_{ID} = -1\text{ V}$, $I_{\text{SINK}} = 4\text{ mA}$ $T_{\text{min}} \leq T_{\text{amb}} \leq T_{\text{max}}$		250	400 700		250	400 700	mV
I_{OH}	High level output current $V_{CC} = V_o = 30\text{ V}$, $V_{ID} = 1\text{ V}$ $T_{\text{min}} \leq T_{\text{amb}} \leq T_{\text{max}}$		0.1	1		0.1	1	nA μA
I_{SINK}	Output sink current $V_{ID} = 1\text{ V}$, $V_o = 1.5\text{ V}$	6	16		6	16		mA
t_{re}	Response time ⁽⁵⁾ $R_L = 5.1\text{ k}\Omega$ connected to V_{CC}^+		1.3			1.3		μs

勝特力材料 886-3-5753170
 勝特力电子(上海) 86-21-34970699
 勝特力电子(深圳) 86-755-83298787
[Http://www.100y.com.tw](http://www.100y.com.tw)

Table 3. Electrical characteristics at $V_{CC^+} = +5\text{ V}$, $V_{CC^-} = \text{GND}$, $T_{\text{amb}} = +25^\circ\text{ C}$ (unless otherwise specified) (continued)

Symbol	Parameter	LM139A - LM239A LM339A			LM139 - LM239 LM339			Unit
		Min.	Typ.	Max.	Min.	Typ.	Max.	
trel	Large signal response time $R_L = 5.1\text{ k}\Omega$ connected to V_{CC^+} , $e_1 = \text{TTL}$, $V_{(\text{ref})} = +1.4\text{ V}$		300			300		ns

1. At output switch point, $V_o \approx 1.4\text{ V}$, V_{CC^+} from 5 V to 30 V, and over the full common-mode range (0 V to $V_{CC^+} - 1.5\text{ V}$).
2. The direction of the input current is out of the IC due to the PNP input stage. This current is essentially constant, independent of the state of the output, so no loading charge exists on the reference of input lines.
3. The input common-mode voltage of either input signal voltage should not be allowed to go negative by more than 0.3 V. The upper end of the common-mode voltage range is $V_{CC^+} - 1.5\text{ V}$, but either or both inputs can go to +30 V without damage.
4. Positive excursions of input voltage may exceed the power supply level. As long as the other voltage remains within the common-mode range, the comparator will provide a proper output state. The low input voltage state must not be less than -0.3 V (or 0.3 V below the negative power supply, if used).
5. The response time specified is for a 100 mV input step with 5 mV overdrive. For larger overdrive signals, 300 ns can be obtained.

勝特力材料 886-3-5753170
 勝特力电子(上海) 86-21-34970699
 勝特力电子(深圳) 86-755-83298787
[Http://www.100y.com.tw](http://www.100y.com.tw)

4 Electrical characteristics curves

Figure 3. Supply current vs. supply voltage

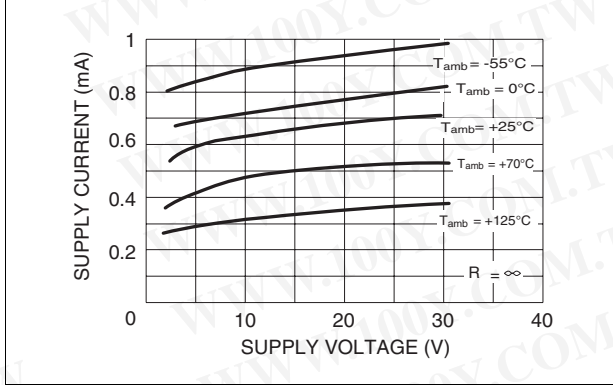

Figure 4. Input current vs. supply voltage

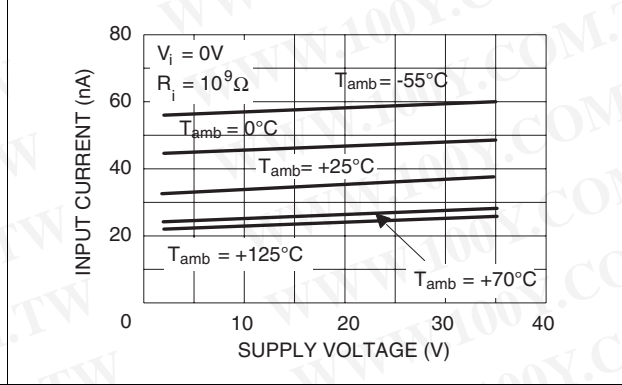

Figure 5. Output saturation voltage vs. output current

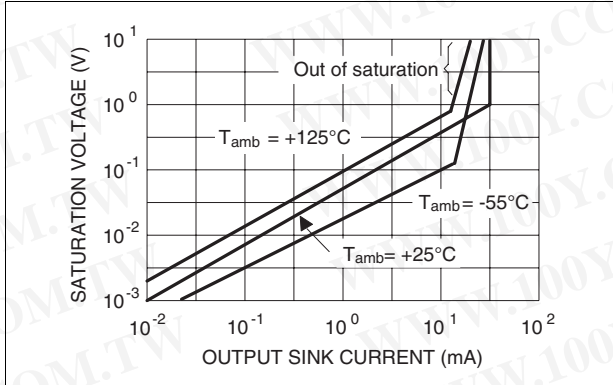

Figure 6. Response time for various input overdrives - negative transition

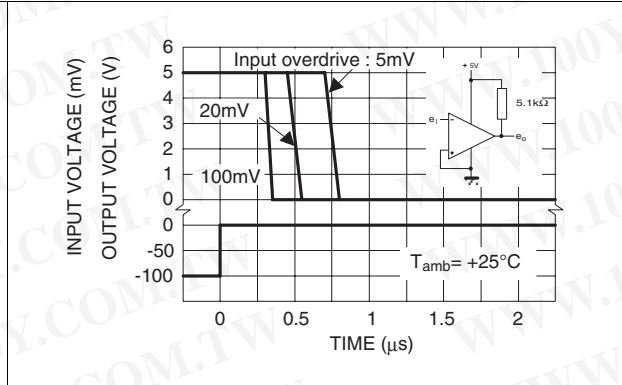
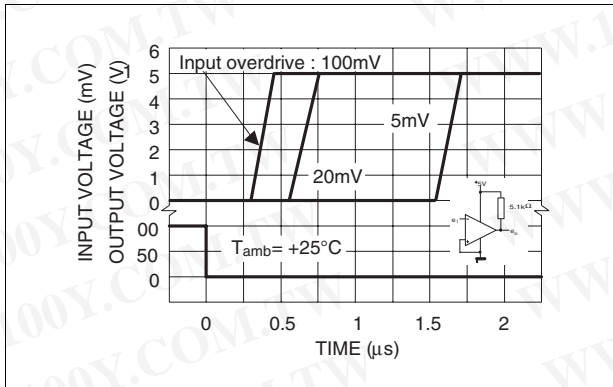

Figure 7. Response time for various input overdrives - positive transition



勝特力材料 886-3-5753170
 勝特力电子(上海) 86-21-34970699
 勝特力电子(深圳) 86-755-83298787
[Http://www.100y.com.tw](http://www.100y.com.tw)

5 Typical applications

Figure 8. Basic comparator

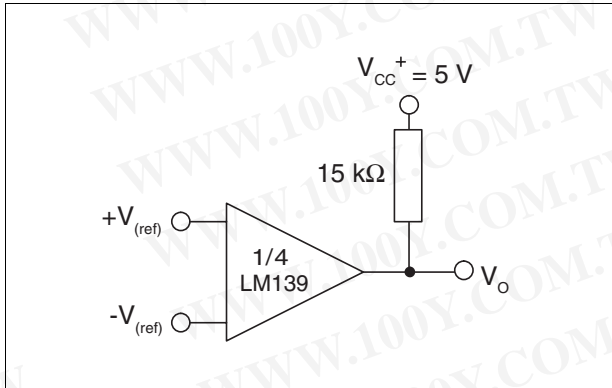

Figure 9. Driving CMOS

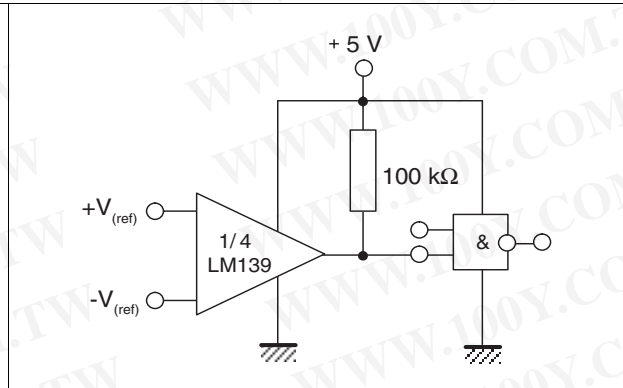

Figure 10. Driving TTL

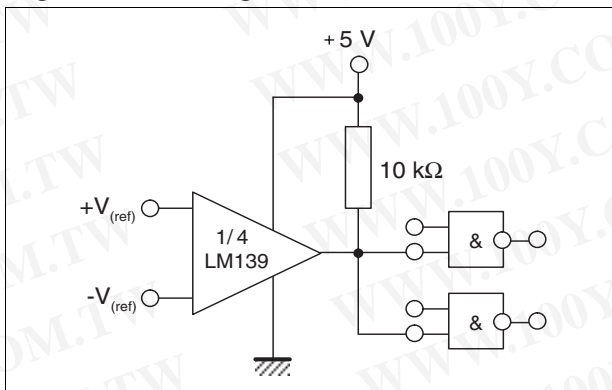

Figure 11. Low frequency op amp

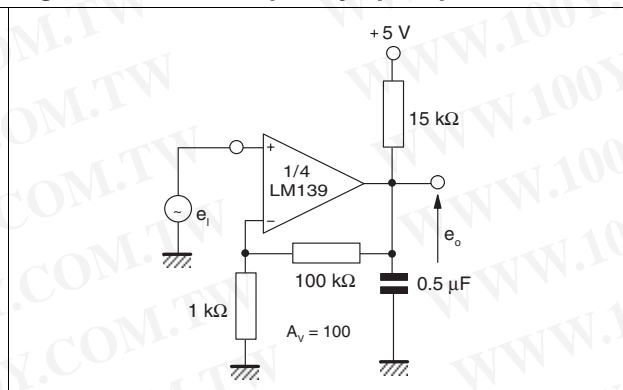

Figure 12. Low frequency op amp

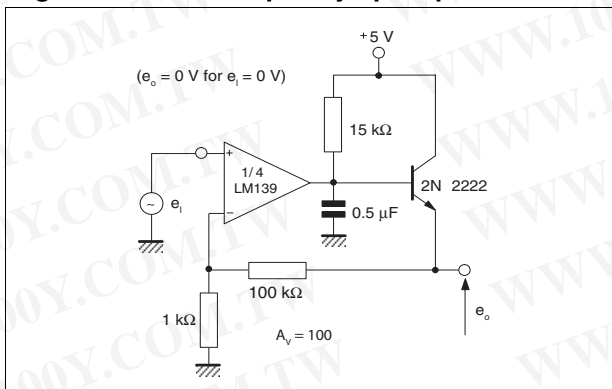
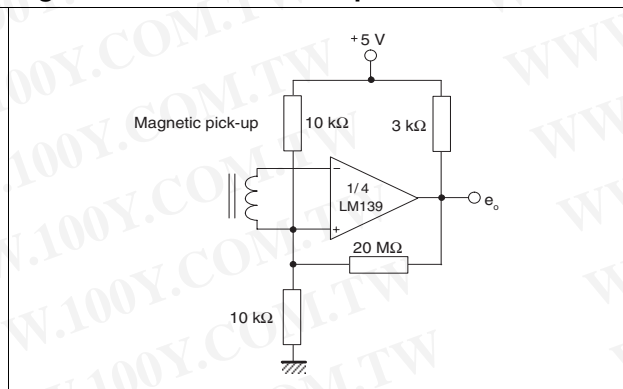

Figure 13. Transducer amplifier



勝特力材料 886-3-5753170
 勝特力电子(上海) 86-21-34970699
 勝特力电子(深圳) 86-755-83298787
[Http://www.100y.com.tw](http://www.100y.com.tw)

Figure 14. Time delay generator

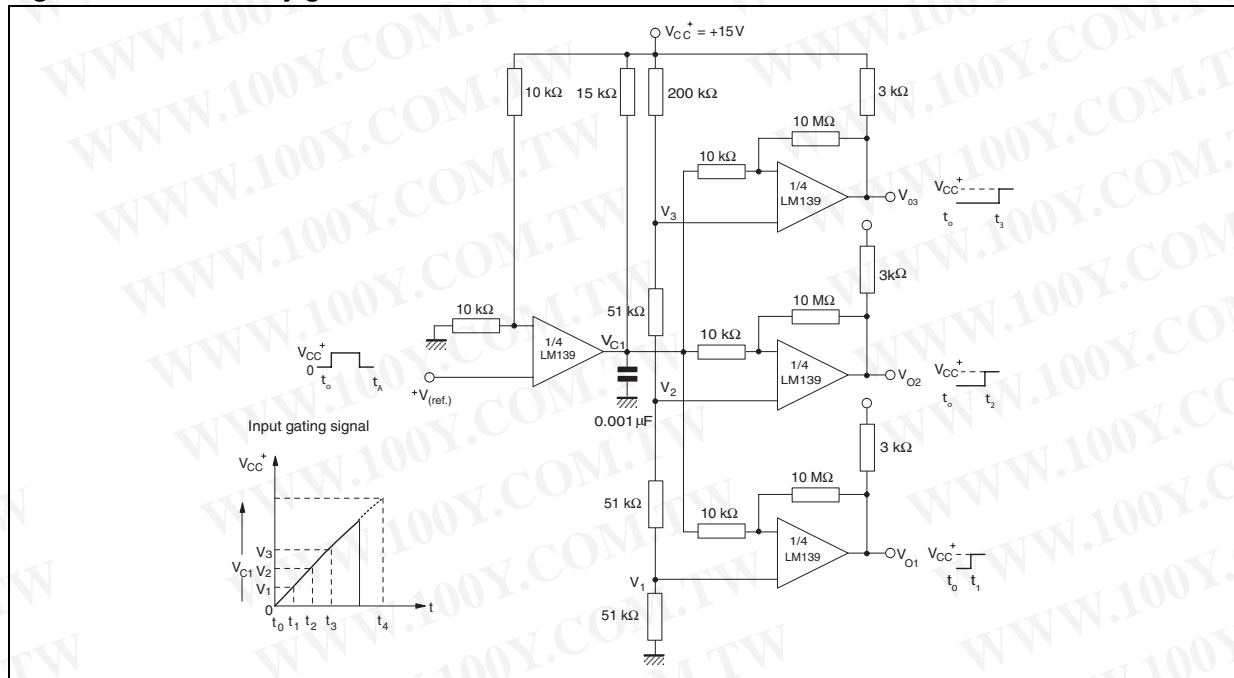

Figure 15. Low frequency op amp with offset adjust

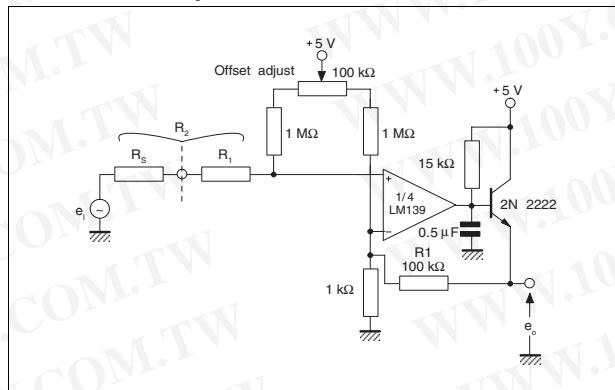

Figure 16. Zero crossing detector (single power supply)

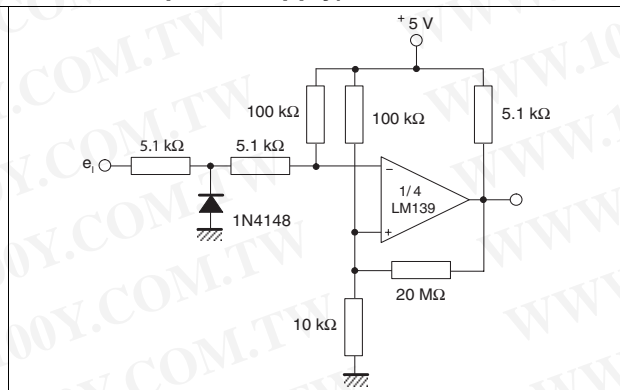

Figure 17. Two-decade high-frequency VCO

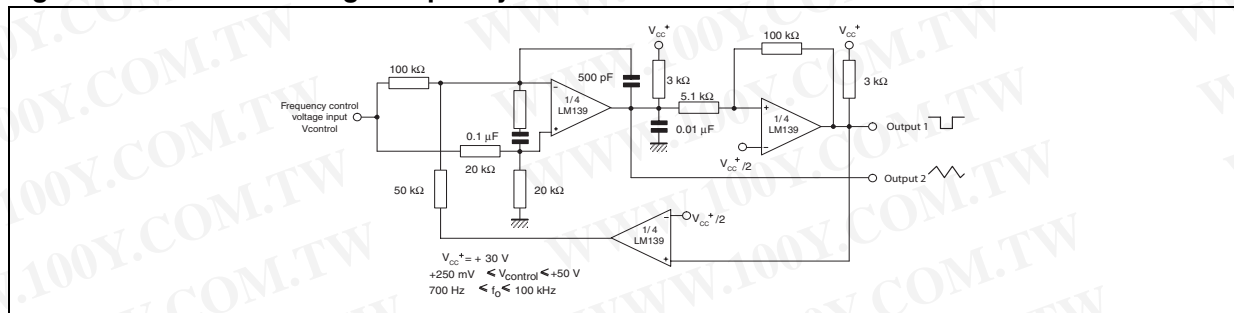

Figure 18. Limit comparator

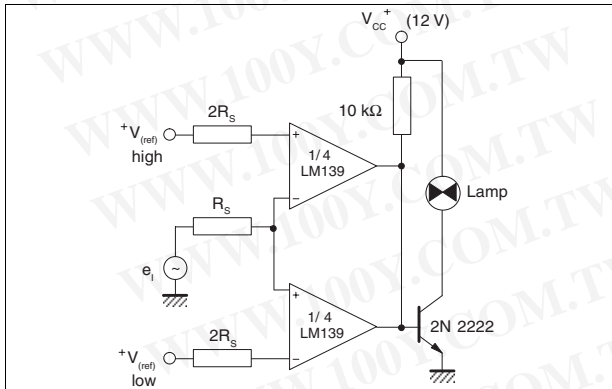

Figure 19. Crystal-controlled oscillator

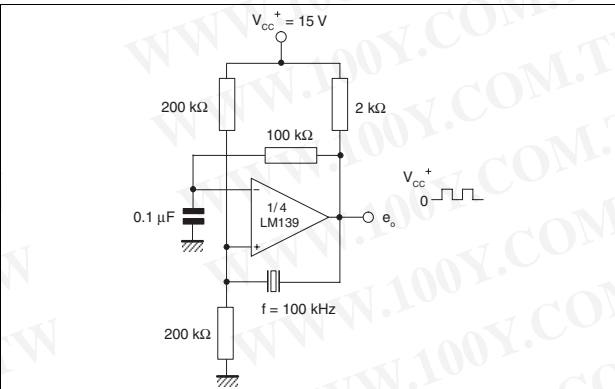

Figure 20. Zero crossing detector

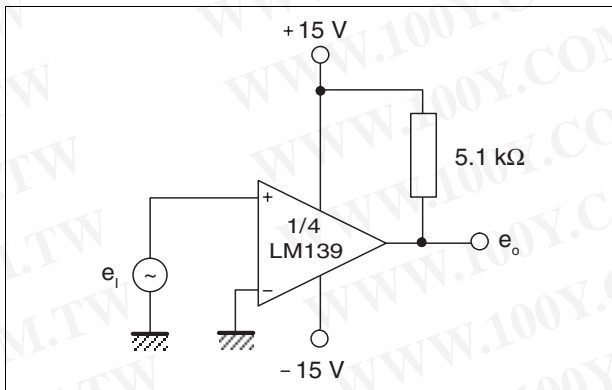
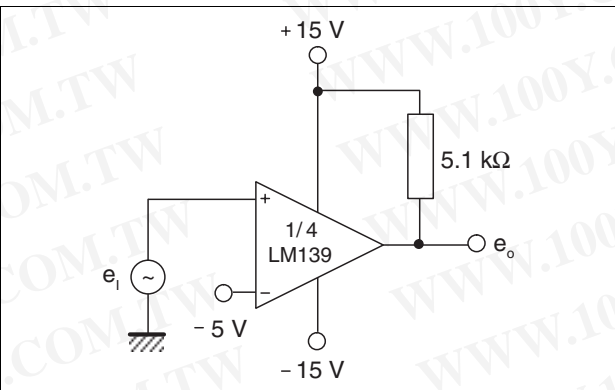

Figure 21. Comparator with a negative reference



勝特力材料 886-3-5753170
 勝特力电子(上海) 86-21-34970699
 勝特力电子(深圳) 86-755-83298787
[Http://www.100y.com.tw](http://www.100y.com.tw)

6 Package information

In order to meet environmental requirements, ST offers these devices in different grades of ECOPACK® packages, depending on their level of environmental compliance. ECOPACK® specifications, grade definitions and product status are available at: www.st.com. ECOPACK® is an ST trademark.

勝特力材料 886-3-5753170
勝特力电子(上海) 86-21-34970699
勝特力电子(深圳) 86-755-83298787
[Http://www.100y.com.tw](http://www.100y.com.tw)

6.1 DIP14 package information

Figure 22. DIP14 package mechanical drawing

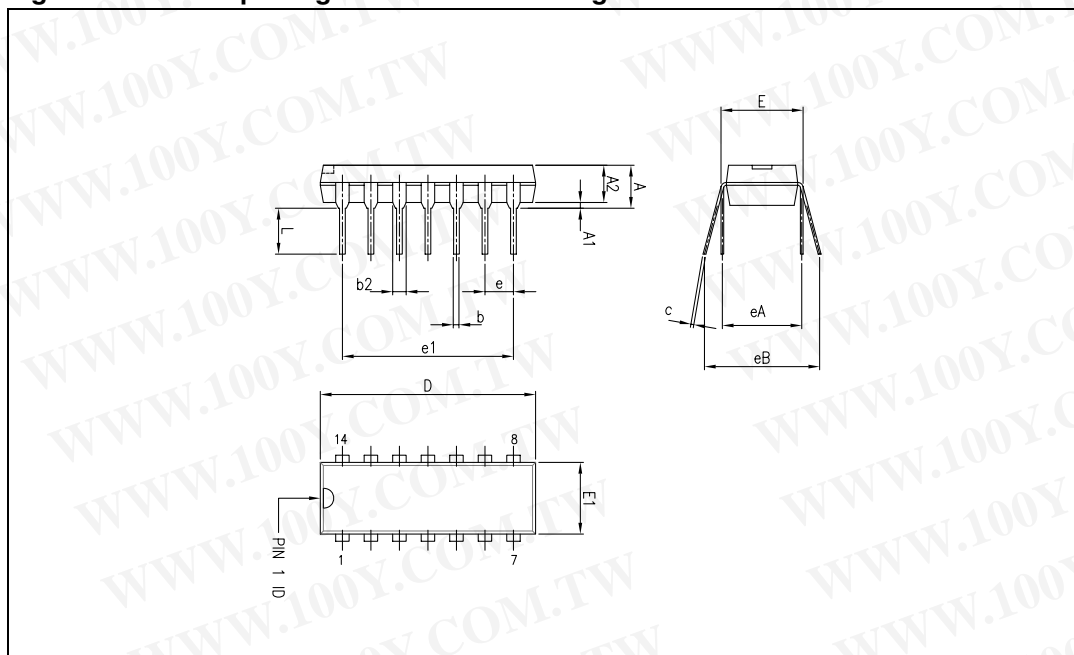

Table 4. DIP14 package mechanical data

Ref.	Dimensions					
	Millimeters			Inches		
	Min.	Typ.	Max.	Min.	Typ.	Max.
A			5.33			0.21
A1	0.38			0.015		
A2	2.92	3.30	4.95	0.11	0.13	0.19
b	0.36	0.46	0.56	0.014	0.018	0.022
b2	1.14	1.52	1.78	0.04	0.06	0.07
c	0.20	0.25	0.36	0.007	0.009	0.01
D	18.67	19.05	19.69	0.73	0.75	0.77
E	7.62	7.87	8.26	0.30	0.31	0.32
E1	6.10	6.35	7.11	0.24	0.25	0.28
e		2.54			0.10	
e1		15.24			0.60	
eA		7.62			0.30	
eB			10.92			0.43
L	2.92	3.30	3.81	0.11	0.13	0.15

6.2 SO-14 package information

Figure 23. SO-14 package mechanical drawing

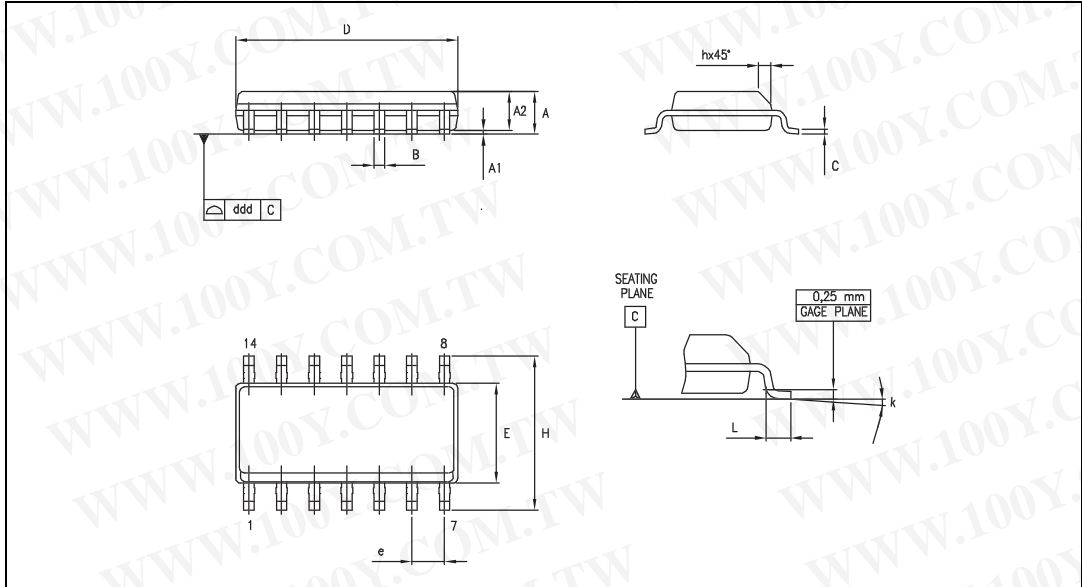

Table 5. SO-14 package mechanical data

Ref.	Dimensions					
	Millimeters			Inches		
	Min.	Typ.	Max.	Min.	Typ.	Max.
A	1.35		1.75	0.05		0.068
A1	0.10		0.25	0.004		0.009
A2	1.10		1.65	0.04		0.06
B	0.33		0.51	0.01		0.02
C	0.19		0.25	0.007		0.009
D	8.55		8.75	0.33		0.34
E	3.80		4.0	0.15		0.15
e		1.27			0.05	
H	5.80		6.20	0.22		0.24
h	0.25		0.50	0.009		0.02
L	0.40		1.27	0.015		0.05
k	8° (max.)					
ddd			0.10			0.004

6.3 QFN16 3x3 package information

Figure 24. QFN16 3x3 package mechanical drawing

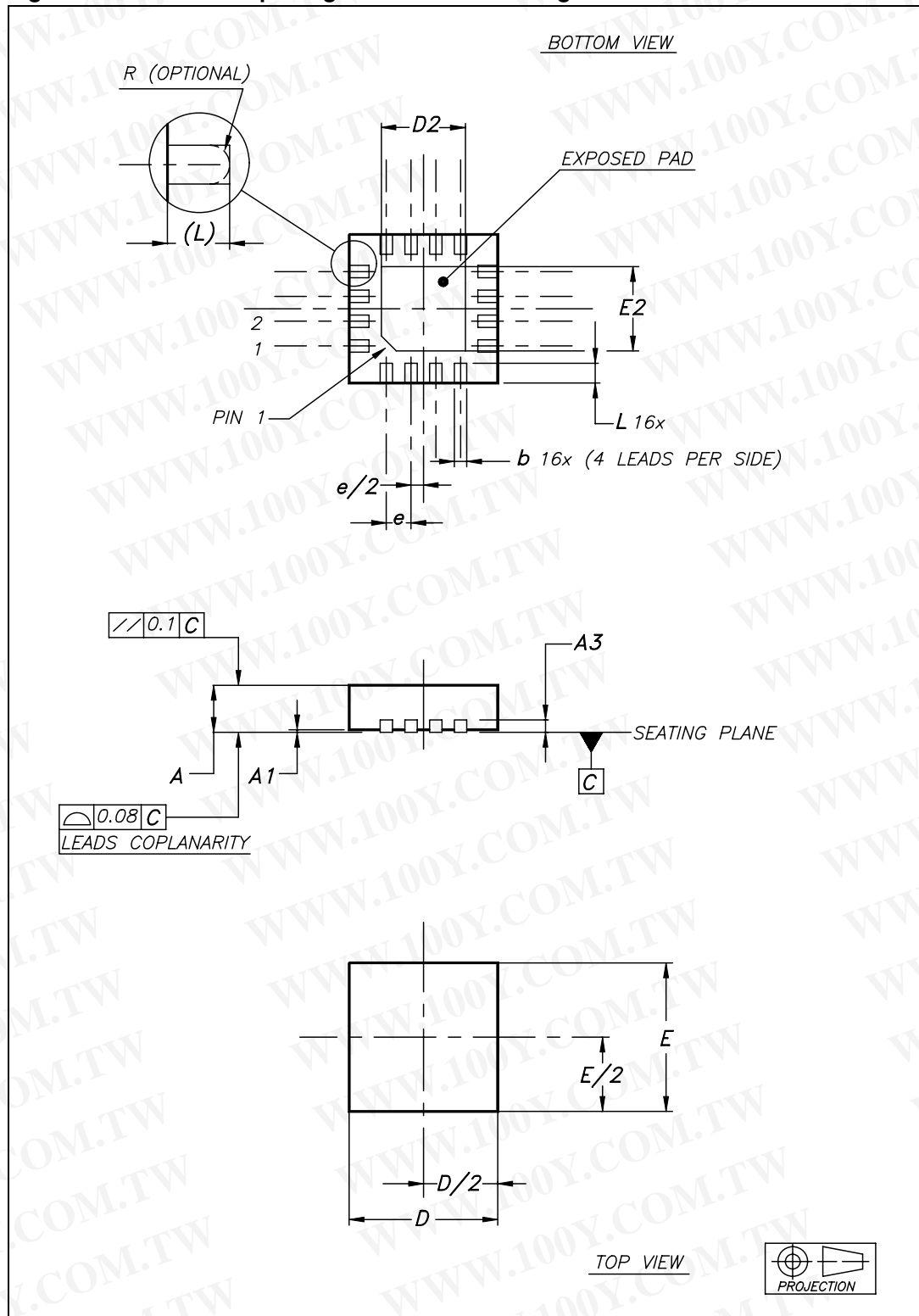
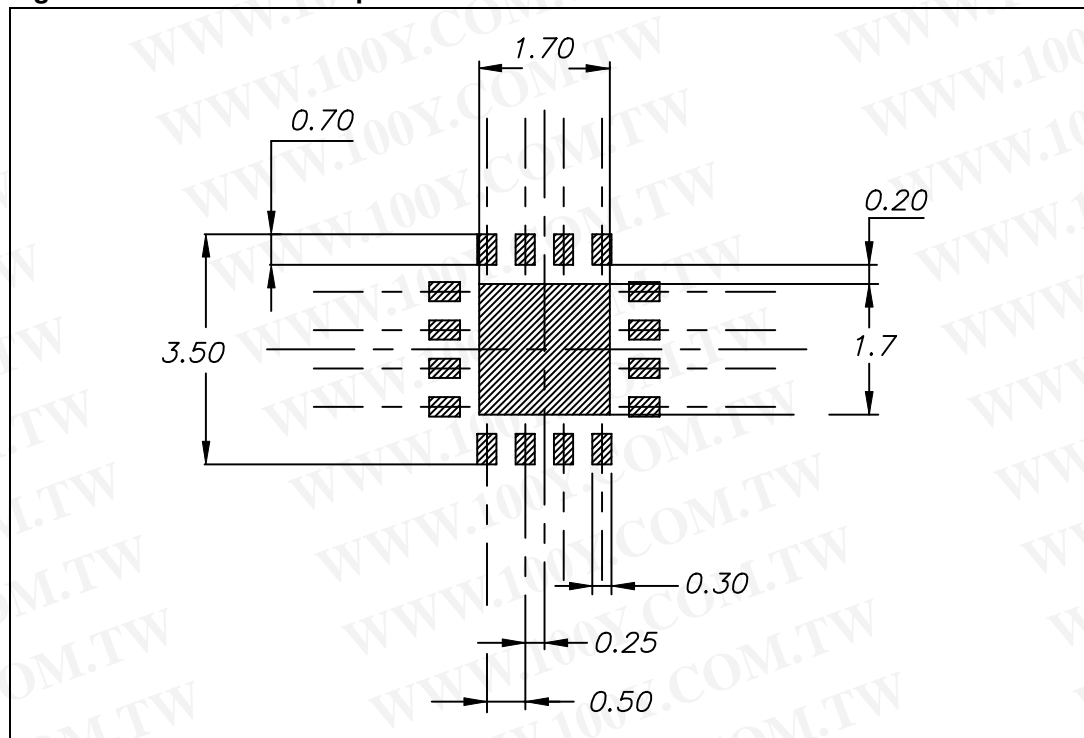

Table 6. QFN16 3x3 mm package mechanical data (pitch 0.5 mm)

Ref.	Dimensions					
	Millimeters			Inches		
	Min.	Typ.	Max.	Min.	Typ.	Max.
A	0.80	0.90	1.00	0.031	0.035	0.039
A1	0		0.05	0		0.002
A3		0.20			0.008	
b	0.18		0.30	0.007		0.012
D	2.90	3.00	3.10	0.114	0.118	0.122
D2	1.50		1.80	0.059		0.071
E	2.90	3.00	3.10	0.114	0.118	0.122
E2	1.50		1.80	0.059		0.071
e		0.50			0.020	
L	0.30		0.50	0.012		0.020

Figure 25. QFN16 3x3 footprint recommendation



勝特力材料 886-3-5753170
 勝特力电子(上海) 86-21-34970699
 勝特力电子(深圳) 86-755-83298787
[Http://www.100y.com.tw](http://www.100y.com.tw)

6.4 TSSOP14 package information

Figure 26. TSSOP14 package mechanical drawing

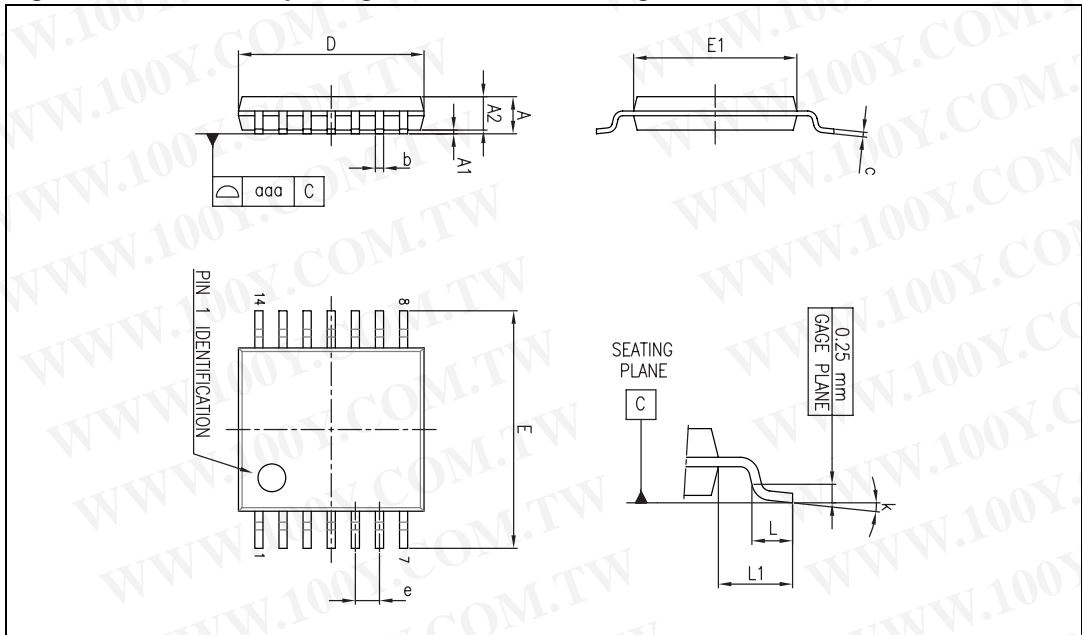

Table 7. TSSOP14 package mechanical data

Ref.	Dimensions					
	Millimeters			Inches		
	Min.	Typ.	Max.	Min.	Typ.	Max.
A			1.20			0.047
A1	0.05		0.15	0.002	0.004	0.006
A2	0.80	1.00	1.05	0.031	0.039	0.041
b	0.19		0.30	0.007		0.012
c	0.09		0.20	0.004		0.0089
D	4.90	5.00	5.10	0.193	0.197	0.201
E	6.20	6.40	6.60	0.244	0.252	0.260
E1	4.30	4.40	4.50	0.169	0.173	0.176
e		0.65			0.0256	
L	0.45	0.60	0.75	0.018	0.024	0.030
L1		1.00			0.039	
k	0°		8°	0°		8°
aaa			0.10			0.004

勝特力材料 886-3-5753170
 勝特力电子(上海) 86-21-34970699
 勝特力电子(深圳) 86-755-83298787
[Http://www.100y.com.tw](http://www.100y.com.tw)

7 Ordering information

Table 8. Order codes

Part number	Temperature range	Package	Packing	Marking
LM139N LM139AN	-55° C, +125° C	DIP14	Tube	LM139N LM139AN
LM139D LM139AD		SO-14	Tube	139 139A
LM139DT LM139ADT		SO-14	Tape & reel	139 139A
LM139PT LM139APT		TSSOP14	Tape & reel	139 139A
LM239N LM239AN	-40° C, +105° C	DIP14	Tube	LM239N LM239AN
LM239D LM239AD		SO-14	Tube	239 239A
LM239DT LM239ADT		SO-14	Tape & reel	239 239A
LM239PT LM239APT		TSSOP14	Tape & reel	239 239A
LM239QT		QFN16 3x3	Tape & reel	K549
LM339N LM339AN	0° C, +70° C	DIP14	Tube	LM339N LM339AN
LM339D LM339AD		SO-14	Tube	339 339A
LM339DT LM339ADT		SO-14	Tape & reel	339 339A
LM339PT LM339APT		TSSOP14	Tape & reel	339 339A
LM339QT		QFN16 3x3	Tape & reel	K551

勝特力材料 886-3-5753170
 勝特力电子(上海) 86-21-34970699
 勝特力电子(深圳) 86-755-83298787
[Http://www.100y.com.tw](http://www.100y.com.tw)

8 Revision history

Table 9. Document revision history

Date	Revision	Changes
01-Mar-2003	1	Initial release.
28-Apr-2009	2	Updated document format. Removed power dissipation from Table 1: Absolute maximum ratings . Added R_{THJA} , R_{THJC} , ESD and T_{LEAD} values to Table 1 . Updated package information in Chapter 6 . Added Table 8: Order codes .
13-Jul-2011	3	Added pin connections for QFN16 package in Figure 1 on page 2 . Added thermal information for QFN16 package in Table 1 on page 3 . Added QFN16 package information in Chapter 6 . Added order codes for QFN16 package in Table 8: Order codes .

勝特力材料 886-3-5753170
 勝特力电子(上海) 86-21-34970699
 勝特力电子(深圳) 86-755-83298787
[Http://www.100y.com.tw](http://www.100y.com.tw)

勝特力材料 886-3-5753170
勝特力电子(上海) 86-21-34970699
勝特力电子(深圳) 86-755-83298787
[Http://www.100y.com.tw](http://www.100y.com.tw)

Please Read Carefully:

Information in this document is provided solely in connection with ST products. STMicroelectronics NV and its subsidiaries ("ST") reserve the right to make changes, corrections, modifications or improvements, to this document, and the products and services described herein at any time, without notice.

All ST products are sold pursuant to ST's terms and conditions of sale.

Purchasers are solely responsible for the choice, selection and use of the ST products and services described herein, and ST assumes no liability whatsoever relating to the choice, selection or use of the ST products and services described herein.

No license, express or implied, by estoppel or otherwise, to any intellectual property rights is granted under this document. If any part of this document refers to any third party products or services it shall not be deemed a license grant by ST for the use of such third party products or services, or any intellectual property contained therein or considered as a warranty covering the use in any manner whatsoever of such third party products or services or any intellectual property contained therein.

UNLESS OTHERWISE SET FORTH IN ST'S TERMS AND CONDITIONS OF SALE ST DISCLAIMS ANY EXPRESS OR IMPLIED WARRANTY WITH RESPECT TO THE USE AND/OR SALE OF ST PRODUCTS INCLUDING WITHOUT LIMITATION IMPLIED WARRANTIES OF MERCHANTABILITY, FITNESS FOR A PARTICULAR PURPOSE (AND THEIR EQUIVALENTS UNDER THE LAWS OF ANY JURISDICTION), OR INFRINGEMENT OF ANY PATENT, COPYRIGHT OR OTHER INTELLECTUAL PROPERTY RIGHT.

UNLESS EXPRESSLY APPROVED IN WRITING BY AN AUTHORIZED ST REPRESENTATIVE, ST PRODUCTS ARE NOT RECOMMENDED, AUTHORIZED OR WARRANTED FOR USE IN MILITARY, AIR CRAFT, SPACE, LIFE SAVING, OR LIFE SUSTAINING APPLICATIONS, NOR IN PRODUCTS OR SYSTEMS WHERE FAILURE OR MALFUNCTION MAY RESULT IN PERSONAL INJURY, DEATH, OR SEVERE PROPERTY OR ENVIRONMENTAL DAMAGE. ST PRODUCTS WHICH ARE NOT SPECIFIED AS "AUTOMOTIVE GRADE" MAY ONLY BE USED IN AUTOMOTIVE APPLICATIONS AT USER'S OWN RISK.

Resale of ST products with provisions different from the statements and/or technical features set forth in this document shall immediately void any warranty granted by ST for the ST product or service described herein and shall not create or extend in any manner whatsoever, any liability of ST.

ST and the ST logo are trademarks or registered trademarks of ST in various countries.

Information in this document supersedes and replaces all information previously supplied.

The ST logo is a registered trademark of STMicroelectronics. All other names are the property of their respective owners.

© 2011 STMicroelectronics - All rights reserved

STMicroelectronics group of companies

Australia - Belgium - Brazil - Canada - China - Czech Republic - Finland - France - Germany - Hong Kong - India - Israel - Italy - Japan - Malaysia - Malta - Morocco - Philippines - Singapore - Spain - Sweden - Switzerland - United Kingdom - United States of America

www.st.com

