

FEATURES

SigmaDSP 28-/56-bit, 50 MIPS digital audio processor
Fully programmable with SigmaStudio graphical tool
24-bit stereo audio ADC and DAC: >98 dB SNR
Sampling rates from 8 kHz to 96 kHz
Low power: 7 mW record, 7 mW playback, 48 kHz at 1.8 V
6 analog input pins, configurable for single-ended or differential inputs
Flexible analog input/output mixers
Stereo digital microphone input
Analog outputs: 2 differential stereo, 2 single-ended stereo, 1 mono headphone output driver
PLL supporting input clocks from 8 MHz to 27 MHz
Analog automatic level control (ALC)
Microphone bias reference voltage
Analog and digital I/O: 1.8 V to 3.65 V
I²C and SPI control interfaces
Digital audio serial data I/O: stereo and time-division multiplexing (TDM) modes
Software-controllable clickless mute
Software power-down
GPIO pins for digital controls and outputs
32-lead, 5 mm × 5 mm LFCSP
-40°C to +85°C operating temperature range

APPLICATIONS

Smartphones/multimedia phones
Digital still cameras/digital video cameras
Portable media players/portable audio players
Phone accessories products

GENERAL DESCRIPTION

The ADAU1761 is a low power, stereo audio codec with integrated digital audio processing that supports stereo 48 kHz record and playback at 14 mW from a 1.8 V analog supply. The stereo audio ADCs and DACs support sample rates from 8 kHz to 96 kHz as well as a digital volume control.

The SigmaDSP® core features 28-bit processing (56-bit double precision). The processor allows system designers to compensate for the real-world limitations of microphones, speakers, amplifiers, and listening environments, resulting in a dramatic improvement in the perceived audio quality through equalization, multiband compression, limiting, and third-party branded algorithms.

The SigmaStudio™ graphical development tool is used to program the ADAU1761. This software includes audio processing blocks such as filters, dynamics processors, mixers, and low level DSP functions for fast development of custom signal flows.

The record path includes an integrated microphone bias circuit and six inputs. The inputs can be mixed and muxed before the ADC, or they can be configured to bypass the ADC. The ADAU1761 includes a stereo digital microphone input.

The ADAU1761 includes five high power output drivers (two differential and three single-ended), supporting stereo headphones, an earpiece, or other output transducer. AC-coupled or capless configurations are supported. Individual fine level controls are supported on all analog outputs. The output mixer stage allows for flexible routing of audio.

FUNCTIONAL BLOCK DIAGRAM

Figure 1.

勝特力材料 886-3-5753170
 勝特力电子(上海) 86-21-34970699
 勝特力电子(深圳) 86-755-83298787
[Http://www.100y.com.tw](http://www.100y.com.tw)

Rev. E

[Document Feedback](#)

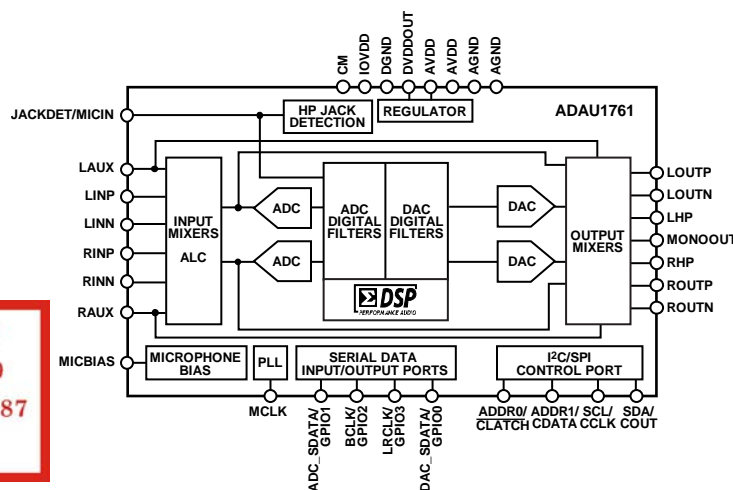
Information furnished by Analog Devices is believed to be accurate and reliable. However, no responsibility is assumed by Analog Devices for its use, nor for any infringements of patents or other rights of third parties that may result from its use. Specifications subject to change without notice. No license is granted by implication or otherwise under any patent or patent rights of Analog Devices. Trademarks and registered trademarks are the property of their respective owners.

One Technology Way, P.O. Box 9106, Norwood, MA 02062-9106, U.S.A.
 Tel: 781.329.4700 ©2009–2018 Analog Devices, Inc. All rights reserved.
[Technical Support](#) www.analog.com

TABLE OF CONTENTS

| | | | |
|---|----|--|----|
| Features | 1 | Playback Signal Path | 35 |
| Applications | 1 | Output Signal Paths | 35 |
| General Description | 1 | Headphone Output | 36 |
| Functional Block Diagram | 1 | Pop-and-Click Suppression | 37 |
| Revision History | 3 | Line Outputs | 37 |
| Specifications | 4 | Control Ports | 38 |
| Analog Performance Specifications | 4 | Burst Mode Writing and Reading | 38 |
| Power Supply Specifications | 7 | I ² C Port | 38 |
| Typical Current Consumption | 8 | SPI Port | 41 |
| Typical Power Management Measurements | 9 | Serial Data Input/Output Ports | 42 |
| Digital Filters | 10 | Applications Information | 44 |
| Digital Input/Output Specifications | 10 | Power Supply Bypass Capacitors | 44 |
| Digital Timing Specifications | 11 | GSM Noise Filter | 44 |
| Digital Timing Diagrams | 12 | Grounding | 44 |
| Absolute Maximum Ratings | 14 | Exposed Pad PCB Design | 44 |
| Thermal Resistance | 14 | DSP Core | 45 |
| ESD Caution | 14 | Signal Processing | 45 |
| Pin Configuration and Function Descriptions | 15 | Architecture | 45 |
| Typical Performance Characteristics | 17 | Program Counter | 45 |
| System Block Diagrams | 20 | Features | 45 |
| Theory of Operation | 23 | Startup | 45 |
| Startup, Initialization, and Power | 24 | Numeric Formats | 46 |
| Power-Up Sequence | 24 | Programming | 46 |
| Power Reduction Modes | 24 | Program RAM, Parameter RAM, and Data RAM | 47 |
| Digital Power Supply | 24 | Program RAM | 47 |
| Input/Output Power Supply | 24 | Parameter RAM | 47 |
| Clock Generation and Management | 24 | Data RAM | 47 |
| Clocking and Sampling Rates | 26 | Read/Write Data Formats | 47 |
| Core Clock | 26 | Software Safeload | 48 |
| Sampling Rates | 27 | Software Slew | 49 |
| PLL | 27 | General-Purpose Input/Output | 50 |
| Record Signal Path | 29 | GPIO Pins Set from the Control Port | 50 |
| Input Signal Paths | 29 | Control Registers | 51 |
| Analog-to-Digital Converters | 31 | Control Register Details | 52 |
| Automatic Level Control (ALC) | 32 | Outline Dimensions | 93 |
| ALC Parameters | 32 | Ordering Guide | 93 |
| Noise Gate Function | 33 | | |

REVISION HISTORY**10/2018—Rev. D to Rev. E**

| | |
|---------------------------------|----|
| Change to Figure 7 | 15 |
| Updated Outline Dimensions..... | 93 |
| Changes to Ordering Guide..... | 93 |

7/2018—Rev. C to Rev. D

| | |
|--|----|
| Changed t_{SODM} Serial Port Parameter to t_{SOD} Serial Port Parameter, Table 7 | 11 |
| Changes to t_{SOD} Serial Port Parameter, Table 7..... | 11 |
| Changes to Figure 3..... | 12 |
| Changes to Figure 7..... | 15 |
| Updated Outline Dimensions..... | 93 |
| Changes to Ordering Guide..... | 93 |

9/2010—Rev. B to Rev. C

| | |
|--------------------------|---|
| Changes to Figure 1..... | 1 |
|--------------------------|---|

5/2010—Rev. A to Rev. B

| | |
|--|----|
| Changes to Burst Mode Writing and Reading Section | 38 |
| Changes to Table 33 | 51 |
| Added R67: Dejitter Control, 16,438 (0x4036) Section | 79 |

12/2009—Rev. 0 to Rev. A

| | |
|--|----|
| Changes to Features Section | 1 |
| Change to General Description Section..... | 1 |
| Changes to Table 1 | 6 |
| Change to Table 5 | 10 |
| Changes to Figure 6..... | 13 |
| Changes to Table 10 | 15 |
| Changes to Captions of Figure 15, Figure 16, Figure 18, and Figure 19 | 18 |
| Changes to Captions of Figure 21 and Figure 24 | 19 |
| Added Figure 25; Renumbered Sequentially..... | 19 |
| Change to Figure 26 | 20 |
| Change to Figure 27 | 21 |
| Change to Figure 28 | 22 |
| Change to Theory of Operation Section..... | 23 |
| Changes to Power Reduction Modes Section and Case 1: PLL Is Bypassed Section | 24 |
| Changes to PLL Lock Acquisition Section..... | 25 |
| Changes to Core Clock Section and Figure 30..... | 26 |
| Change to Sampling Rates Section..... | 27 |

| | |
|--|----|
| Changes to Input Signal Paths Section and Figure 32..... | 29 |
| Changes to Figure 33 and Figure 34 | 30 |
| Changes to ADC Full-Scale Level Section..... | 31 |
| Change to Automatic Level Control (ALC) Section | 32 |
| Changes to Output Signal Paths Section..... | 35 |
| Changes to Headphone Output Section..... | 36 |
| Changes to Jack Detection Section, Pop-and-Click Suppression Section, and Line Outputs Section | 37 |
| Changes to Control Ports Section and I ² C Port Section | 38 |
| Added Burst Mode Writing and Reading Section | 38 |
| Changes to SPI Port Section | 41 |
| Changes to Serial Data Input/Output Ports Section and Table 25..... | 42 |
| Added Figure 57 | 42 |
| Changes to Architecture Section and Figure 67..... | 45 |
| Added Startup Section..... | 45 |
| Changes to Parameter RAM Section and Data RAM Section .. | 47 |
| Changes to Table 33 | 51 |
| Changes to R2: Digital Microphone/Jack Detection Control, 16,392 (0x4008) Section and Table 36..... | 54 |
| Changes to Table 42 | 58 |
| Changes to Table 43 | 59 |
| Changes to R15: Serial Port Control 0, 16,405 (0x4015) Section and Table 49 | 63 |
| Change to Table 50..... | 64 |
| Changes to Table 51, R18: Converter Control 1, 16,408 (0x4018) Section, and Table 52 | 65 |
| Changes to Table 60, R27: Playback L/R Mixer Right (Mixer 6) Line Output Control, 16,417 (0x4021) Section, and Table 61...71 | 71 |
| Changes to Table 62, R29: Playback Headphone Left Volume Control, 16,419 (0x4023) Section, and Table 63 | 72 |
| Changes to Table 64 | 73 |
| Changes to R42: Jack Detect Pin Control, 16,433 (0x4031) Section and Table 76..... | 79 |
| Changes to R57: DSP Sampling Rate Setting, 16,619 (0x40EB) Section and Table 81 | 81 |
| Change to Table 85..... | 83 |
| Change to Table 88..... | 84 |
| Changes to R66: Clock Enable 1, 16,634 (0x40FA) Section and Table 90..... | 85 |

1/2009—Revision 0: Initial Version

SPECIFICATIONS

Supply voltage (AVDD) = 3.3 V, T_A = 25°C, master clock = 12.288 MHz (48 kHz f_s, 256 × f_s mode), input sample rate = 48 kHz, measurement bandwidth = 20 Hz to 20 kHz, word width = 24 bits, C_{LOAD} (digital output) = 20 pF, I_{LOAD} (digital output) = 2 mA, V_{IH} = 2 V, V_{IL} = 0.8 V, unless otherwise noted. Performance of all channels is identical, exclusive of the interchannel gain mismatch and interchannel phase deviation specifications.

ANALOG PERFORMANCE SPECIFICATIONS

Specifications guaranteed at 25°C (ambient).

Table 1.

| Parameter | Test Conditions/Comments | Min | Typ | Max | Unit |
|-------------------------------------|---|-----|-------------|-----|---------------|
| ANALOG-TO-DIGITAL CONVERTERS | | | | | |
| | ADC performance excludes mixers and PGA | | | | |
| ADC Resolution | All ADCs | | 24 | | Bits |
| Digital Attenuation Step | | | 0.375 | | dB |
| Digital Attenuation Range | | | 95 | | dB |
| INPUT RESISTANCE | | | | | |
| Single-Ended Line Input | –12 dB gain | | 83 | | kΩ |
| | 0 dB gain | | 21 | | kΩ |
| | 6 dB gain | | 10.5 | | kΩ |
| PGA Inverting Inputs | –12 dB gain | | 84.5 | | kΩ |
| | 0 dB gain | | 53 | | kΩ |
| | 35.25 dB gain | | 2 | | kΩ |
| PGA Noninverting Inputs | All gains | | 105 | | kΩ |
| SINGLE-ENDED LINE INPUT | | | | | |
| Full-Scale Input Voltage (0 dB) | Scales linearly with AVDD | | AVDD/3.3 | | V rms |
| | AVDD = 1.8 V | | 0.55 (1.56) | | V rms (V p-p) |
| | AVDD = 3.3 V | | 1.0 (2.83) | | V rms (V p-p) |
| Dynamic Range | 20 Hz to 20 kHz, –60 dB input | | | | |
| With A-Weighted Filter (RMS) | AVDD = 1.8 V | | 94 | | dB |
| | AVDD = 3.3 V | | 99 | | dB |
| No Filter (RMS) | AVDD = 1.8 V | | 91 | | dB |
| | AVDD = 3.3 V | | 96 | | dB |
| Total Harmonic Distortion + Noise | –1 dBFS | | | | |
| | AVDD = 1.8 V | | –88 | | dB |
| | AVDD = 3.3 V | | –90 | | dB |
| Signal-to-Noise Ratio | | | | | |
| With A-Weighted Filter (RMS) | AVDD = 1.8 V | | 94 | | dB |
| | AVDD = 3.3 V | | 99 | | dB |
| No Filter (RMS) | AVDD = 1.8 V | | 91 | | dB |
| | AVDD = 3.3 V | | 96 | | dB |
| Gain per Step | | | 3 | | dB |
| Total Gain Range | | –12 | | +6 | dB |
| Mute Attenuation | | | –87 | | dB |
| Interchannel Gain Mismatch | | | 0.005 | | dB |
| Offset Error | | | 0 | | mV |
| Gain Error | | | –12 | | % |
| Interchannel Isolation | | | 68 | | dB |
| Power Supply Rejection Ratio | CM capacitor = 20 μF | | | | |
| | 100 mV p-p @ 217 Hz | | 65 | | dB |
| | 100 mV p-p @ 1 kHz | | 67 | | dB |

| Parameter | Test Conditions/Comments | Min | Typ | Max | Unit |
|--------------------------------------|--|-----|---------------------------------------|--------|---|
| PSEUDO-DIFFERENTIAL PGA INPUT | | | | | |
| Full-Scale Input Voltage (0 dB) | Scales linearly with AVDD AVDD = 1.8 V AVDD = 3.3 V | | AVDD/3.3 0.55 (1.56) 1.0 (2.83) | | V rms V rms (V p-p) V rms (V p-p) |
| Dynamic Range | 20 Hz to 20 kHz, –60 dB input | | | | |
| With A-Weighted Filter (RMS) | AVDD = 1.8 V AVDD = 3.3 V | | 92 98 | | dB dB |
| No Filter (RMS) | AVDD = 1.8 V AVDD = 3.3 V | | 90 95 | | dB dB |
| Total Harmonic Distortion + Noise | –1 dBFS AVDD = 1.8 V AVDD = 3.3 V | | | | |
| | | | –88 –89 | | dB dB |
| Signal-to-Noise Ratio | | | | | |
| With A-Weighted Filter (RMS) | AVDD = 1.8 V AVDD = 3.3 V | | 92 98 | | dB dB |
| No Filter (RMS) | AVDD = 1.8 V AVDD = 3.3 V | | 90 95 | | dB dB |
| Volume Control Step | PGA gain | | 0.75 | | dB |
| Volume Control Range | PGA gain | –12 | | +35.25 | dB |
| PGA Boost | | | 20 | | dB |
| Mute Attenuation | | | –87 | | dB |
| Interchannel Gain Mismatch | | | 0.005 | | dB |
| Offset Error | | | 0 | | mV |
| Gain Error | | | –14 | | % |
| Interchannel Isolation | | | 83 | | dB |
| Common-Mode Rejection Ratio | 100 mV rms, 1 kHz 100 mV rms, 20 kHz | | 65 65 | | dB dB |
| FULL DIFFERENTIAL PGA INPUT | | | | | |
| Full-Scale Input Voltage (0 dB) | Differential PGA inputs Scales linearly with AVDD AVDD = 1.8 V AVDD = 3.3 V | | AVDD/3.3 0.55 (1.56) 1.0 (2.83) | | V rms V rms (V p-p) V rms (V p-p) |
| Dynamic Range | 20 Hz to 20 kHz, –60 dB input | | | | |
| With A-Weighted Filter (RMS) | AVDD = 1.8 V AVDD = 3.3 V | | 92 98 | | dB dB |
| No Filter (RMS) | AVDD = 1.8 V AVDD = 3.3 V | | 90 95 | | dB dB |
| Total Harmonic Distortion + Noise | –1 dBFS AVDD = 1.8 V AVDD = 3.3 V | | | | |
| | | | –70 –78 | | dB dB |
| Signal-to-Noise Ratio | | | | | |
| With A-Weighted Filter (RMS) | AVDD = 1.8 V AVDD = 3.3 V | | 92 98 | | dB dB |
| No Filter (RMS) | AVDD = 1.8 V AVDD = 3.3 V | | 90 95 | | dB dB |
| Volume Control Step | PGA gain | | 0.75 | | dB |
| Volume Control Range | PGA gain | –12 | | +35.25 | dB |
| PGA Boost | | | 20 | | dB |
| Mute Attenuation | | | –87 | | dB |
| Interchannel Gain Mismatch | | | 0.005 | | dB |
| Offset Error | | | 0 | | mV |
| Gain Error | | | –14 | | % |

| Parameter | Test Conditions/Comments | Min | Typ | Max | Unit |
|-----------------------------------|---|-----|-------------|-----|---------------|
| Interchannel Isolation | | | 83 | | dB |
| Common-Mode Rejection Ratio | 100 mV rms, 1 kHz | | 65 | | dB |
| | 100 mV rms, 20 kHz | | 65 | | dB |
| MICROPHONE BIAS | MBIEN = 1 | | | | |
| Bias Voltage | | | | | V |
| 0.65 × AVDD | AVDD = 1.8 V, MBI = 1 | | 1.17 | | V |
| | AVDD = 3.3 V, MBI = 1 | | 2.145 | | V |
| 0.90 × AVDD | AVDD = 1.8 V, MBI = 0 | | 1.62 | | V |
| | AVDD = 3.3 V, MBI = 0 | | 2.97 | | V |
| Bias Current Source | AVDD = 3.3 V, MBI = 0, MPERF = 1 | | | 3 | mA |
| Noise in the Signal Bandwidth | AVDD = 3.3 V, 1 kHz to 20 kHz | | | | nV/√Hz |
| | MBI = 0, MPERF = 0 | | 42 | | nV/√Hz |
| | MBI = 0, MPERF = 1 | | 85 | | nV/√Hz |
| | MBI = 1, MPERF = 0 | | 25 | | nV/√Hz |
| | MBI = 1, MPERF = 1 | | 37 | | nV/√Hz |
| DIGITAL-TO-ANALOG CONVERTERS | DAC performance excludes mixers and headphone amplifier | | | | |
| DAC Resolution | All DACs | | 24 | | Bits |
| Digital Attenuation Step | | | 0.375 | | dB |
| Digital Attenuation Range | | | 95 | | dB |
| DAC TO LINE OUTPUT | | | | | |
| Full-Scale Output Voltage (0 dB) | Scales linearly with AVDD | | AVDD/3.3 | | V rms |
| | AVDD = 1.8 V | | 0.50 (1.41) | | V rms (V p-p) |
| | AVDD = 3.3 V | | 0.92 (2.60) | | V rms (V p-p) |
| Analog Volume Control Step | Line output volume control | | 0.75 | | dB |
| Analog Volume Control Range | Line output volume control | -57 | 1 | +6 | dB |
| Mute Attenuation | | | -87 | | dB |
| Dynamic Range | 20 Hz to 20 kHz, -60 dB input, line output mode | | | | |
| With A-Weighted Filter (RMS) | AVDD = 1.8 V | | 96 | | dB |
| | AVDD = 3.3 V | | 101 | | dB |
| No Filter (RMS) | AVDD = 1.8 V | | 93.5 | | dB |
| | AVDD = 3.3 V | | 98 | | dB |
| Total Harmonic Distortion + Noise | -1 dBFS, line output mode | | | | dB |
| | AVDD = 1.8 V | | -90 | | dB |
| | AVDD = 3.3 V | | -92 | | dB |
| Signal-to-Noise Ratio | Line output mode | | | | |
| With A-Weighted Filter (RMS) | AVDD = 1.8 V | | 96 | | dB |
| | AVDD = 3.3 V | | 101 | | dB |
| No Filter (RMS) | AVDD = 1.8 V | | 93.5 | | dB |
| | AVDD = 3.3 V | | 98 | | dB |
| Power Supply Rejection Ratio | CM capacitor = 20 μF | | | | |
| | 100 mV p-p @ 217 Hz | | 56 | | dB |
| | 100 mV p-p @ 1 kHz | | 70 | | dB |
| Gain Error | | | 3 | | % |
| Interchannel Gain Mismatch | | | 0.005 | | dB |
| Offset Error | | | 0 | | mV |
| Interchannel Isolation | 1 kHz, 0 dBFS input signal | | 100 | | dB |

| Parameter | Test Conditions/Comments | Min | Typ | Max | Unit |
|-----------------------------------|---|-----|--|-----|---|
| DAC TO HEADPHONE/EARPIECE OUTPUT | P_o = output power per channel | | | | |
| Full-Scale Output Voltage (0 dB) | Scales linearly with AVDD AVDD = 1.8 V AVDD = 3.3 V | | AVDD/3.3 0.50 (1.41) 0.92 (2.60) | | V rms V rms (V p-p) V rms (V p-p) |
| Total Harmonic Distortion + Noise | –4 dBFS | | | | |
| 16 Ω load | AVDD = 1.8 V, P_o = 6.4 mW | | –76 | | dB |
| 32 Ω load | AVDD = 3.3 V, P_o = 21.1 mW AVDD = 1.8 V, P_o = 3.8 mW AVDD = 3.3 V, P_o = 10.6 mW | | –82 –82 –82 | | dB dB dB |
| Power Supply Rejection Ratio | CM capacitor = 20 μ F 100 mV p-p @ 217 Hz | | 56 | | dB |
| Interchannel Isolation | 100 mV p-p @ 1 kHz 1 kHz, 0 dBFS input signal, 32 Ω load, AVDD = 3.3 V Referred to GND Referred to CM (capless headphone mode) | | 67 73 50 | | dB dB dB |
| REFERENCE | | | | | |
| Common-Mode Reference Output | CM pin | | AVDD/2 | | V |

POWER SUPPLY SPECIFICATIONS

Table 2.

| Parameter | Test Conditions/Comments | Min | Typ | Max | Unit |
|-------------------------------------|---|------|------|------|------|
| SUPPLIES | | | | | |
| Voltage | DVDDOUT | | 1.56 | | V |
| | AVDD | 1.8 | 3.3 | 3.65 | V |
| | IOVDD | 1.63 | 3.3 | 3.65 | V |
| Digital I/O Current (IOVDD = 1.8 V) | 20 pF capacitive load on all digital pins | | | | |
| Slave Mode | f_s = 48 kHz | | 0.25 | | mA |
| | f_s = 96 kHz | | 0.48 | | mA |
| Master Mode | f_s = 8 kHz | | 0.07 | | mA |
| | f_s = 48 kHz | | 0.62 | | mA |
| | f_s = 96 kHz | | 1.23 | | mA |
| | f_s = 8 kHz | | 0.11 | | mA |
| Digital I/O Current (IOVDD = 3.3 V) | 20 pF capacitive load on all digital pins | | | | |
| Slave Mode | f_s = 48 kHz | | 0.48 | | mA |
| | f_s = 96 kHz | | 0.9 | | mA |
| | f_s = 8 kHz | | 0.13 | | mA |
| Master Mode | f_s = 48 kHz | | 1.51 | | mA |
| | f_s = 96 kHz | | 3 | | mA |
| | f_s = 8 kHz | | 0.27 | | mA |
| Analog Current (AVDD) | See Table 3 | | | | |

TYPICAL CURRENT CONSUMPTION

Master clock = 12.288 MHz, input sample rate = 48 kHz, input tone = 1 kHz, normal power management settings, ADC input @ -1 dBFS, DAC input @ 0 dBFS. For total power consumption, add the IOVDD current listed in Table 2.

Table 3.

| Operating Voltage | Audio Path | Clock Generation | Typical AVDD Current Consumption (mA) |
|----------------------|---|------------------|---------------------------------------|
| AVDD = IOVDD = 3.3 V | Record stereo differential to ADC | Direct MCLK | 5.24 |
| | | Integer PLL | 6.57 |
| | DAC stereo playback to line output (10 kΩ) | Direct MCLK | 5.55 |
| | | Integer PLL | 6.90 |
| | DAC stereo playback to headphone (16 Ω) | Direct MCLK | 55.5 |
| | | Integer PLL | 56.8 |
| AVDD = IOVDD = 1.8 V | DAC stereo playback to headphone (32 Ω) | Direct MCLK | 30.9 |
| | | Integer PLL | 32.25 |
| | DAC stereo playback to capless headphone (32 Ω) | Direct MCLK | 56.75 |
| | | Integer PLL | 58 |
| | Record aux stereo bypass to line output (10 kΩ) | Direct MCLK | 1.9 |
| | | Integer PLL | 3.3 |
| AVDD = IOVDD = 1.8 V | Record stereo differential to ADC | Direct MCLK | 4.25 |
| | | Integer PLL | 5.55 |
| | DAC stereo playback to line output (10 kΩ) | Direct MCLK | 4.7 |
| | | Integer PLL | 5.7 |
| | DAC stereo playback to headphone (16 Ω) | Direct MCLK | 30.81 |
| | | Integer PLL | 32 |
| AVDD = IOVDD = 1.8 V | DAC stereo playback to headphone (32 Ω) | Direct MCLK | 18.3 |
| | | Integer PLL | 19.5 |
| | DAC stereo playback to capless headphone (32 Ω) | Direct MCLK | 32.6 |
| | | Integer PLL | 33.7 |
| | Record aux stereo bypass to line output (10 kΩ) | Direct MCLK | 1.9 |
| | | Integer PLL | 3.07 |

TYPICAL POWER MANAGEMENT MEASUREMENTS

Master clock = 12.288 MHz, integer PLL, input sample rate = 48 kHz, input tone = 1 kHz. Pseudo-differential input to ADCs, DACs to line output with 10 kΩ load. ADC input @ -1 dBFS, DAC input @ 0 dBFS. In Table 4, the mixer boost and power management conditions are set for MXBIAS[1:0], ADCBIAS[1:0], HPBIAS[1:0], and DACBIAS[1:0]. RBIAS[1:0] and PBIAS[1:0] do not have an extreme power saving mode and are therefore set for power saving mode in the extreme power saving rows in Table 4.

Table 4.

| Operating Voltage | Power Management Setting | Mixer Boost Setting | Typical AVDD Current Consumption (mA) | Typical ADC THD + N (dB) | Typical Line Output THD + N (dB) |
|--------------------------|---------------------------------|----------------------------|--|---------------------------------|---|
| AVDD = IOVDD = 3.3 V | Normal (default) | Normal operation | 9.6 | -91 | -92.5 |
| | | Boost Level 1 | 9.75 | -91.5 | -92.5 |
| | | Boost Level 2 | 9.92 | -91.5 | -92.5 |
| | | Boost Level 3 | 10.25 | -91.5 | -92.5 |
| | Extreme power saving | Normal operation | 7.09 | -84.5 | -87 |
| | | Boost Level 1 | 7.19 | -84.8 | -87.1 |
| | | Boost Level 2 | 7.29 | -84.8 | -87.1 |
| | | Boost Level 3 | 7.49 | -85 | -87.1 |
| | Power saving | Normal operation | 7.67 | -89.5 | -90 |
| | | Boost Level 1 | 7.77 | -89.5 | -90 |
| | | Boost Level 2 | 7.86 | -89.8 | -90 |
| | | Boost Level 3 | 8.07 | -89.8 | -90 |
| | Enhanced performance | Normal operation | 10.55 | -91 | -93.5 |
| | | Boost Level 1 | 10.74 | -91 | -93.5 |
| | | Boost Level 2 | 10.93 | -91 | -93.5 |
| | | Boost Level 3 | 11.33 | -91 | -93.5 |
| AVDD = IOVDD = 1.8 V | Normal (default) | Normal operation | 8.1 | -88 | -91.2 |
| | | Boost Level 1 | 8.26 | -88 | -91.2 |
| | | Boost Level 2 | 8.41 | -88 | -91.2 |
| | | Boost Level 3 | 8.73 | -88 | -91.2 |
| | Extreme power saving | Normal operation | 5.73 | -85 | -86 |
| | | Boost Level 1 | 5.82 | -85.4 | -86 |
| | | Boost Level 2 | 5.91 | -85.5 | -86 |
| | | Boost Level 3 | 6.1 | -85.5 | -86 |
| | Power saving | Normal operation | 6.27 | -86 | -89.4 |
| | | Boost Level 1 | 6.36 | -86.1 | -89.5 |
| | | Boost Level 2 | 6.46 | -86.3 | -89.5 |
| | | Boost Level 3 | 6.65 | -86.3 | -89.5 |
| | Enhanced performance | Normal operation | 9.01 | -88 | -91.5 |
| | | Boost Level 1 | 9.2 | -88 | -91.5 |
| | | Boost Level 2 | 9.38 | -88 | -91.5 |
| | | Boost Level 3 | 9.76 | -88 | -91.5 |

DIGITAL FILTERS

Table 5.

| Parameter | Mode | Factor | Min | Typ | Max | Unit |
|--------------------------|---------------------------|------------------------|-----|--------|-------|------|
| ADC DECIMATION FILTER | All modes, typ @ 48 kHz | | | | | |
| Pass Band | | 0.4375 f _s | | 21 | | kHz |
| Pass-Band Ripple | | | | ±0.015 | | dB |
| Transition Band | | 0.5 f _s | | 24 | | kHz |
| Stop Band | | 0.5625 f _s | | 27 | | kHz |
| Stop-Band Attenuation | | | | 67 | | dB |
| Group Delay | | 22.9844/f _s | | 479 | | µs |
| DAC INTERPOLATION FILTER | | | | | | |
| Pass Band | 48 kHz mode, typ @ 48 kHz | 0.4535 f _s | | 22 | | kHz |
| | 96 kHz mode, typ @ 96 kHz | 0.3646 f _s | | 35 | | kHz |
| Pass-Band Ripple | 48 kHz mode, typ @ 48 kHz | | | | ±0.01 | dB |
| | 96 kHz mode, typ @ 96 kHz | | | | ±0.05 | dB |
| Transition Band | 48 kHz mode, typ @ 48 kHz | 0.5 f _s | | 24 | | kHz |
| | 96 kHz mode, typ @ 96 kHz | 0.5 f _s | | 48 | | kHz |
| Stop Band | 48 kHz mode, typ @ 48 kHz | 0.5465 f _s | | 26 | | kHz |
| | 96 kHz mode, typ @ 96 kHz | 0.6354 f _s | | 61 | | kHz |
| Stop-Band Attenuation | 48 kHz mode, typ @ 48 kHz | | | 69 | | dB |
| | 96 kHz mode, typ @ 96 kHz | | | 68 | | dB |
| Group Delay | 48 kHz mode, typ @ 48 kHz | 25/f _s | | 521 | | µs |
| | 96 kHz mode, typ @ 96 kHz | 11/f _s | | 115 | | µs |

DIGITAL INPUT/OUTPUT SPECIFICATIONS

-40°C < T_A < +85°C, IOVDD = 3.3 V ± 10%.

Table 6.

| Parameter | Test Conditions/Comments | Min | Typ | Max | Unit |
|--|--|-------------|-----|-------|------|
| INPUT SPECIFICATIONS | | | | | |
| Input Voltage High (V _{IH}) | | 0.7 × IOVDD | | | V |
| Input Voltage Low (V _{IL}) | | 0.3 × IOVDD | | | V |
| Input Leakage | | | | | |
| Pull-Ups/Pull-Downs Disabled | I _{IH} @ V _{IH} = 3.3 V | -0.17 | | +0.17 | µA |
| | I _{IL} @ V _{IL} = 0 V | -0.17 | | +0.17 | µA |
| | I _{IL} @ V _{IL} = 0 V (MCLK pin) | -13.5 | | -0.5 | µA |
| Pull-Ups Enabled | I _{IH} @ V _{IH} = 3.3 V | -0.7 | | +0.7 | µA |
| | I _{IL} @ V _{IL} = 0 V | -13.5 | | -0.5 | µA |
| Pull-Downs Enabled | I _{IH} @ V _{IH} = 3.3 V | 2.7 | | 8.3 | µA |
| | I _{IL} @ V _{IL} = 0 V | -0.18 | | +0.18 | µA |
| Input Capacitance | | | | 5 | pF |
| OUTPUT SPECIFICATIONS | | | | | |
| Output Voltage High (V _{OH}) | I _{OH} = 2 mA @ 3.3 V, 0.85 mA @ 1.8 V | 0.8 × IOVDD | | | V |
| Output Voltage Low (V _{OL}) | I _{OL} = 2 mA @ 3.3 V, 0.85 mA @ 1.8 V | 0.1 × IOVDD | | | V |

DIGITAL TIMING SPECIFICATIONS-40°C < T_A < +85°C, IOVDD = 3.3 V ± 10%.**Table 7. Digital Timing**

| Parameter | Limit | | Unit | Description |
|----------------------------|------------------|------------------|------|---|
| | t _{MIN} | t _{MAX} | | |
| MASTER CLOCK | | | | |
| t _{MP} | 74 | 488 | ns | MCLK period, 256 × f _s mode. |
| t _{MP} | 37 | 244 | ns | MCLK period, 512 × f _s mode. |
| t _{MP} | 24.7 | 162.7 | ns | MCLK period, 768 × f _s mode. |
| t _{MP} | 18.5 | 122 | ns | MCLK period, 1024 × f _s mode. |
| SERIAL PORT | | | | |
| t _{BIL} | 5 | | ns | BCLK pulse width low. |
| t _{BIH} | 5 | | ns | BCLK pulse width high. |
| t _{LIS} | 5 | | ns | LRCLK setup. Time to BCLK rising. |
| t _{LIH} | 5 | | ns | LRCLK hold. Time from BCLK rising. |
| t _{SIS} | 5 | | ns | DAC_SDATA setup. Time to BCLK rising. |
| t _{SIH} | 5 | | ns | DAC_SDATA hold. Time from BCLK rising. |
| t _{SOD} | | 50 | ns | ADC_SDATA delay. Time from BCLK falling in master or slave mode. Full range of IOVDD. |
| | | 25 | ns | ADC_SDATA delay. Time from BCLK falling in master or slave mode. IOVDD = 3.3V ± 10%. |
| SPI PORT | | | | |
| f _{CCLK} | | 10 | MHz | CCLK frequency. |
| t _{CCPL} | 10 | | ns | CCLK pulse width low. |
| t _{CCPH} | 10 | | ns | CCLK pulse width high. |
| t _{CLS} | 5 | | ns | CLATCH setup. Time to CCLK rising. |
| t _{CLH} | 10 | | ns | CLATCH hold. Time from CCLK rising. |
| t _{CLPH} | 10 | | ns | CLATCH pulse width high. |
| t _{CDS} | 5 | | ns | CDATA setup. Time to CCLK rising. |
| t _{CDH} | 5 | | ns | CDATA hold. Time from CCLK rising. |
| t _{COD} | | 50 | ns | COU _T three-stated. Time from CLATCH rising. |
| I²C PORT | | | | |
| f _{SCL} | | 400 | kHz | SCL frequency. |
| t _{SCLH} | 0.6 | | μs | SCL high. |
| t _{SCLL} | 1.3 | | μs | SCL low. |
| t _{SCS} | 0.6 | | μs | Setup time; relevant for repeated start condition. |
| t _{SCH} | 0.6 | | μs | Hold time. After this period, the first clock is generated. |
| t _{DS} | 100 | | ns | Data setup time. |
| t _{SCR} | | 300 | ns | SCL rise time. |
| t _{SCF} | | 300 | ns | SCL fall time. |
| t _{SDR} | | 300 | ns | SDA rise time. |
| t _{SDF} | | 300 | ns | SDA fall time. |
| t _{BFT} | 0.6 | | μs | Bus-free time. Time between stop and start. |
| DIGITAL MICROPHONE | | | | |
| t _{DCF} | | 10 | ns | R _{LOAD} = 1 MΩ, C _{LOAD} = 14 pF. Digital microphone clock fall time. |
| t _{DCR} | | 10 | ns | Digital microphone clock rise time. |
| t _{DDV} | 22 | 30 | ns | Digital microphone delay time for valid data. |
| t _{DDH} | 0 | 12 | ns | Digital microphone delay time for data three-stated. |

DIGITAL TIMING DIAGRAMS

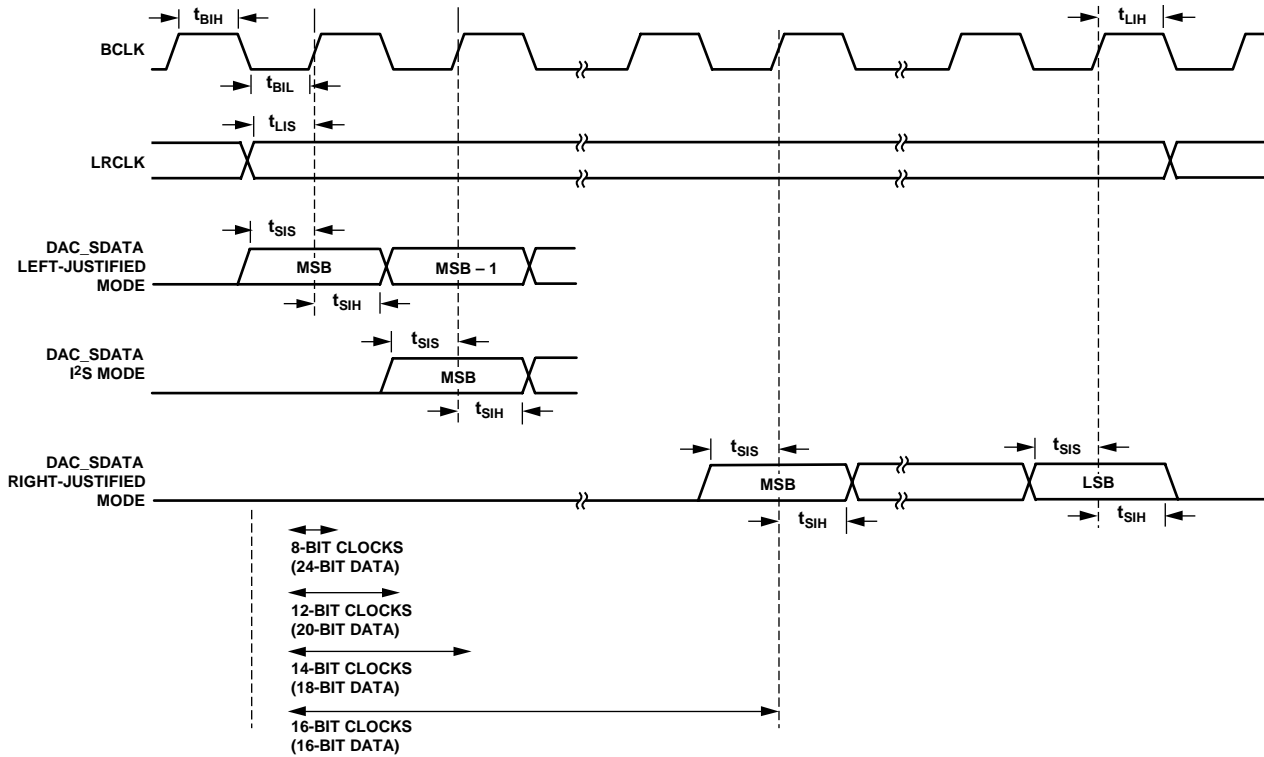

Figure 2. Serial Input Port Timing

07860-002

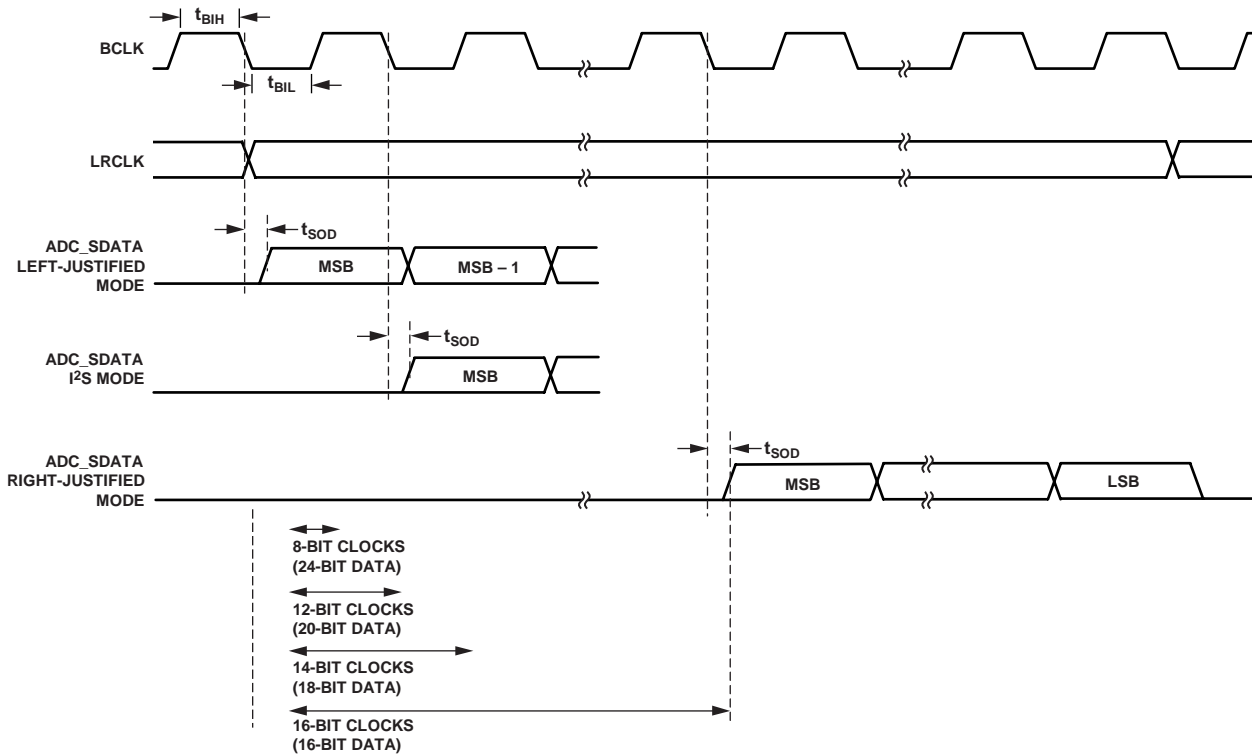

Figure 3. Serial Output Port Timing

07860-003

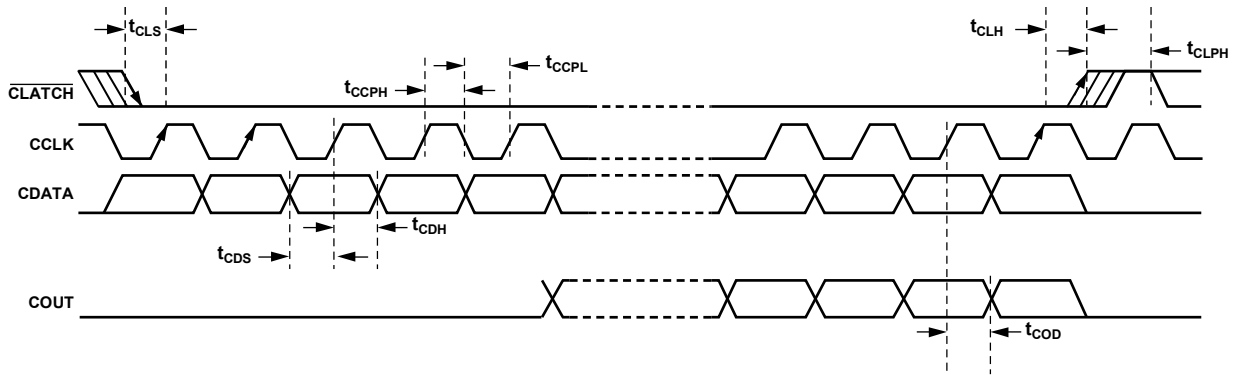

Figure 4. SPI Port Timing

07680-004

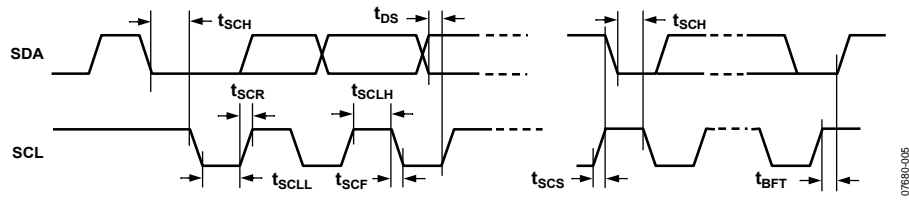

Figure 5. I²C Port Timing

07680-005

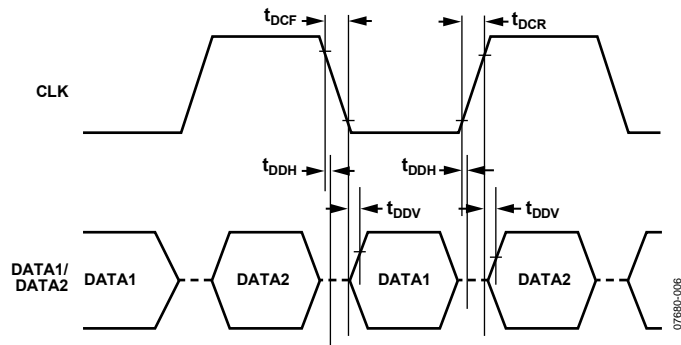

Figure 6. Digital Microphone Timing

07680-006

ABSOLUTE MAXIMUM RATINGS

Table 8.

| Parameter | Rating |
|-------------------------------------|-------------------------|
| Power Supply (AVDD) | -0.3 V to +3.65 V |
| Input Current (Except Supply Pins) | ±20 mA |
| Analog Input Voltage (Signal Pins) | -0.3 V to AVDD + 0.3 V |
| Digital Input Voltage (Signal Pins) | -0.3 V to IOVDD + 0.3 V |
| Operating Temperature Range | -40°C to +85°C |
| Storage Temperature Range | -65°C to +150°C |

Stresses at or above those listed under Absolute Maximum Ratings may cause permanent damage to the product. This is a stress rating only; functional operation of the product at these or any other conditions above those indicated in the operational section of this specification is not implied. Operation beyond the maximum operating conditions for extended periods may affect product reliability.

THERMAL RESISTANCE

θ_{JA} represents thermal resistance, junction-to-ambient; θ_{JC} represents thermal resistance, junction-to-case. All characteristics are for a 4-layer board.

Table 9. Thermal Resistance

| Package Type | θ_{JA} | θ_{JC} | Unit |
|---------------|---------------|---------------|------|
| 32-Lead LFCSP | 50.1 | 17 | °C/W |

ESD CAUTION



ESD (electrostatic discharge) sensitive device. Charged devices and circuit boards can discharge without detection. Although this product features patented or proprietary protection circuitry, damage may occur on devices subjected to high energy ESD. Therefore, proper ESD precautions should be taken to avoid performance degradation or loss of functionality.

PIN CONFIGURATION AND FUNCTION DESCRIPTIONS

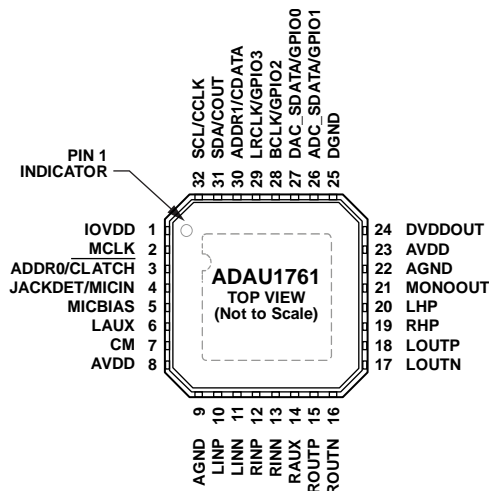

NOTES

1. THE EXPOSED PAD IS CONNECTED INTERNALLY TO THE ADAU1761 GROUNDS. FOR INCREASED RELIABILITY OF THE SOLDER JOINTS AND MAXIMUM THERMAL CAPABILITY, IT IS RECOMMENDED THAT THE PAD BE SOLDERED TO THE GROUND PLANE.

07980-007

Figure 7. Pin Configuration

Table 10. Pin Function Descriptions

| Pin No. | Mnemonic | Type ¹ | Description |
|---------|---------------|-------------------|---|
| 1 | IOVDD | PWR | Supply for Digital Input and Output Pins. The digital output pins are supplied from IOVDD, which also sets the highest input voltage that should be seen on the digital input pins. IOVDD should be set between 1.8 V and 3.3 V. The current draw of this pin is variable because it is dependent on the loads of the digital outputs. IOVDD should be decoupled to DGND with a 100 nF capacitor and a 10 µF capacitor. |
| 2 | MCLK | D_IN | External Master Clock Input. |
| 3 | ADDR0/CLATCH | D_IN | I ² C Address Bit 0 (ADDR0). SPI Latch Signal (CLATCH). Must go low at the beginning of an SPI transaction and high at the end of a transaction. Each SPI transaction can take a different number of CCLKs to complete, depending on the address and read/write bit that are sent at the beginning of the SPI transaction. |
| 4 | JACKDET/MICIN | D_IN | Detect Insertion/Removal of Headphone Plug (JACKDET). Digital Microphone Stereo Input (MICIN). |
| 5 | MICBIAS | A_OUT | Bias Voltage for Electret Microphone. |
| 6 | LAUX | A_IN | Left Channel Single-Ended Auxiliary Input. Biased at AVDD/2. |
| 7 | CM | A_OUT | AVDD/2 V Common-Mode Reference. A 10 µF to 47 µF standard decoupling capacitor should be connected between this pin and AGND to reduce crosstalk between the ADCs and DACs. This pin can be used to bias external analog circuits, as long as they are not drawing current from CM (for example, the noninverting input of an op amp). |
| 8 | AVDD | PWR | 1.8 V to 3.65 V Analog Supply for DAC and Microphone Bias. This pin should be decoupled locally to AGND with a 100 nF capacitor. |
| 9 | AGND | PWR | Analog Ground. The AGND and DGND pins can be tied together on a common ground plane. AGND should be decoupled locally to AVDD with a 100 nF capacitor. |
| 10 | LINP | A_IN | Left Channel Noninverting Input or Single-Ended Input 0. Biased at AVDD/2. |
| 11 | LINN | A_IN | Left Channel Inverting Input or Single-Ended Input 1. Biased at AVDD/2. |
| 12 | RINP | A_IN | Right Channel Noninverting Input or Single-Ended Input 2. Biased at AVDD/2. |
| 13 | RINN | A_IN | Right Channel Inverting Input or Single-Ended Input 3. Biased at AVDD/2. |
| 14 | RAUX | A_IN | Right Channel Single-Ended Auxiliary Input. Biased at AVDD/2. |
| 15 | ROUTP | A_OUT | Right Line Output, Positive. Biased at AVDD/2. |
| 16 | ROUTN | A_OUT | Right Line Output, Negative. Biased at AVDD/2. |
| 17 | LOUTN | A_OUT | Left Line Output, Negative. Biased at AVDD/2. |
| 18 | LOUTP | A_OUT | Left Line Output, Positive. Biased at AVDD/2. |

| Pin No. | Mnemonic | Type ¹ | Description |
|---------|-----------------|-------------------|--|
| 19 | RHP | A_OUT | Right Headphone Output. Biased at AVDD/2. |
| 20 | LHP | A_OUT | Left Headphone Output. Biased at AVDD/2. |
| 21 | MONOOUT | A_OUT | Mono Output or Virtual Ground for Capless Headphone. Biased at AVDD/2 when set as mono output. |
| 22 | AGND | PWR | Analog Ground. The AGND and DGND pins can be tied together on a common ground plane. AGND should be decoupled locally to AVDD with a 100 nF capacitor. |
| 23 | AVDD | PWR | 1.8 V to 3.3 V Analog Supply for ADC, Output Driver, and Input to Digital Supply Regulator. This pin should be decoupled locally to AGND with a 100 nF capacitor. |
| 24 | DVDDOUT | PWR | Digital Core Supply Decoupling Point. The digital supply is generated from an on-board regulator and does not require an external supply. DVDDOUT should be decoupled to DGND with a 100 nF capacitor and a 10 μ F capacitor. |
| 25 | DGND | PWR | Digital Ground. The AGND and DGND pins can be tied together on a common ground plane. DGND should be decoupled to DVDDOUT and to IOVDD with 100 nF capacitors and 10 μ F capacitors. |
| 26 | ADC_SDATA/GPIO1 | D_IO | ADC Serial Output Data (ADC_SDATA). General-Purpose Input/Output 1 (GPIO1). |
| 27 | DAC_SDATA/GPIO0 | D_IO | DAC Serial Input Data (DAC_SDATA). General-Purpose Input/Output 0 (GPIO0). |
| 28 | BCLK/GPIO2 | D_IO | Serial Data Port Bit Clock (BCLK). General-Purpose Input/Output 2 (GPIO2). |
| 29 | LRCLK/GPIO3 | D_IO | Serial Data Port Frame Clock (LRCLK). General-Purpose Input/Output 3 (GPIO3). |
| 30 | ADDR1/CDATA | D_IN | I ² C Address Bit 1 (ADDR1). SPI Data Input (CDATA). |
| 31 | SDA/COUT | D_IO | I ² C Data (SDA). This pin is a bidirectional open-collector input/output. The line connected to this pin should have a 2 k Ω pull-up resistor. SPI Data Output (COUT). This pin is used for reading back registers and memory locations. It is three-state when an SPI read is not active. |
| 32 | SCL/CCLK | D_IN | I ² C Clock (SCL). This pin is always an open-collector input when in I ² C control mode. The line connected to this pin should have a 2 k Ω pull-up resistor. SPI Clock (CCLK). This pin can run continuously or be gated off between SPI transactions. |
| EP | Exposed Pad | | Exposed Pad. The exposed pad is connected internally to the ADAU1761 grounds. For increased reliability of the solder joints and maximum thermal capability, it is recommended that the pad be soldered to the ground plane. See the Exposed Pad PCB Design section for more information. |

¹ A_IN = analog input, A_OUT = analog output, D_IN = digital input, D_IO = digital input/output, PWR = power.

TYPICAL PERFORMANCE CHARACTERISTICS

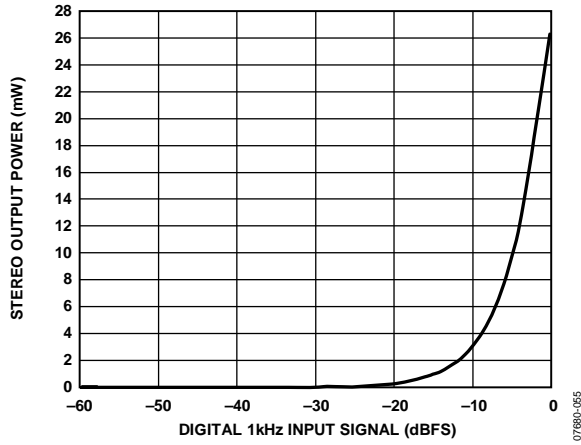

Figure 8. Headphone Amplifier Power vs. Input Level, 16 Ω Load

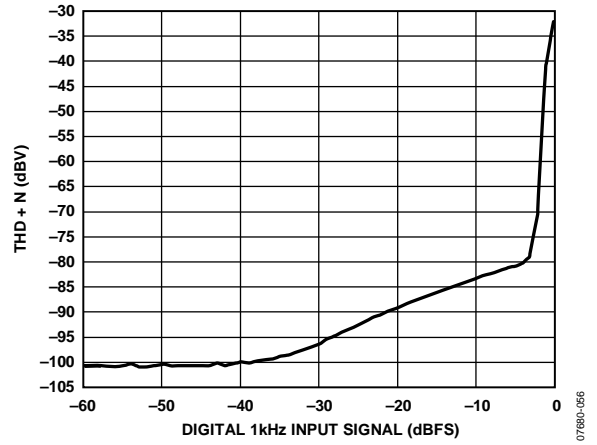

Figure 11. Headphone Amplifier THD + N vs. Input Level, 16 Ω Load

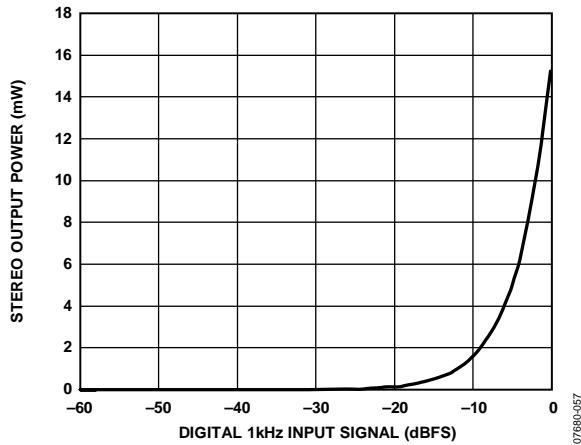

Figure 9. Headphone Amplifier Power vs. Input Level, 32 Ω Load

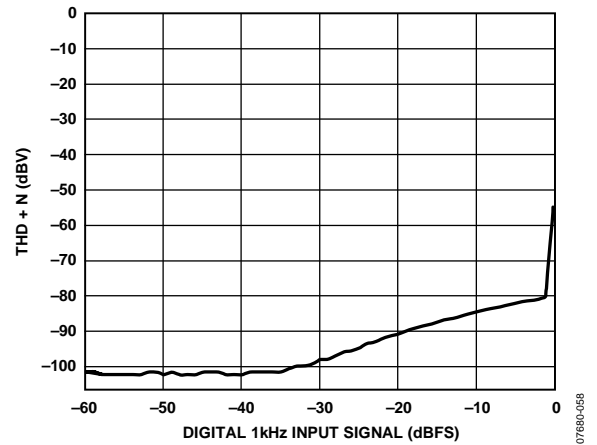

Figure 12. Headphone Amplifier THD + N vs. Input Level, 32 Ω Load

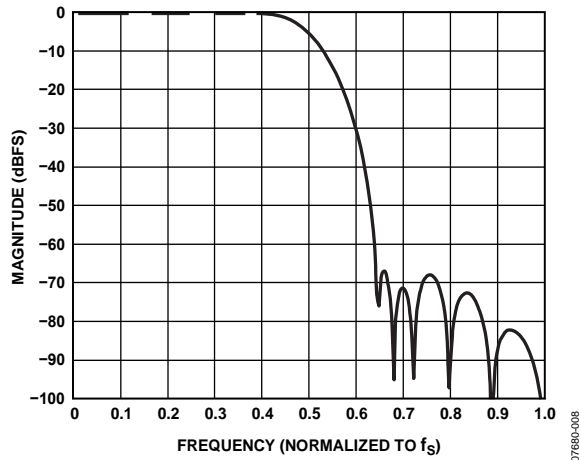

Figure 10. ADC Decimation Filter, 64× Oversampling, Normalized to f_s

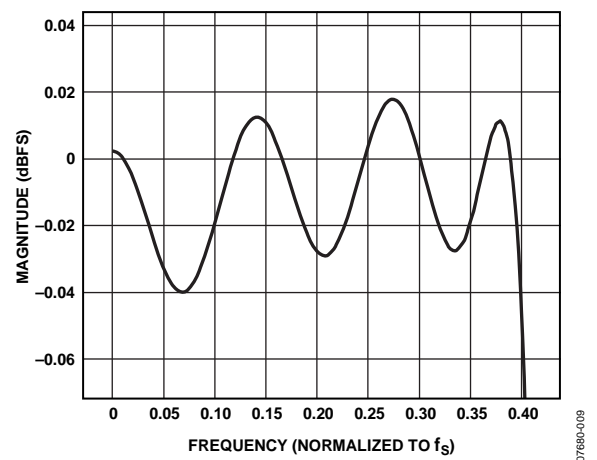

Figure 13. ADC Decimation Filter Pass-Band Ripple, 64× Oversampling, Normalized to f_s

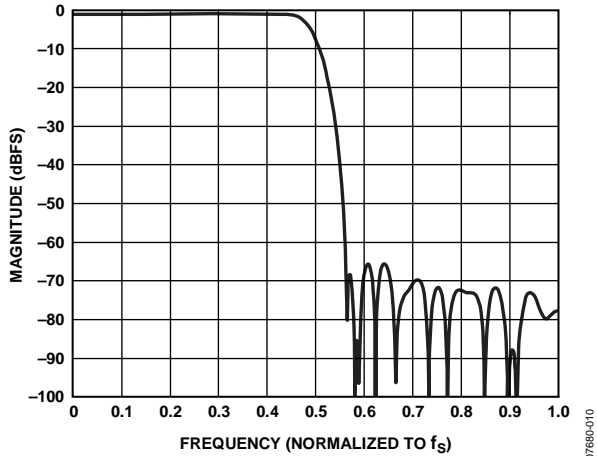

Figure 14. ADC Decimation Filter, 128x Oversampling, Normalized to f_s

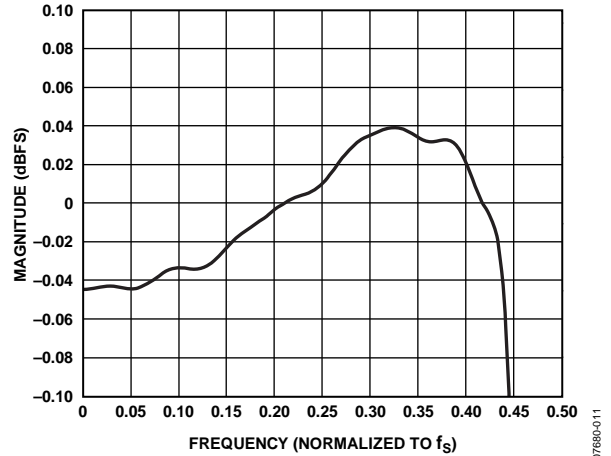

Figure 17. ADC Decimation Filter Pass-Band Ripple, 128x Oversampling, Normalized to f_s

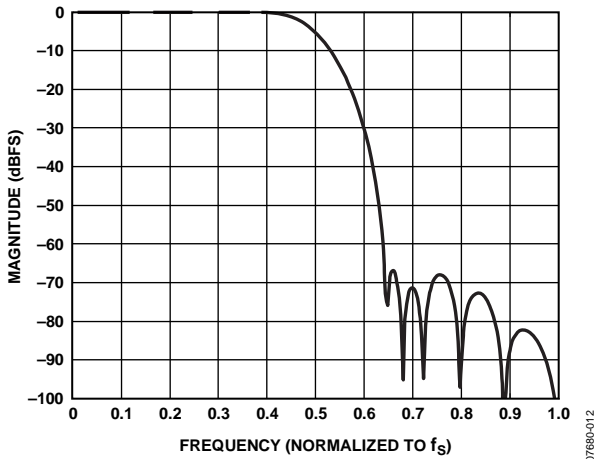

Figure 15. ADC Decimation Filter, 128x Oversampling, Double-Rate Mode, Normalized to f_s

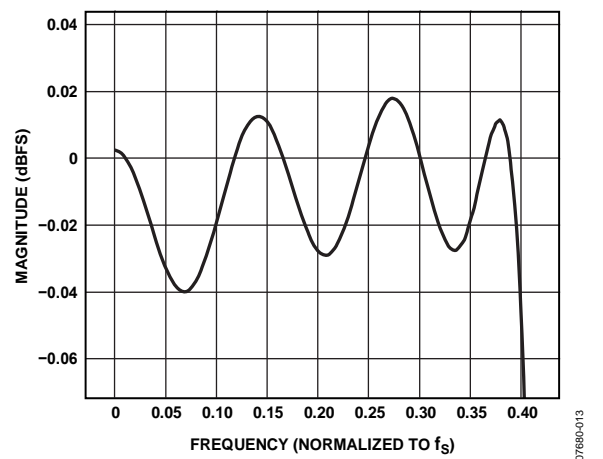

Figure 18. ADC Decimation Filter Pass-Band Ripple, 128x Oversampling, Double-Rate Mode, Normalized to f_s

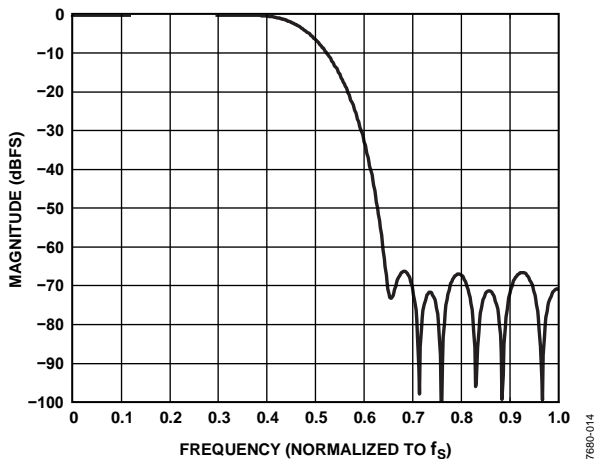

Figure 16. DAC Interpolation Filter, 64x Oversampling, Double-Rate Mode, Normalized to f_s

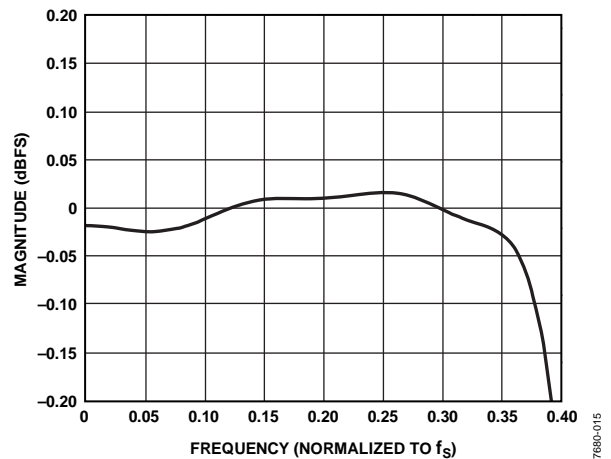

Figure 19. DAC Interpolation Filter Pass-Band Ripple, 64x Oversampling, Double-Rate Mode, Normalized to f_s

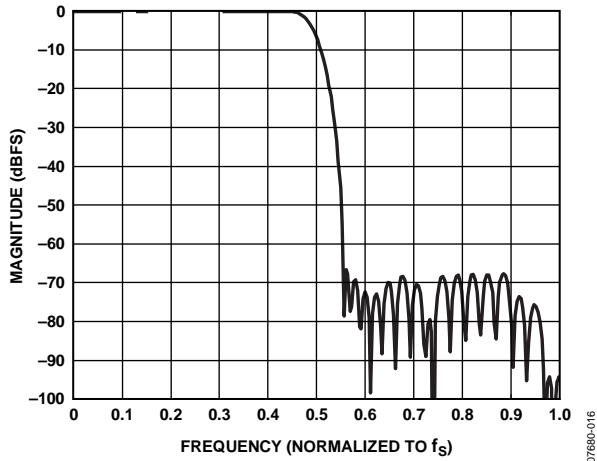

Figure 20. DAC Interpolation Filter, 128× Oversampling, Normalized to f_s

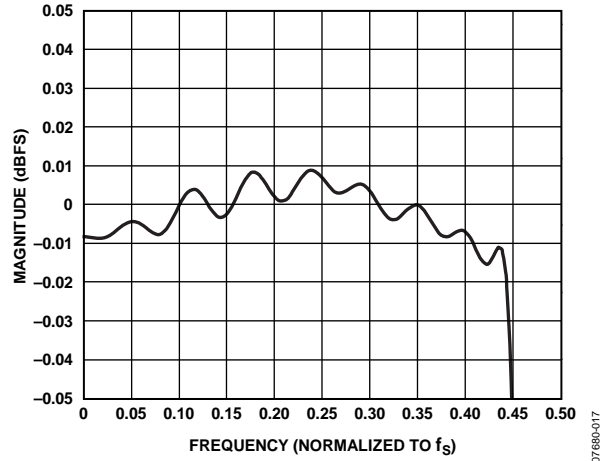

Figure 23. DAC Interpolation Filter Pass-Band Ripple, 128× Oversampling, Normalized to f_s

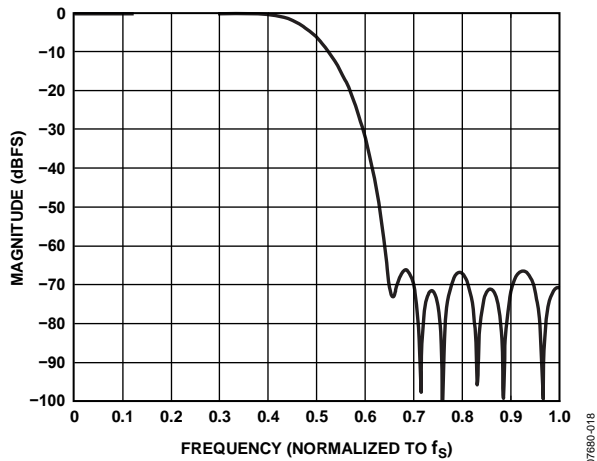

Figure 21. DAC Interpolation Filter, 128× Oversampling, Double-Rate Mode, Normalized to f_s

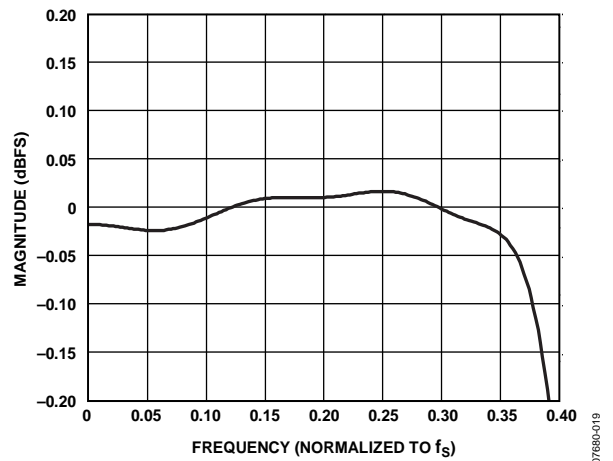

Figure 24. DAC Interpolation Filter Pass-Band Ripple, 128× Oversampling, Double-Rate Mode, Normalized to f_s

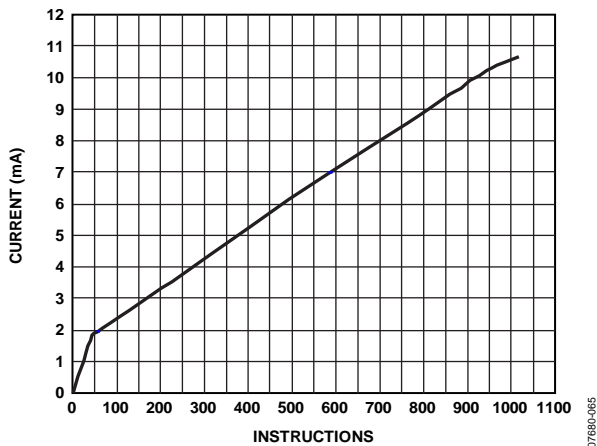

Figure 22. Typical DSP Current Draw

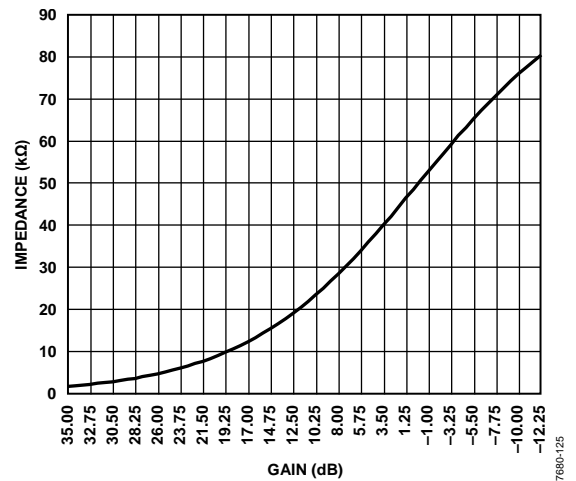

Figure 25. Input Impedance vs. Gain for Analog Inputs

SYSTEM BLOCK DIAGRAMS

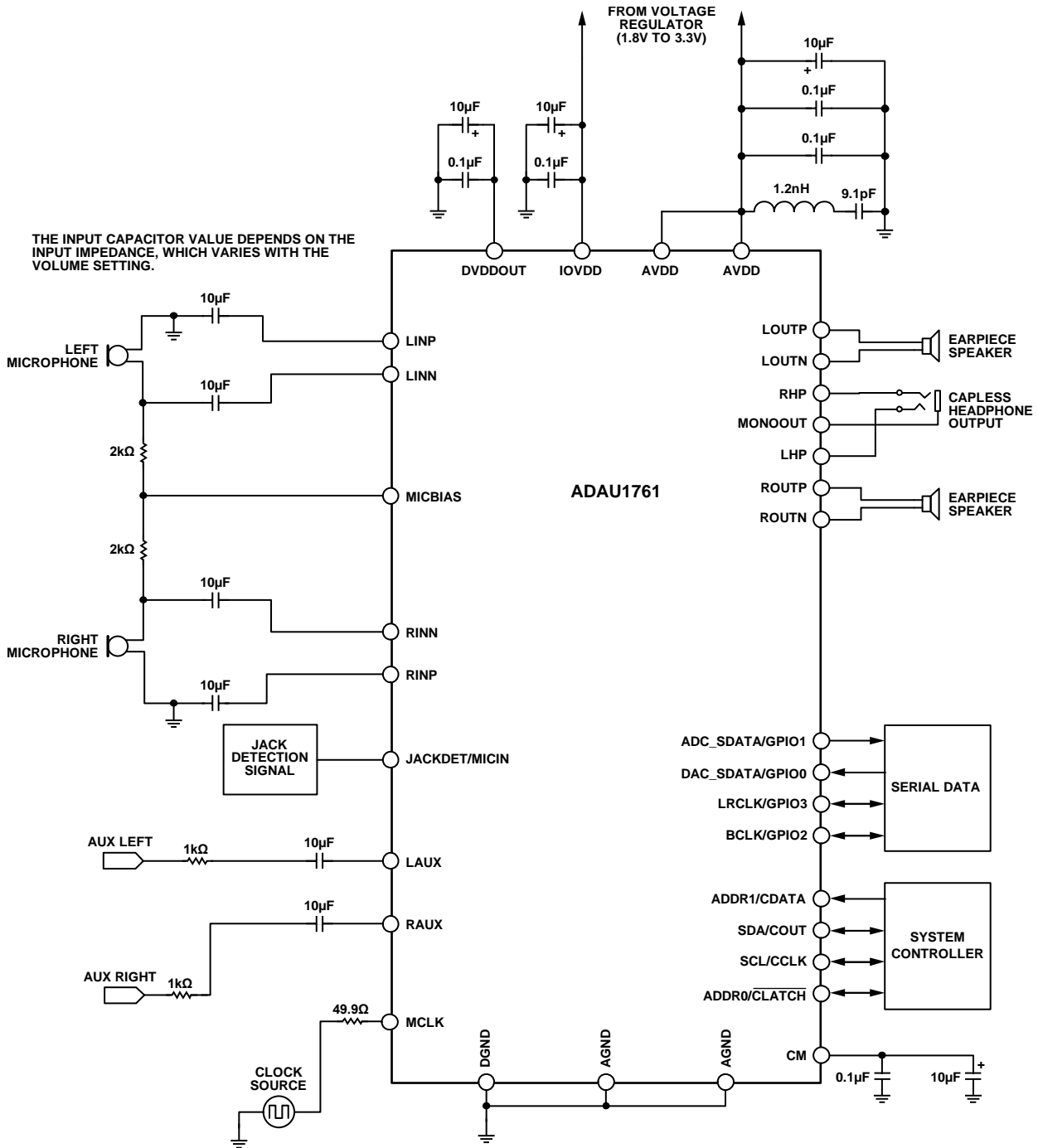

Figure 26. System Block Diagram

07680-045

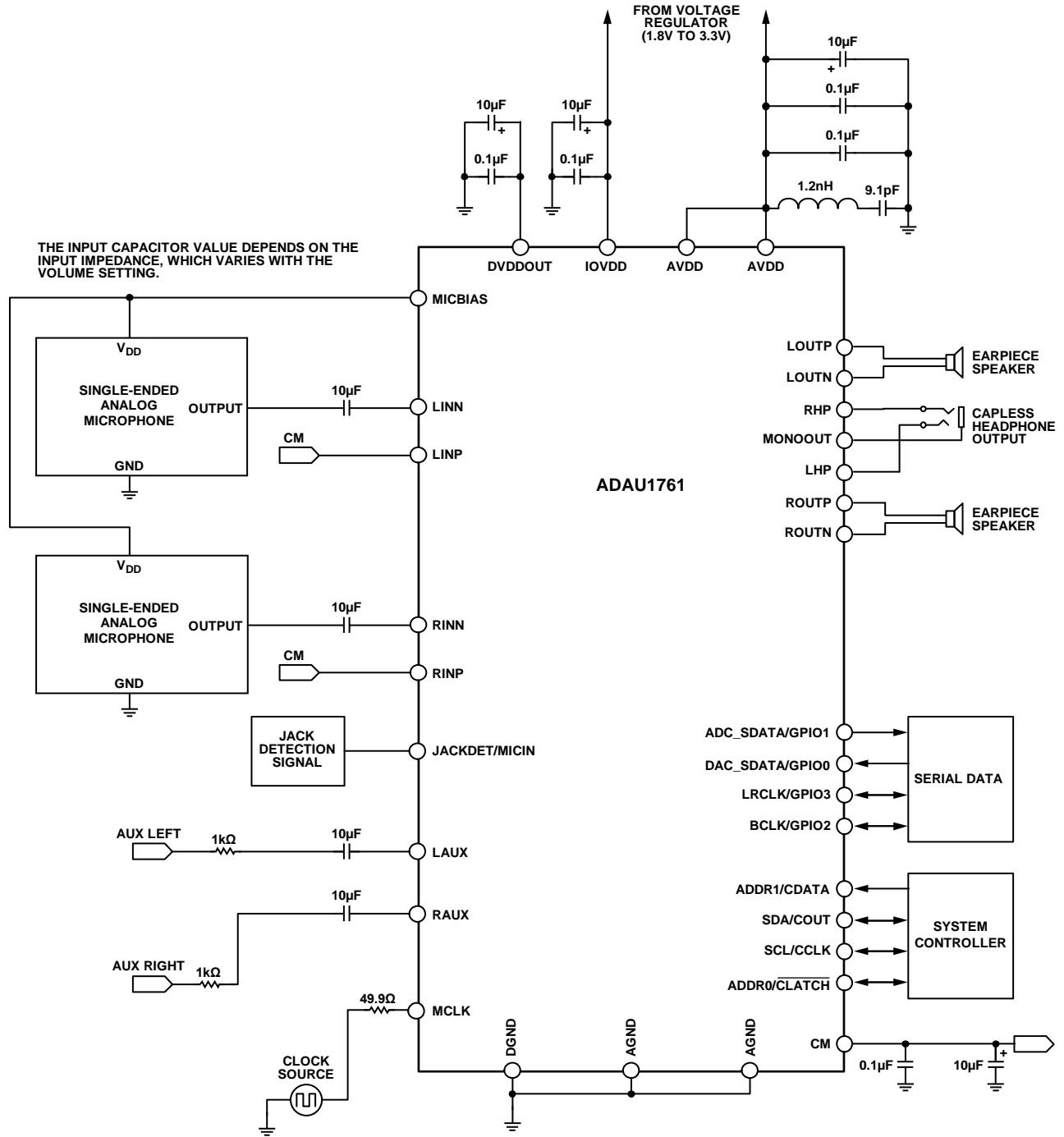

Figure 27. System Block Diagram with Analog Microphones

07689-059

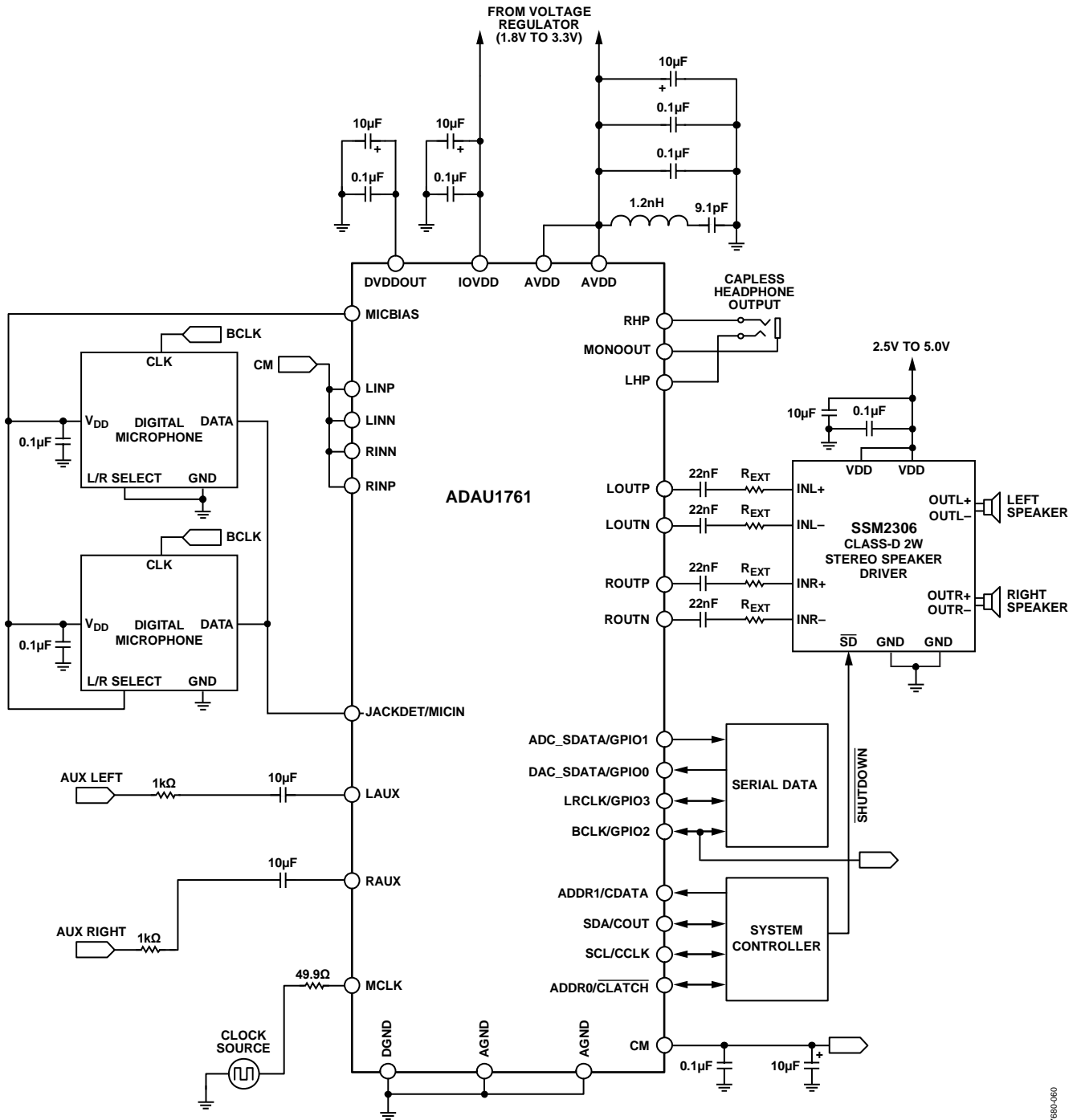

Figure 28. System Block Diagram with Digital Microphones and SSM2306 Class-D Speaker Driver

07680-960

THEORY OF OPERATION

The ADAU1761 is a low power audio codec with an integrated stream-oriented DSP core, making it an all-in-one package that offers high quality audio, low power, small size, and many advanced features. The stereo ADC and stereo DAC each have an SNR of at least +98 dB and a THD + N of at least -90 dB. The serial data port is compatible with I²S, left-justified, right-justified, and TDM modes for interfacing to digital audio data. The operating voltage range is 1.8 V to 3.65 V, with an on-board regulator generating the internal digital supply voltage.

The record signal path includes very flexible input configurations that can accept differential and single-ended analog microphone inputs as well as a digital microphone input. A microphone bias pin provides seamless interfacing to electret microphones. Input configurations can accept up to six single-ended analog signals or variations of stereo differential or stereo single-ended signals with two additional auxiliary single-ended inputs. Each input signal has its own programmable gain amplifier (PGA) for volume adjustment and can be routed directly to the playback path output mixers, bypassing the ADCs. An automatic level control (ALC) can also be implemented to keep the recording volume constant.

The ADCs and DACs are high quality, 24-bit Σ - Δ converters that operate at selectable 64 \times or 128 \times oversampling ratios. The base sampling rate of the converters is set by the input clock rate and can be further scaled with the converter control register settings. The converters can operate at sampling frequencies from 8 kHz to 96 kHz. The ADCs and DACs also include very fine-step digital volume controls.

The playback path allows input signals and DAC outputs to be mixed into various output configurations. Headphone drivers are available for a stereo headphone output, and the other output pins are capable of differentially driving an earpiece speaker. Capless headphone outputs are possible with the use of the mono output as a virtual ground connection. The stereo line outputs can be used as either single-ended or differential outputs and as an optional mix-down mono output.

The DSP core introduces many features that make this codec unique and optimized for audio processing. The program and parameter RAMs can be loaded with custom audio processing signal flow built using the SigmaStudio graphical programming software from Analog Devices, Inc. The values stored in the parameter RAM control individual signal processing blocks, such as equalization filters, dynamics processors, audio delays, and mixer levels.

The SigmaStudio software is used to program and control the SigmaDSP through the control port. Along with designing and tuning a signal flow, the tools can be used to configure all of the DSP registers. The SigmaStudio graphical interface allows anyone with digital or analog audio processing knowledge to easily design DSP signal flow and port it to a target application. At the same time, it provides enough flexibility and programmability for an experienced DSP programmer to have in-depth control of the design. In SigmaStudio, the user can connect graphical blocks (such as biquad filters, dynamics processors, mixers, and delays), compile the design, and load the program and parameter files into the ADAU1761 memory through the control port. Signal processing blocks available in the provided libraries include the following:

- Enhanced stereo capture
- Single- and double-precision biquad filters
- FIR filters
- Dynamics processors with peak or rms detection for mono and multichannel dynamics
- Mixers and splitters
- Tone and noise generators
- Fixed and variable gain
- Loudness
- Delay
- Stereo enhancement
- Dynamic bass boost
- Noise and tone sources
- Level detectors

Additional processing blocks are always being developed. Analog Devices also provides proprietary and third-party algorithms for applications such as matrix decoding, bass enhancement, and surround virtualizers. Contact Analog Devices (www.analog.com) for information about licensing these algorithms.

The ADAU1761 can generate its internal clocks from a wide range of input clocks by using the on-board fractional PLL. The PLL accepts inputs from 8 MHz to 27 MHz.

The ADAU1761 is provided in a small, 32-lead, 5 mm \times 5 mm LFCSP with an exposed bottom pad.

STARTUP, INITIALIZATION, AND POWER

This section describes the procedure for properly starting up the ADAU1761. The following sequence provides a high level approach to the proper initiation of the system.

1. Apply power to the ADAU1761.
2. Lock the PLL to the input clock (if using the PLL).
3. Enable the core clock.
4. Load the register settings.

See the Startup section for more information about the proper start-up sequence.

POWER-UP SEQUENCE

The ADAU1761 uses a power-on reset (POR) circuit to reset the registers upon power-up. The POR monitors the DVDDOUT pin and generates a reset signal whenever power is applied to the chip. During the reset, the ADAU1761 is set to the default values documented in the register map (see the Control Registers section). Typically, with a 10 μF capacitor on AVDD, the POR takes approximately 14 ms.

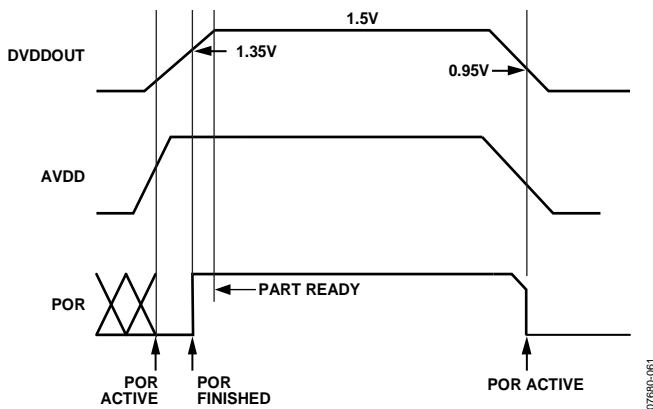

Figure 29. Power-On Reset Sequence

The PLL lock time is dependent on the MCLK rate. Typical lock times are provided in Table 11. The DSP can be enabled immediately after the PLL is locked.

Table 11. PLL Lock Times

| PLL Mode | MCLK Frequency | Lock Time (Typical) |
|------------|----------------|---------------------|
| Fractional | 8 MHz | 3.5 ms |
| Fractional | 12 MHz | 3.0 ms |
| Integer | 12.288 MHz | 2.96 ms |
| Fractional | 13 MHz | 2.4 ms |
| Fractional | 14.4 MHz | 2.4 ms |
| Fractional | 19.2 MHz | 2.98 ms |
| Fractional | 19.68 MHz | 2.98 ms |
| Fractional | 19.8 MHz | 2.98 ms |
| Fractional | 24 MHz | 2.95 ms |
| Integer | 24.576 MHz | 2.96 ms |
| Fractional | 26 MHz | 2.4 ms |
| Fractional | 27 MHz | 2.4 ms |

POWER REDUCTION MODES

Sections of the ADAU1761 chip can be turned on and off as needed to reduce power consumption. These include the ADCs, the DACs, the PLL, and the DSP core.

In addition, the control registers can be used to configure some functions for power saving, normal, or enhanced performance operation. See the Control Registers section for more information.

The digital filters of the ADCs and DACs can each be set to oversampling ratios of 64 \times or 128 \times (default). Setting the oversampling ratios to 64 \times for these filters lowers power consumption with a minimal impact on performance. See the Digital Filters section for specifications; see the Typical Performance Characteristics section for graphs of these filters.

DIGITAL POWER SUPPLY

The digital power supply for the ADAU1761 is generated from an internal regulator. This regulator generates a 1.5 V supply internally. The only external connection to this regulator is the DVDDOUT bypassing point. A 100 nF capacitor and a 10 μF capacitor should be connected between this pin and DGND.

INPUT/OUTPUT POWER SUPPLY

The power for the digital output pins is supplied from IOVDD, and this pin also sets the highest input voltage that should be seen on the digital input pins. IOVDD should be set between 1.8 V and 3.3 V; no digital input signal should be at a voltage level higher than the one on IOVDD. The current draw of this pin is variable because it depends on the loads of the digital outputs. IOVDD should be decoupled to DGND with a 100 nF capacitor and a 10 μF capacitor.

CLOCK GENERATION AND MANAGEMENT

The ADAU1761 uses a flexible clocking scheme that enables the use of many different input clock rates. The PLL can be bypassed or used, resulting in two different approaches to clock management. For more information about clocking schemes, PLL configuration, and sampling rates, see the Clocking and Sampling Rates section.

Case 1: PLL Is Bypassed

If the PLL is bypassed, the core clock is derived directly from the MCLK input. The rate of this clock must be set properly in Register R0 (clock control register, Address 0x4000) using the INFREQ[1:0] bits. When the PLL is bypassed, supported external clock rates are 256 $\times f_s$, 512 $\times f_s$, 768 $\times f_s$, and 1024 $\times f_s$, where f_s is the base sampling rate. The core clock of the chip is off until the core clock enable bit (COREN) is asserted. If a clock slower than 1024 $\times f_s$ is directly input to the ADAU1761 (bypassing the PLL), the number of available SigmaDSP processing cycles is reduced and the DSPSR bits in Register R57 (Address 0x40EB) should be adjusted accordingly.

Case 2: PLL Is Used

The core clock to the entire chip is off during the PLL lock acquisition period. The user can poll the lock bit to determine when the PLL has locked. After lock is acquired, the ADAU1761 can be started by asserting the core clock enable bit (COREN) in Register R0 (clock control register, Address 0x4000). This bit enables the core clock to all the internal blocks of the ADAU1761.

PLL Lock Acquisition

During the lock acquisition period, only Register R0 (Address 0x4000) and Register R1 (Address 0x4002) are accessible through the control port. Because all other registers require a valid master clock for reading and writing, do not attempt to access any other register. Any read or write is prohibited until the core clock enable bit (COREN) and the lock bit are both asserted.

To program the PLL during initialization or reconfiguration of the clock setting, the following procedure must be followed:

1. Power down the PLL.
2. Reset the PLL control register.
3. Start the PLL.
4. Poll the lock bit.
5. Assert the core clock enable bit after the PLL lock is acquired.

The PLL control register (Register R1, Address 0x4002) is a 48-bit register where all bits must be written with a single continuous write to the control port.

CLOCKING AND SAMPLING RATES

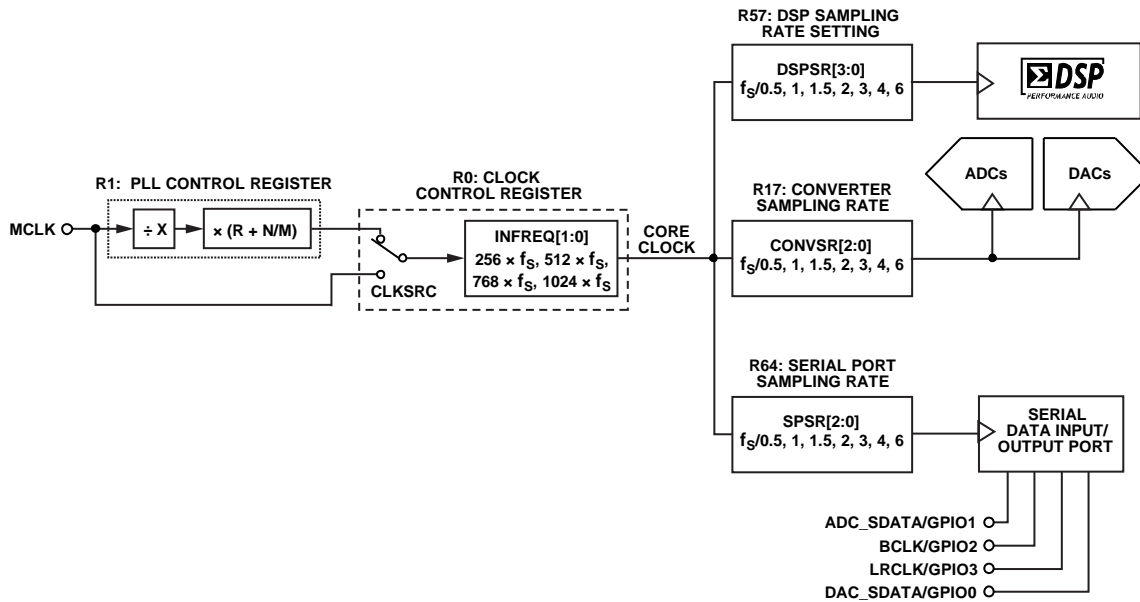

Figure 30. Clock Tree Diagram

CORE CLOCK

Clocks for the converters, the serial ports, and the DSP are derived from the core clock. The core clock can be derived directly from MCLK or it can be generated by the PLL. The CLKSRC bit (Bit 3 in Register R0, Address 0x4000) determines the clock source.

The INFREQ[1:0] bits should be set according to the expected input clock rate selected by CLKSRC; this value also determines the core clock rate and the base sampling frequency, f_s .

For example, if the input to CLKSRC = 49.152 MHz (from PLL), then

$$INFREQ[1:0] = 1024 \times f_s$$

$$f_s = 49.152 \text{ MHz} / 1024 = 48 \text{ kHz}$$

The PLL output clock rate is always $1024 \times f_s$, and the clock control register automatically sets the INFREQ[1:0] bits to $1024 \times f_s$ when using the PLL. When using a direct clock, the INFREQ[1:0] frequency should be set according to the MCLK pin clock rate and the desired base sampling frequency.

To utilize the maximum amount of DSP instructions, the core clock should run at a rate of $1024 \times f_s$.

Table 12. Clock Control Register (Register R0, Address 0x4000)

| Bits | Bit Name | Settings |
|-------|-------------|---|
| 3 | CLKSRC | 0: Direct from MCLK pin (default) 1: PLL clock |
| [2:1] | INFREQ[1:0] | 00: $256 \times f_s$ (default) 01: $512 \times f_s$ 10: $768 \times f_s$ 11: $1024 \times f_s$ |
| 0 | COREN | 0: Core clock disabled (default) 1: Core clock enabled |

SAMPLING RATES

The ADCs, DACs, and serial port share a common sampling rate that is set in Register R17 (Converter Control 0 register, Address 0x4017). The CONVSR[2:0] bits set the sampling rate as a ratio of the base sampling frequency. The DSP sampling rate is set in Register R57 (DSP sampling rate setting register, Address 0x40EB) using the DSPSR[3:0] bits, and the serial port sampling rate is set in Register R64 (serial port sampling rate register, Address 0x40F8) using the SPSR[2:0] bits.

It is recommended that the sampling rates for the converters, serial ports, and DSP be set to the same value, unless appropriate compensation filtering is done within the DSP. Table 13 and Table 14 list the sampling rate divisions for common base sampling rates.

Table 13. 48 kHz Base Sampling Rate Divisions

| Base Sampling Frequency | Sampling Rate Scaling | Sampling Rate |
|-------------------------|-----------------------|---------------|
| $f_s = 48 \text{ kHz}$ | $f_s/1$ | 48 kHz |
| | $f_s/6$ | 8 kHz |
| | $f_s/4$ | 12 kHz |
| | $f_s/3$ | 16 kHz |
| | $f_s/2$ | 24 kHz |
| | $f_s/1.5$ | 32 kHz |
| | $f_s/0.5$ | 96 kHz |

Table 14. 44.1 kHz Base Sampling Rate Divisions

| Base Sampling Frequency | Sampling Rate Scaling | Sampling Rate |
|--------------------------|-----------------------|---------------|
| $f_s = 44.1 \text{ kHz}$ | $f_s/1$ | 44.1 kHz |
| | $f_s/6$ | 7.35 kHz |
| | $f_s/4$ | 11.025 kHz |
| | $f_s/3$ | 14.7 kHz |
| | $f_s/2$ | 22.05 kHz |
| | $f_s/1.5$ | 29.4 kHz |
| | $f_s/0.5$ | 88.2 kHz |

Table 15. PLL Control Register (Register R1, Address 0x4002)

| Bits | Bit Name | Description |
|---------|----------|---|
| [47:32] | M[15:0] | Denominator of the fractional PLL: 16-bit binary number 0x00FD: M = 253 (default) |
| [31:16] | N[15:0] | Numerator of the fractional PLL: 16-bit binary number 0x000C: N = 12 (default) |
| [14:11] | R[3:0] | Integer part of PLL: four bits, only values 2 to 8 are valid 0010: R = 2 (default) 0011: R = 3 0100: R = 4 0101: R = 5 0110: R = 6 0111: R = 7 1000: R = 8 |

PLL

The PLL uses the MCLK as a reference to generate the core clock. PLL settings are set in Register R1 (PLL control register, Address 0x4002). Depending on the MCLK frequency, the PLL must be set for either integer or fractional mode. The PLL can accept input frequencies in the range of 8 MHz to 27 MHz.

All six bytes in the PLL control register must be written with a single continuous write to the control port.

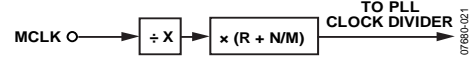

Figure 31. PLL Block Diagram

Integer Mode

Integer mode is used when the MCLK is an integer (R) multiple of the PLL output ($1024 \times f_s$).

For example, if MCLK = 12.288 MHz and $f_s = 48 \text{ kHz}$, then

$$PLL \text{ required output} = 1024 \times 48 \text{ kHz} = 49.152 \text{ MHz}$$

$$R = 49.152 \text{ MHz} / 12.288 \text{ MHz} = 4$$

In integer mode, the values set for N and M are ignored.

Fractional Mode

Fractional mode is used when the MCLK is a fractional ($R + (N/M)$) multiple of the PLL output.

For example, if MCLK = 12 MHz and $f_s = 48 \text{ kHz}$, then

$$PLL \text{ required output} = 1024 \times 48 \text{ kHz} = 49.152 \text{ MHz}$$

$$R + (N/M) = 49.152 \text{ MHz} / 12 \text{ MHz} = 4 + (12/125)$$

Common fractional PLL parameter settings for 44.1 kHz and 48 kHz sampling rates can be found in Table 16 and Table 17.

The PLL outputs a clock in the range of 41 MHz to 54 MHz, which should be taken into account when calculating PLL values and MCLK frequencies.

| Bits | Bit Name | Description |
|--------|----------|---|
| [10:9] | X[1:0] | PLL input clock divider 00: X = 1 (default) 01: X = 2 10: X = 3 11: X = 4 |
| 8 | Type | PLL operation mode 0: Integer (default) 1: Fractional |
| 1 | Lock | PLL lock (read-only bit) 0: PLL unlocked (default) 1: PLL locked |
| 0 | PLLEN | PLL enable 0: PLL disabled (default) 1: PLL enabled |

Table 16. Fractional PLL Parameter Settings for $f_s = 44.1$ kHz (PLL Output = 45.1584 MHz = 1024 × f_s)

| MCLK Input (MHz) | Input Divider (X) | Integer (R) | Denominator (M) | Numerator (N) | R2: PLL Control Setting (Hex) |
|------------------|-------------------|-------------|-----------------|---------------|-------------------------------|
| 8 | 1 | 5 | 625 | 403 | 0x0271 0193 2901 |
| 12 | 1 | 3 | 625 | 477 | 0x0271 01DD 1901 |
| 13 | 1 | 3 | 8125 | 3849 | 0x1FBD 0F09 1901 |
| 14.4 | 2 | 6 | 125 | 34 | 0x007D 0022 3301 |
| 19.2 | 2 | 4 | 125 | 88 | 0x007D 0058 2301 |
| 19.68 | 2 | 4 | 1025 | 604 | 0x0401 025C 2301 |
| 19.8 | 2 | 4 | 1375 | 772 | 0x055F 0304 2301 |
| 24 | 2 | 3 | 625 | 477 | 0x0271 01DD 1B01 |
| 26 | 2 | 3 | 8125 | 3849 | 0x1FBD 0F09 1B01 |
| 27 | 2 | 3 | 1875 | 647 | 0x0753 0287 1B01 |

Table 17. Fractional PLL Parameter Settings for $f_s = 48$ kHz (PLL Output = 49.152 MHz = 1024 × f_s)

| MCLK Input (MHz) | Input Divider (X) | Integer (R) | Denominator (M) | Numerator (N) | R2: PLL Control Setting (Hex) |
|------------------|-------------------|-------------|-----------------|---------------|-------------------------------|
| 8 | 1 | 6 | 125 | 18 | 0x007D 0012 3101 |
| 12 | 1 | 4 | 125 | 12 | 0x007D 000C 2101 |
| 13 | 1 | 3 | 1625 | 1269 | 0x0659 04F5 1901 |
| 14.4 | 2 | 6 | 75 | 62 | 0x004B 003E 3301 |
| 19.2 | 2 | 5 | 25 | 3 | 0x0019 0003 2B01 |
| 19.68 | 2 | 4 | 205 | 204 | 0x00CD 00CC 2301 |
| 19.8 | 2 | 4 | 825 | 796 | 0x0339 031C 2301 |
| 24 | 2 | 4 | 125 | 12 | 0x007D 000C 2301 |
| 26 | 2 | 3 | 1625 | 1269 | 0x0659 04F5 1B01 |
| 27 | 2 | 3 | 1125 | 721 | 0x0465 02D1 1B01 |

Table 18. Integer PLL Parameter Settings for $f_s = 48$ kHz (PLL Output = 49.152 MHz = 1024 × f_s)

| MCLK Input (MHz) | Input Divider (X) | Integer (R) | Denominator (M) | Numerator (N) | R2: PLL Control Setting (Hex) ¹ |
|------------------|-------------------|-------------|-----------------|---------------|--|
| 12.288 | 1 | 4 | Don't care | Don't care | 0xFFFF XXXX 2001 |
| 24.576 | 1 | 2 | Don't care | Don't care | 0xFFFF XXXX 1001 |

¹ X = don't care.

RECORD SIGNAL PATH

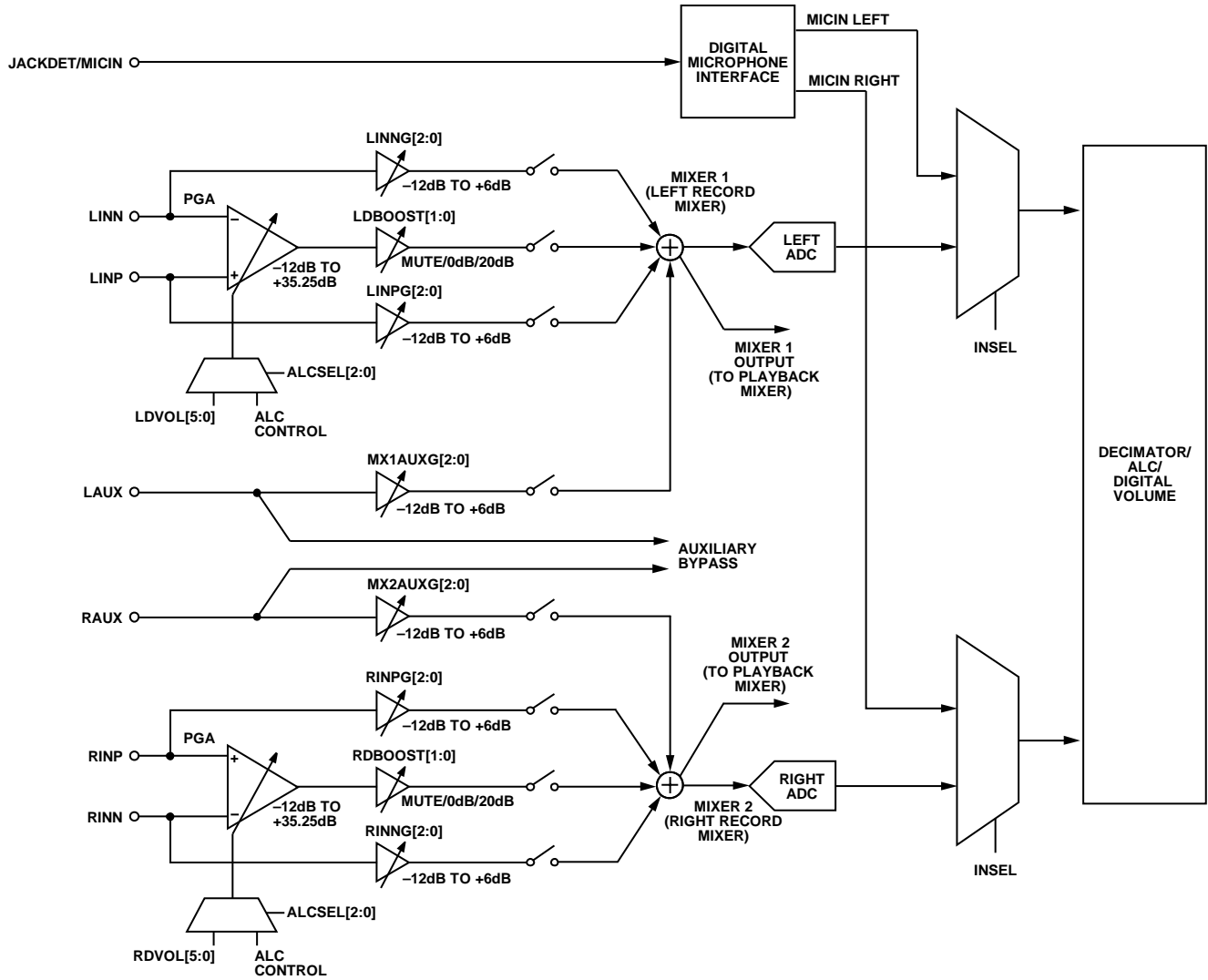

Figure 32. Record Signal Path

INPUT SIGNAL PATHS

The ADAU1761 can accept both line level and microphone inputs. The analog inputs can be configured in a single-ended or differential configuration. There is also an input for a digital microphone. The analog inputs are biased at AVDD/2. Unused input pins should be connected to CM.

Each of the six analog inputs has individual gain controls (boost or cut). The input signals are mixed and routed to an ADC. The mixed input signals can also bypass the ADCs and be routed directly to the playback mixers. Left channel inputs are mixed before the left ADC; however, it is possible to route the mixed analog signal around the ADC and output it into a left or right output channel. The same capabilities apply to the right channel and the right ADC.

Signals are inverted through the PGAs and the mixers. The result of this inversion is that differential signals input through the PGA are output from the ADCs at the same polarity as they are input. Single-ended inputs that pass through the mixer but not through the PGA are inverted. The ADCs are noninverting.

The input impedance of the analog inputs varies with the gain of the PGA. This impedance ranges from 1.7 kΩ at the 35.25 dB gain setting to 80.4 kΩ at the -12 dB setting. This range is shown in Figure 25.

Analog Microphone Inputs

For microphone inputs, configure the part in either stereo pseudo-differential mode or stereo full differential mode.

The LINN and LINP pins are the inverting and noninverting inputs for the left channel, respectively. The RINN and RINP pins are the inverting and noninverting inputs for the right channel, respectively.

For a differential microphone input, connect the positive signal to the noninverting input of the PGA and the negative signal to the inverting input of the PGA, as shown in Figure 33. The PGA settings are controlled with Register R8 (left differential input volume control register, Address 0x400E) and Register R9 (right differential input volume control register, Address 0x400F). The PGA must first be enabled by setting the RDEN and LDEN bits.

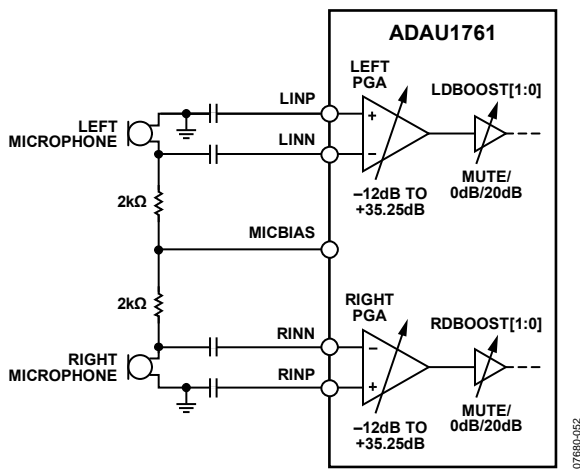

Figure 33. Stereo Differential Microphone Configuration

The PGA can also be used for single-ended microphone inputs. Connect LINP and/or RINP to the CM pin. In this configuration, the signal connects to the inverting input of the PGA, LINN and/or RINN, as shown in Figure 34.

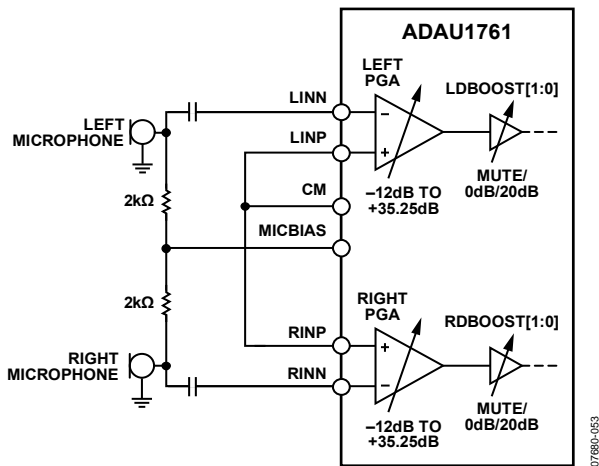

Figure 34. Stereo Single-Ended Microphone Configuration

Analog Line Inputs

Line input signals can be accepted by any analog input. It is possible to route signals on the RINN, RINP, LINN, and LINP pins around the differential amplifier to their own amplifier and to use these pins as single-ended line inputs by disabling the LDEN and RDEN bits (Bit 0 in Register R8, Address 0x400E, and Bit 0 in Register R9, Address 0x400F). Figure 35 depicts a stereo single-ended line input using the RINN and LINN pins.

The LAUX and RAUX pins are single-ended line inputs. They can be used together as a stereo single-ended auxiliary input, as shown in Figure 35. These inputs can bypass the input gain control, mixers, and ADCs to directly connect to the output playback mixers (see auxiliary bypass in Figure 32).

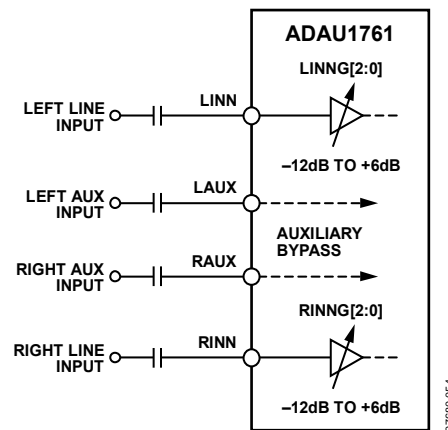

Figure 35. Stereo Single-Ended Line Input with Stereo Auxiliary Bypass

Digital Microphone Input

When using a digital microphone connected to the JACKDET/MICIN pin, the JDFUNC[1:0] bits in Register R2 (Address 0x4008) must be set to 10 to enable the microphone input and disable the jack detection function. The ADAU1761 must operate in master mode and source BCLK to the input clock of the digital microphone. The DSPRUN bit must also be asserted in Register R62 (DSP run register, Address 0x40F6) for digital microphone operation.

The digital microphone signal bypasses record path mixers and ADCs and is routed directly into the decimation filters. The digital microphone and ADCs share decimation filters and, therefore, both cannot be used simultaneously. The digital microphone input select bit, INSEL, can be set in Register R19 (ADC control register, Address 0x4019). Figure 36 depicts the digital microphone interface and signal routing.

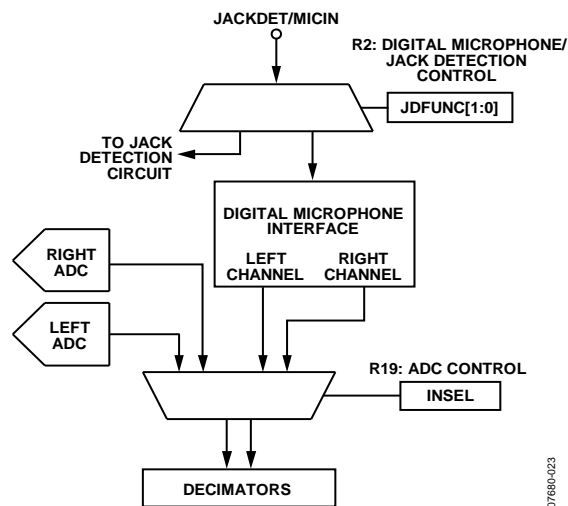

Figure 36. Digital Microphone Interface Block Diagram

Microphone Bias

The MICBIAS pin provides a voltage reference for electret analog microphones. The MICBIAS voltage is set in Register R10 (record microphone bias control register, Address 0x4010). In this register, the MICBIAS output can be enabled or disabled. Additional options include high performance operation and a gain boost. The gain boost provides two different voltage biases: $0.65 \times AVDD$ or $0.90 \times AVDD$. When enabled, the high performance bit increases supply current to the microphone bias circuit to decrease rms input noise.

The MICBIAS pin can also be used to cleanly supply voltage to digital microphones or analog microphones with separate power supply pins.

ANALOG-TO-DIGITAL CONVERTERS

The ADAU1761 uses two 24-bit Σ - Δ analog-to-digital converters (ADCs) with selectable oversampling ratios of $64\times$ or $128\times$ (selected by Bit 3 in Register R17, Address 0x4017).

ADC Full-Scale Level

The full-scale input to the ADCs (0 dBFS) depends on AVDD. At AVDD = 3.3 V, the full-scale input level is 1.0 V rms. This full-scale analog input will output a digital signal at -1.38 dBFS. This gain offset is built into the ADAU1761 to prevent clipping. The full-scale input level scales linearly with the level of AVDD.

For single-ended and pseudo-differential signals, the full-scale value corresponds to the signal level at the pins, 0 dBFS.

The full differential full-scale input level is measured after the differential amplifier, which corresponds to -6 dBFS at each pin.

Signal levels above the full-scale value cause the ADCs to clip.

Digital ADC Volume Control

The digital ADC volume can be attenuated before DSP processing using Register R20 (left input digital volume register, Address 0x401A) and Register R21 (right input digital volume register, Address 0x401B).

High-Pass Filter

By default, a high-pass filter is used in the ADC path to remove dc offsets; this filter can be enabled or disabled in Register R19 (ADC control register, Address 0x4019). At $f_s = 48$ kHz, the corner frequency of this high-pass filter is 2 Hz.

AUTOMATIC LEVEL CONTROL (ALC)

The ADAU1761 contains a hardware automatic level control (ALC). The ALC is designed to continuously adjust the PGA gain to keep the recording volume constant as the input level varies.

For optimal noise performance, the ALC uses the analog PGA to adjust the gain instead of using a digital method. This ensures that the ADC noise is not amplified at low signal levels. Extremely small gain step sizes are used to ensure high audio quality during gain changes.

To use the ALC function, the inputs must be applied either differentially or pseudo-differentially to input pins LINN and LINP, for the left channel, and RINN and RINP, for the right channel. The ALC function is not available for the auxiliary line input pins, LAUX and RAUX.

A block diagram of the ALC block is shown in Figure 37. The ALC logic receives the ADC output signals and analyzes these digital signals to set the PGA gain. The ALC control registers are used to control the time constants and output levels, as described in this section.

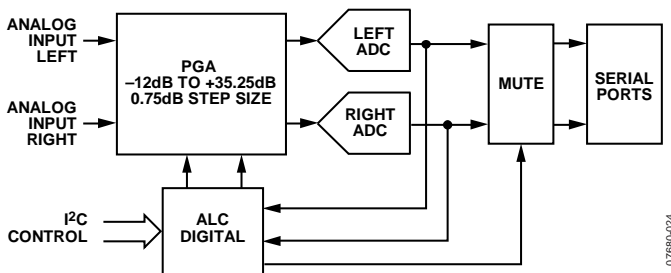

Figure 37. ALC Architecture

ALC PARAMETERS

The ALC function is controlled with the ALC control registers (Address 0x4011 through Address 0x4014) using the following parameters:

- **ALCSEL[2:0]:** The ALC select bits are used to enable the ALC and set the mode to left only, right only, stereo, or DSP. In stereo mode, the greater of the left or right inputs is used to calculate the gain, and the same gain is then applied to both the left and right channels. In DSP mode, the PGA gain is controlled by the SigmaDSP core.
- **ALCTARG[3:0]:** The ALC target is the desired input recording level that the ALC attempts to achieve.

- **ALCATCK[3:0]:** The ALC attack time sets how fast the ALC starts attenuating after a sudden increase in input level above the ALC target. Although it may seem that the attack time should be set as fast as possible to avoid clipping on transients, using a moderate value results in better overall sound quality. If the value is too fast, the ALC overreacts to very short transients, causing audible gain-pumping effects, which sounds worse than using a moderate value that allows brief periods of clipping on transients. A typical setting for music recording is 384 ms. A typical setting for voice recording is 24 ms.
- **ALCHOLD[3:0]:** These bits set the ALC hold time. When the output signal falls below the target output level, the gain is not increased unless the output remains below the target level for the period of time set by the hold time bits. The hold time is used to prevent the gain from modulating on a steady low frequency sine wave signal, which would cause distortion.
- **ALCDEC[3:0]:** The ALC decay time sets how fast the ALC increases the PGA gain after a sudden decrease in input level below the ALC target. A very slow setting can be used if the main function of the ALC is to set a music recording level. A faster setting can be used if the function of the ALC is to compress the dynamic range of a voice recording. Using a very fast decay time can cause audible artifacts such as noise pumping or distortion. A typical setting for music recording is 24.58 sec. A typical setting for voice recording is 1.54 sec.
- **ALCMAX[2:0]:** The maximum ALC gain bits are used to limit the maximum gain that can be programmed into the ALC. This can be used to prevent excessive noise in the recording for small input signals. Note that setting this register to a low value may prevent the ALC from reaching its target output level, but this behavior is often desirable to achieve the best overall sound.

Figure 38 shows the dynamic behavior of the PGA gain for a tone-burst input. The target output is achieved for three different input levels, with the effect of attack, hold, and decay shown in the figure. Note that for very small signals, the maximum PGA gain may prevent the ALC from achieving its target level; in the same way, for very large inputs, the minimum PGA gain may prevent the ALC from achieving its target level (assuming that the target output level is set to a very low value). The effects of the PGA gain limit are shown in the input/output graph of Figure 39.

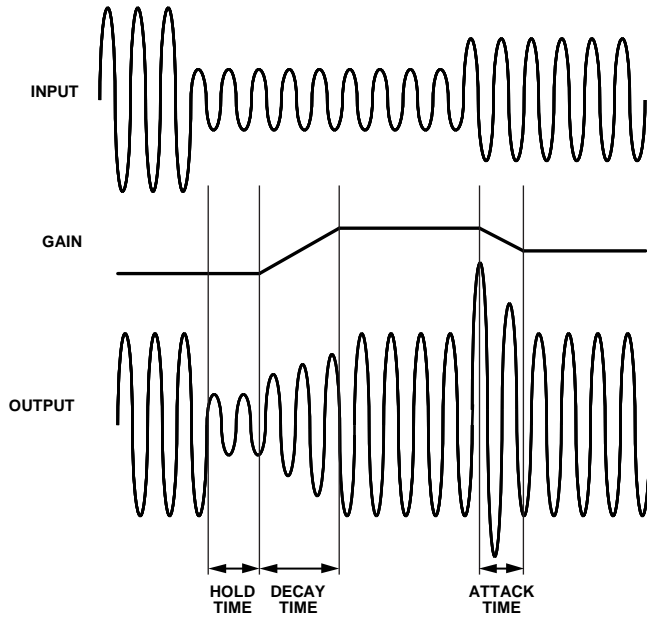

Figure 38. Basic ALC Operation

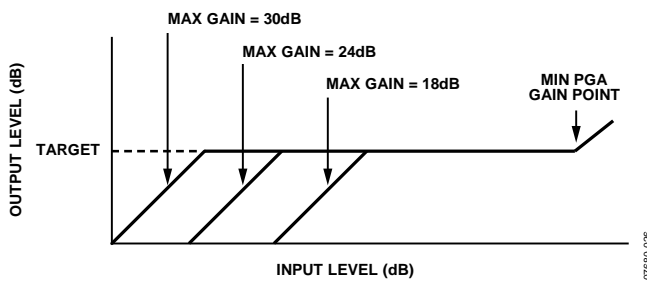

Figure 39. Effect of Varying the Maximum Gain Parameter

NOISE GATE FUNCTION

When using the ALC, one potential problem is that for small input signals, the PGA gain can become very large. A side effect of this is that the noise is amplified along with the signal of interest. To avoid this situation, the ADAU1761 noise gate can be used. The noise gate cuts off the ADC output when its signal level is below a set threshold. The noise gate is controlled using the following parameters in the ALC Control 3 register (Address 0x4014):

- NGTYP[1:0]: The noise gate type is set to one of four modes by writing to the NGTYP[1:0] bits.
- NGEN: The noise gate function is enabled by writing to the NGEN bit.
- NGTHR[4:0]: The threshold for muting the output is set by writing to the NGTHR[4:0] bits.

One common problem with noise gate functions is chatter, where a small signal that is close to the noise gate threshold varies in amplitude, causing the noise gate function to open and close rapidly. This causes an unpleasant sound.

To reduce this effect, the noise gate in the ADAU1761 uses a combination of a timeout period and hysteresis. The timeout period is set to 250 ms, so the signal must consistently be below

the threshold for 250 ms before the noise gate operates. Hysteresis is used so that the threshold for coming out of the mute state is 6 dB higher than the threshold for going into the mute state. There are four operating modes for the noise gate.

Noise Gate Mode 0 (see Figure 40) is selected by setting the NGTYP[1:0] bits to 00. In this mode, the current state of the PGA gain is held at its current state when the noise gate logic is activated. This prevents a large increase in background noise during periods of silence. When using this mode, it is advisable to use a relatively slow decay time. This is because the noise gate takes at least 250 ms to activate, and if the PGA gain has already increased to a large value during this time, the value at which the gain is held will be large.

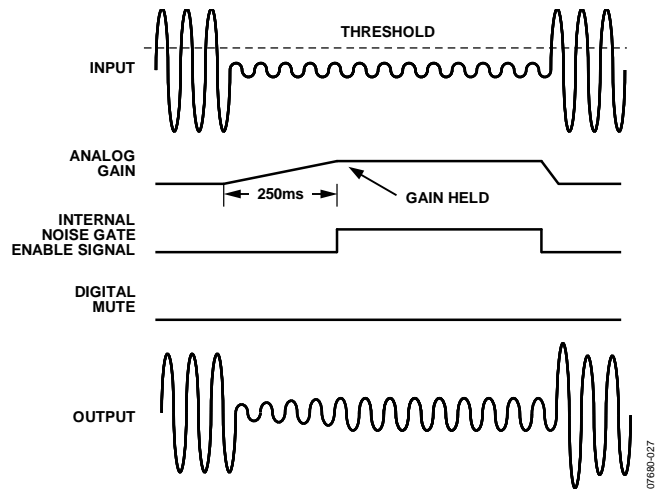

Figure 40. Noise Gate Mode 0 (PGA Gain Hold)

Noise Gate Mode 1 (see Figure 41) is selected by setting the NGTYP[1:0] bits to 01. In this mode, the ADAU1761 does a simple digital mute of the ADC output. Although this mode completely eliminates any background noise, the effect of an abrupt mute may not be pleasant to the ear.

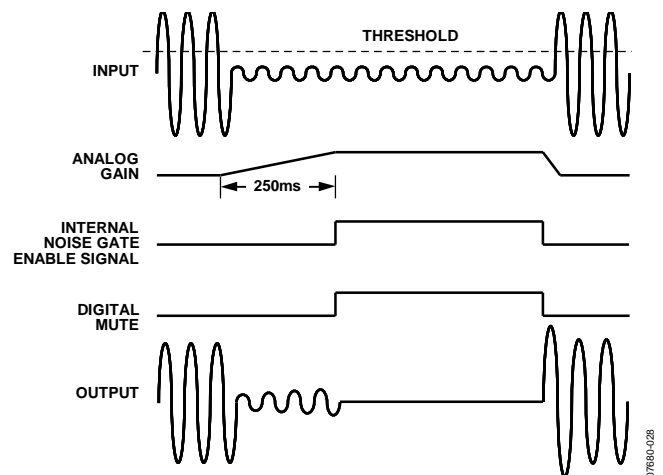

Figure 41. Noise Gate Mode 1 (Digital Mute)

Noise Gate Mode 2 (see Figure 42) is selected by setting the NGTYP[1:0] bits to 10. In this mode, the ADAU1761 improves the sound of the noise gate operation by first fading the PGA gain over a period of about 100 ms to the minimum PGA gain value. The ADAU1761 does not do a hard mute after the fade is complete, so some small background noise will still exist.

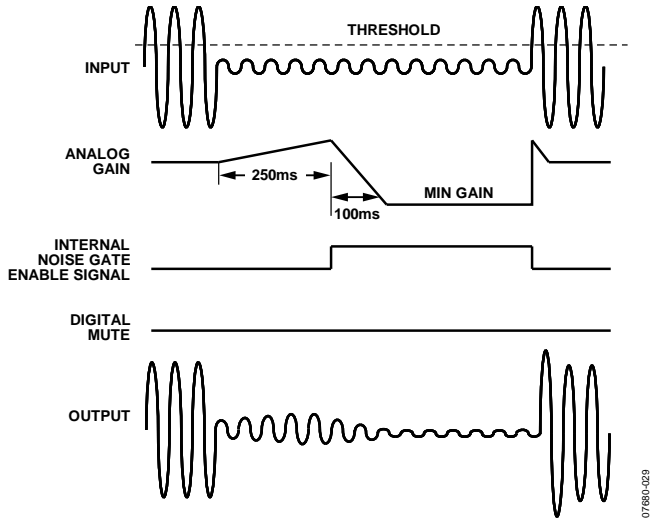

Figure 42. Noise Gate Mode 2 (Analog Fade)

07680-029

Noise Gate Mode 3 (see Figure 43) is selected by setting the NGTYP[1:0] bits to 11. This mode is the same as Mode 2 except that at the end of the PGA fade gain interval, a digital mute is performed. In general, this mode is the best-sounding mode, because the audible effect of the digital hard mute is reduced by the fact that the gain has already faded to a low level before the mute occurs.

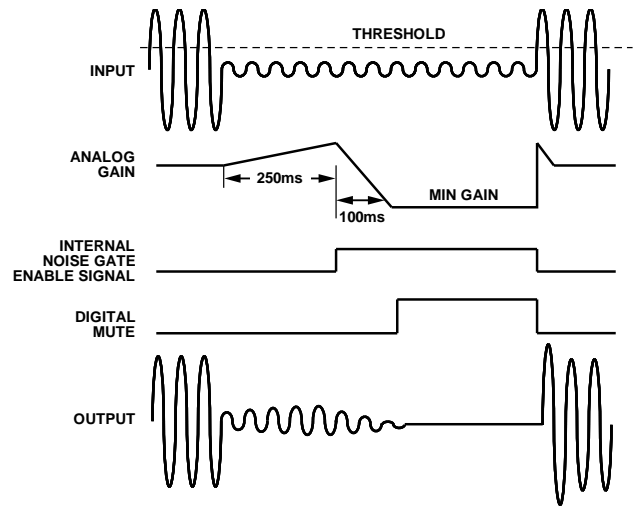

Figure 43. Noise Gate Mode 3 (Analog Fade/Digital Mute)

07680-030

PLAYBACK SIGNAL PATH

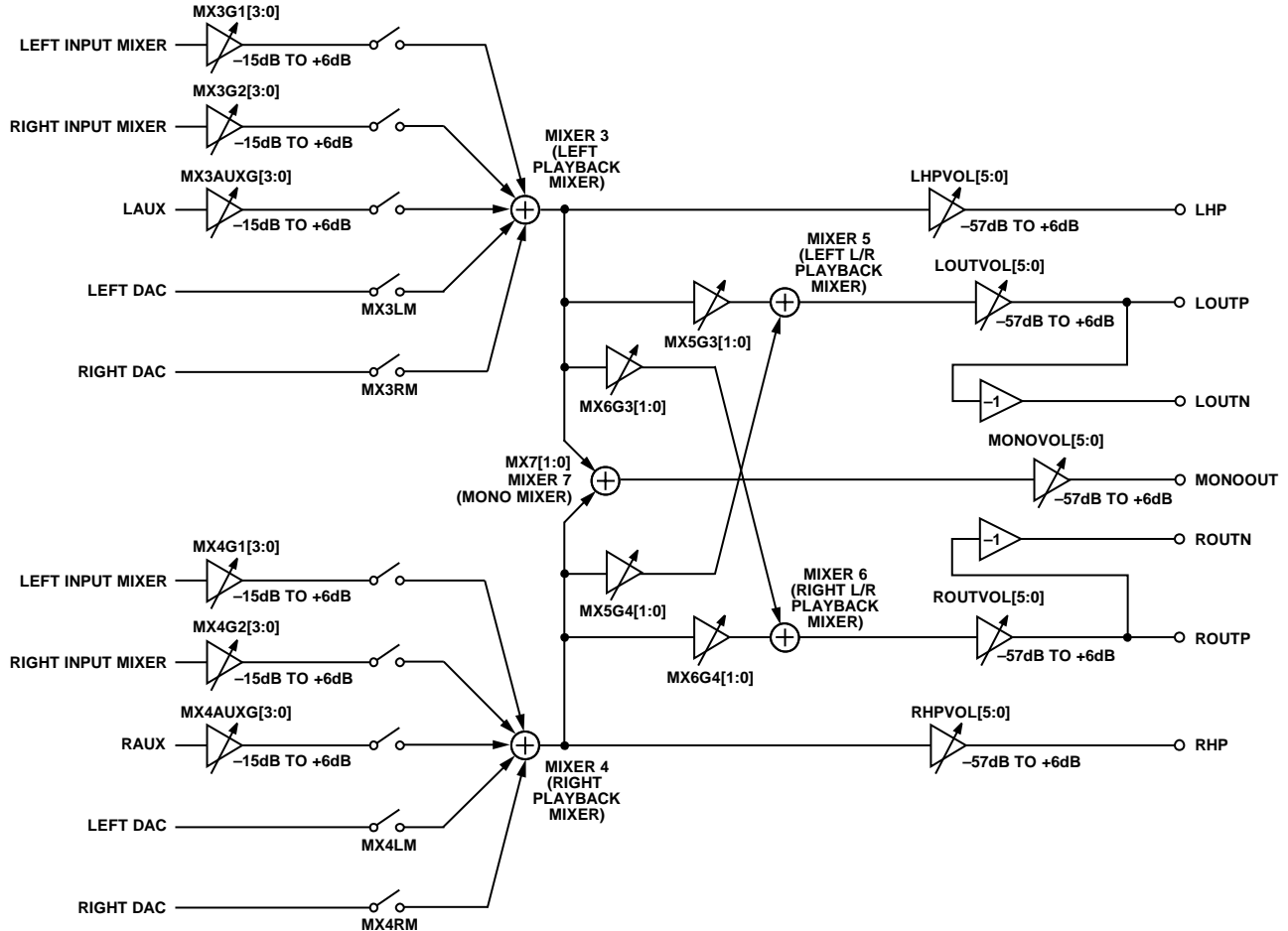

Figure 44. Playback Signal Path

OUTPUT SIGNAL PATHS

The outputs of the ADAU1761 can be configured as a variety of differential or single-ended outputs. All analog output pins are capable of driving headphone or earpiece speakers. There are selectable output paths for stereo signals or a downmixed mono output. The line outputs can drive a load of at least 10 k Ω or can be put into HP mode to drive headphones or earpiece speakers. The analog output pins are biased at $AVDD/2$.

With a 0 dBFS digital input and $AVDD = 1.8$ V, the full-scale output level is 500 mV rms; when $AVDD = 3.3$ V, the full-scale output level is 920 mV rms.

Signals are inverted through the mixers and volume controls. The result of this inversion is that the polarity of the differential outputs and the headphone outputs is preserved. The single-ended mono output is inverted. The DACs are noninverting.

Routing Flexibility

The playback path contains five mixers (Mixer 3 to Mixer 7) that perform the following functions:

- Mix signals from the record path and the DACs.
- Mix or swap the left and right channels.
- Mix a mono signal or generate a common-mode output.

Mixer 3 and Mixer 4 are dedicated to mixing signals from the record path and the DACs. Each of these two mixers can accept signals from the left and right DACs, the left and right input mixers, and the dedicated channel auxiliary input. Signals coming from the record path can be boosted or cut before the playback mixer.

For example, the MX4G2[3:0] bits set the gain from the output of Mixer 2 (right record channel) to the input of Mixer 4, hence the naming convention.

Signals coming from the DACs have digital volume attenuation controls set in Register R20 (left input digital volume register, Address 0x401A) and Register R21 (right input digital volume register, Address 0x401B).

HEADPHONE OUTPUT

The LHP and RHP pins can be driven by either a line output driver or a headphone driver by setting the HPMODE bit in Register R30 (playback headphone right volume control register, Address 0x4024). The headphone outputs can drive a load of at least 16 Ω.

Separate volume controls for the left and right channels range from -57 dB to +6 dB. Slew can be applied to all the playback volume controls using the ASLEW[1:0] bits in Register R34 (playback pop/click suppression register, Address 0x4028).

Capless Headphone Configuration

The headphone outputs can be configured in a capless output configuration with the MONOOUT pin used as a dc virtual ground reference. Figure 45 depicts a typical playback path in a capless headphone configuration. Table 19 lists the register settings for this configuration. As shown in this table, the MONOOUT pin outputs common mode (AVDD/2), which is used as the virtual headphone reference.

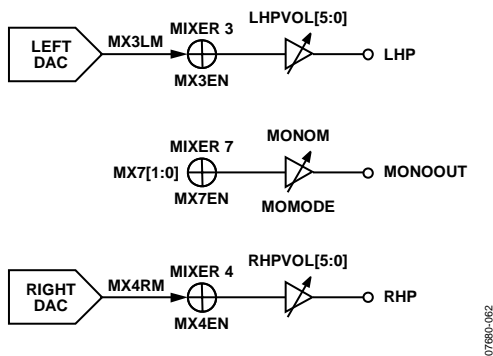

Figure 45. Capless Headphone Configuration Diagram

Table 19. Capless Headphone Register Settings

| Register | Bit Name | Setting |
|----------|-------------|-----------------------------------|
| R36 | DACEN[1:0] | 11 = both DACs on |
| R22 | MX3EN | 1 = enable Mixer 3 |
| | MX3LM | 1 = unmute left DAC input |
| R24 | MX4EN | 1 = enable Mixer 4 |
| | MX4RM | 1 = unmute right DAC input |
| R28 | MX7EN | 1 = enable Mixer 7 |
| | MX7[1:0] | 00 = common-mode output |
| R33 | MONOM | 1 = unmute mono output |
| | MOMODE | 1 = headphone output |
| R29 | LHPVOL[5:0] | Desired volume for LHP output |
| | LHPM | 1 = unmute left headphone output |
| R30 | HPMODE | 1 = headphone output |
| | RHPVOL[5:0] | Desired volume for RHP output |
| | RHPM | 1 = unmute right headphone output |

Headphone Output Power-Up/Power-Down Sequencing

To prevent pops when turning on the headphone outputs, the user must wait at least 4 ms to unmute these outputs after enabling the headphone output with the HPMODE bit. This is because of an internal capacitor that must charge before these outputs can be used. Figure 46 and Figure 47 illustrate the headphone power-up/power-down sequencing.

For capless headphones, configure the MONOOUT pin before unmuting the headphone outputs.

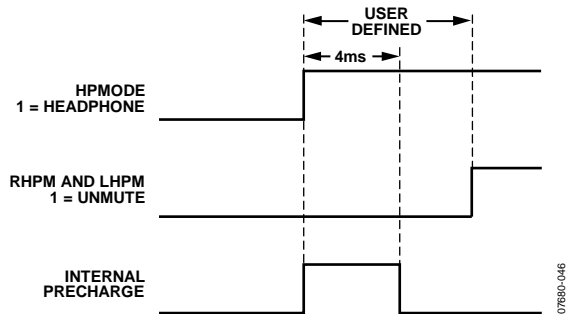

Figure 46. Headphone Output Power-Up Timing

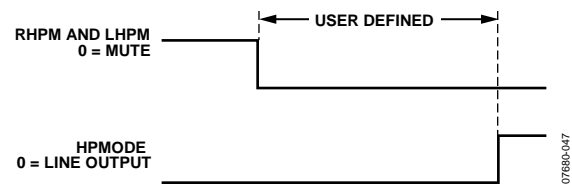

Figure 47. Headphone Output Power-Down Timing

Ground-Centered Headphone Configuration

The headphone outputs can also be configured as ground-centered outputs by placing coupling capacitors on the LHP and RHP pins. Ground-centered headphones should use the AGND pin as the ground reference.

When the headphone outputs are configured in this manner, the capacitors create a high-pass filter on the outputs. The corner frequency of this filter, at which point its attenuation is 3 dB, is calculated by the following formula:

$$f_{3dB} = 1/(2\pi \times R \times C)$$

where:

C is the capacitor value.

R is the impedance of the headphones.

For a typical headphone impedance of 16 Ω and a 47 μF capacitor, the corner frequency is 211 Hz.

Jack Detection

When the JACKDET/MICIN pin is set to the jack detect function, a flag on this pin can be used to mute the line outputs when headphones are plugged into the jack. This pin can be configured in Register R2 (digital microphone/jack detection control register, Address 0x4008). The JDFUNC[1:0] bits set the functionality of the JACKDET/MICIN pin.

Additional settings for jack detection include debounce time (JDDB[1:0] bits) and detection polarity (JDPOL bit). Because the jack detection and digital microphone share a pin, both functions cannot be used simultaneously.

POP-AND-CLICK SUPPRESSION

Upon power-up, precharge circuitry is enabled to suppress pops and clicks. After power-up, the precharge circuitry can be put into a low power mode using the POPMODE bit in Register R34 (playback pop/click suppression register, Address 0x4028).

The precharge time depends on the capacitor value on the CM pin and the RC time constant of the load. For a typical line output load, the precharge time is between 2 ms and 3 ms. After this precharge time, the POPMODE bit can be set to low power mode.

Changing any register settings that affect the signal path can cause pops and clicks on the analog outputs. To avoid these pops and clicks, mute the appropriate outputs using Register R29 to Register R32 (Address 0x4023 to Address 0x4026). Unmute the analog outputs after the changes are made.

LINE OUTPUTS

The line output pins (LOUTP, LOUTN, ROUTP, and ROUTN) can be used to drive both differential and single-ended loads. In their default settings, these pins can drive typical line loads of 10 k Ω or greater, but they can also be put into headphone mode by setting the LOMODE bit in Register R31 (playback line output left volume control register, Address 0x4025) and the ROMODE bit in Register R32 (playback line output right volume control register, Address 0x4026). In headphone mode, the line output pins are capable of driving headphone and earpiece speakers of 16 Ω or greater. The output impedance of the line outputs is approximately 1 k Ω .

When the line output pins are used in single-ended mode, LOUTP and ROUTP should be used to output the signals, and LOUTN and ROUTN should be left unconnected.

The volume controls for these outputs range from -57 dB to +6 dB. Slew can be applied to all the playback volume controls using the ASLEW[1:0] bits in Register R34 (playback pop/click suppression register, Address 0x4028).

The MX5G4[1:0], MX5G3[1:0], MX6G3[1:0], and MX6G4[1:0] bits can all provide a 6 dB gain boost to the line outputs. This gain boost allows single-ended output signals to achieve 0 dBV (1.0 V rms) and differential output signals to achieve up to 6 dBV (2.0 V rms). For more information, see Register R26 (playback L/R mixer left (Mixer 5) line output control register, Address 0x4020) and Register R27 (playback L/R mixer right (Mixer 6) line output control register, Address 0x4021).

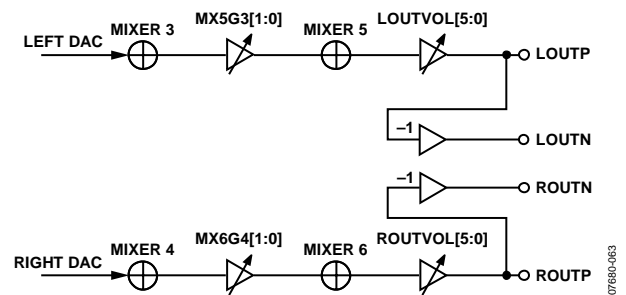

Figure 48. Differential Line Output Configuration

07980-083

CONTROL PORTS

The ADAU1761 can operate in one of two control modes:

- I²C control
- SPI control

The ADAU1761 has both a 4-wire SPI control port and a 2-wire I²C bus control port. Both ports can be used to set the registers. The part defaults to I²C mode, but it can be put into SPI control mode by pulling the CLATCH pin low three times.

The control port is capable of full read/write operation for all addressable registers. The ADAU1761 must have a valid master clock in order to write to all registers except for Register R0 (Address 0x4000) and Register R1 (Address 0x4002).

All addresses can be accessed in both a single-address mode or a burst mode. The first byte (Byte 0) of a control port write contains the 7-bit chip address plus the R/W bit. The next two bytes (Byte 1 and Byte 2) together form the subaddress of the register location within the ADAU1761. This subaddress must be two bytes long because the memory locations within the ADAU1761 are directly addressable and their sizes exceed the range of single-byte addressing. All subsequent bytes (starting with Byte 3) contain the data, such as control port data, program data, or parameter data. The number of bytes per word depends on the type of data that is being written.

The ADAU1761 has several mechanisms for updating signal processing parameters in real time without causing pops or clicks. If large blocks of data need to be downloaded, the output of the DSP core can be halted (using the DSPRUN bit in the DSP run register, Address 0x40F6), new data can be loaded, and the device can be restarted. This is typically done during the booting sequence at start-up or when loading a new program into RAM.

The control port pins are multifunctional, depending on the mode in which the part is operating. Table 20 describes these multiple functions.

Table 20. Control Port Pin Functions

| Pin Name | I ² C Mode | SPI Mode |
|--------------|---------------------------------------|-------------------|
| SCL/CCLK | SCL: input clock | CCLK: input clock |
| SDA/COUT | SDA: open-collector input/output | COUT: output |
| ADDR1/CDATA | I ² C Address Bit 1: input | CDATA: input |
| ADDR0/CLATCH | I ² C Address Bit 0: input | CLATCH: input |

BURST MODE WRITING AND READING

Burst mode addressing, where the subaddresses are automatically incremented at word boundaries, can be used for writing large amounts of data to contiguous registers. This increment happens automatically after a single-word write or read unless a stop condition is encountered (I²C) or CLATCH is brought high (SPI). A burst write starts like a single-word write, but following the first data-word, the data-word for the next immediate address can be written immediately without sending its two-byte address.

The registers in the ADAU1761 are one byte wide with the exception of the PLL control register, which is six bytes wide. The autoincrement feature knows the word length at each subaddress, so the subaddress does not need to be specified manually for each address in a burst write.

The subaddresses are autoincremented by 1 following each read or write of a data-word, regardless of whether there is a valid register or RAM word at that address. Address holes in the register map can be written to or read from without consequence. In the ADAU1761, these address holes exist at Address 0x4001, Address 0x4003 to Address 0x4007, Address 0x402E, Address 0x4032 to Address 0x4035, Address 0x4037 to Address 0x40BF, Address 0x40C5, Address 0x40CA to Address 0x40CF, Address 0x40D5 to Address 0x40EA, and Address 0x40EC to Address 0x40F1. A single-byte write to these registers is ignored by the ADAU1761, and a read returns a single byte 0x00.

I²C PORT

The ADAU1761 supports a 2-wire serial (I²C-compatible) microprocessor bus driving multiple peripherals. Two pins, serial data (SDA) and serial clock (SCL), carry information between the ADAU1761 and the system I²C master controller. In I²C mode, the ADAU1761 is always a slave on the bus, meaning that it cannot initiate a data transfer. Each slave device is recognized by a unique address. The address and R/W byte format is shown in Table 21. The address resides in the first seven bits of the I²C write. Bits[5:6] of the I²C address for the ADAU1761 are set by the levels on the ADDR1 and ADDR0 pins. The LSB of the address—the R/W bit—specifies either a read or write operation. Logic Level 1 corresponds to a read operation, and Logic Level 0 corresponds to a write operation.

Table 21. ADAU1761 I²C Address and Read/Write Byte Format

| Bit 0 | Bit 1 | Bit 2 | Bit 3 | Bit 4 | Bit 5 | Bit 6 | Bit 7 |
|-------|-------|-------|-------|-------|-------|-------|-------|
| 0 | 1 | 1 | 1 | 0 | ADDR1 | ADDR0 | R/W |

The SDA and SCL pins should each have a 2 kΩ pull-up resistor on the line connected to it. The voltage on these signal lines should not be higher than IOVDD (1.8 V to 3.3 V).

Addressing

Initially, each device on the I²C bus is in an idle state and monitors the SDA and SCL lines for a start condition and the proper address. The I²C master initiates a data transfer by establishing a start condition, defined by a high-to-low transition on SDA while SCL remains high. This indicates that an address/data stream follows. All devices on the bus respond to the start condition and shift the next eight bits (the 7-bit address plus the R/W bit) MSB first. The device that recognizes the transmitted address responds by pulling the data line low during the ninth clock pulse. This ninth bit is known as an acknowledge bit. All other devices withdraw from the bus at this point and return to the idle condition.

The R/W bit determines the direction of the data. A Logic 0 on the LSB of the first byte means that the master will write information to the peripheral, whereas a Logic 1 means that the master will read information from the peripheral after writing the subaddress and repeating the start address. A data transfer takes place until a stop condition is encountered. A stop condition occurs when SDA transitions from low to high while SCL is held high. Figure 49 shows the timing of an I²C write, and Figure 50 shows an I²C read.

Stop and start conditions can be detected at any stage during the data transfer. If these conditions are asserted out of sequence with normal read and write operations, the ADAU1761 immediately jumps to the idle condition. During a given SCL high period,

the user should only issue one start condition, one stop condition, or a single stop condition followed by a single start condition. If an invalid subaddress is issued by the user, the ADAU1761 does not issue an acknowledge and returns to the idle condition.

If the user exceeds the highest subaddress while in autoincrement mode, one of two actions is taken. In read mode, the ADAU1761 outputs the highest subaddress register contents until the master device issues a no acknowledge, indicating the end of a read. A no acknowledge condition is where the SDA line is not pulled low on the ninth clock pulse on SCL. If the highest subaddress location is reached while in write mode, the data for the invalid byte is not loaded into any subaddress register, a no acknowledge is issued by the ADAU1761, and the part returns to the idle condition.

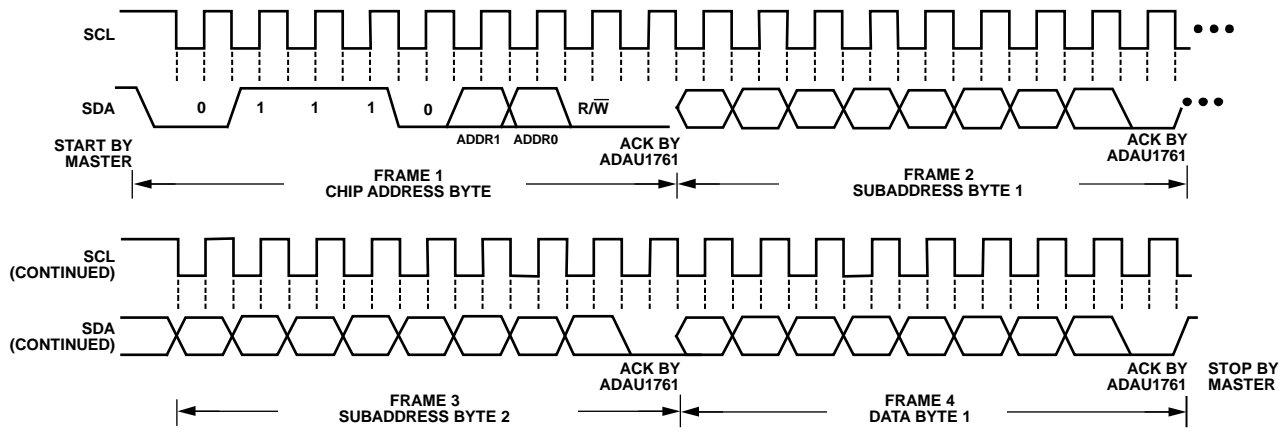

Figure 49. I²C Write to ADAU1761 Clocking

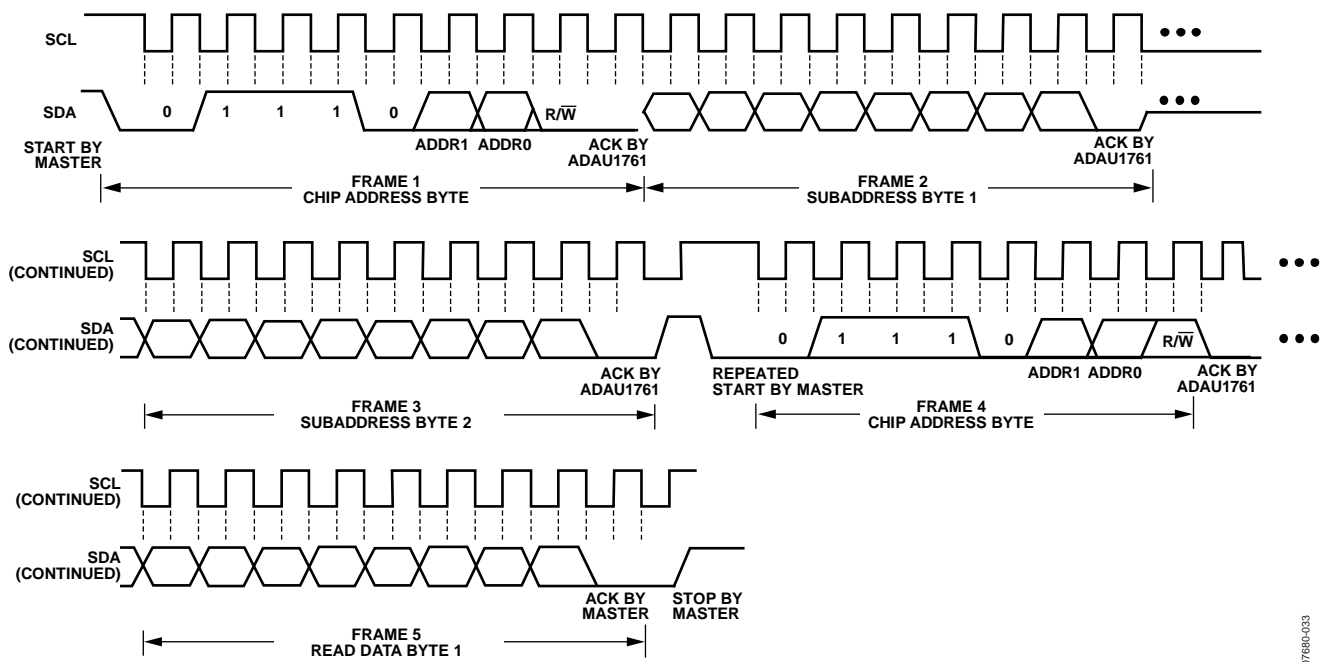

Figure 50. I²C Read from ADAU1761 Clocking

I²C Read and Write Operations

Figure 51 shows the format of a single-word write operation. Every ninth clock pulse, the ADAU1761 issues an acknowledge by pulling SDA low.

Figure 52 shows the format of a burst mode write sequence. This figure shows an example of a write to sequential single-byte registers. The ADAU1761 increments its subaddress register after every byte because the requested subaddress corresponds to a register or memory area with a 1-byte word length.

Figure 53 shows the format of a single-word read operation. Note that the first R/W bit is 0, indicating a write operation. This is because the subaddress still needs to be written to set up the internal address. After the ADAU1761 acknowledges the receipt of the subaddress, the master must issue a repeated start command followed by the chip address byte with the R/W bit set to 1 (read).

This causes the ADAU1761 SDA to reverse and begin driving data back to the master. The master then responds every ninth pulse with an acknowledge pulse to the ADAU1761.

Figure 54 shows the format of a burst mode read sequence. This figure shows an example of a read from sequential single-byte registers. The ADAU1761 increments its subaddress register after every byte because the requested subaddress corresponds to a register or memory area with a 1-byte word length. The ADAU1761 always decodes the subaddress and sets the auto-increment circuit so that the address increments after the appropriate number of bytes.

Figure 51 to Figure 54 use the following abbreviations:

- S = start bit
- P = stop bit
- AM = acknowledge by master
- AS = acknowledge by slave

| | | | | | | | | |
|---|-----------------------|----|----------------------|----|---------------------|----|-------------|---|
| S | Chip address, R/W = 0 | AS | Subaddress high byte | AS | Subaddress low byte | AS | Data Byte 1 | P |
|---|-----------------------|----|----------------------|----|---------------------|----|-------------|---|

Figure 51. Single-Word I²C Write Format

| | | | | | | | | | | | | | | | | |
|---|-----------------------|----|----------------------|----|---------------------|----|-------------|----|-------------|----|-------------|----|-------------|----|-----|---|
| S | Chip address, R/W = 0 | AS | Subaddress high byte | AS | Subaddress low byte | AS | Data Byte 1 | AS | Data Byte 2 | AS | Data Byte 3 | AS | Data Byte 4 | AS | ... | P |
|---|-----------------------|----|----------------------|----|---------------------|----|-------------|----|-------------|----|-------------|----|-------------|----|-----|---|

Figure 52. Burst Mode I²C Write Format

| | | | | | | | | | | | |
|---|-----------------------|----|----------------------|----|---------------------|----|---|-----------------------|----|-------------|---|
| S | Chip address, R/W = 0 | AS | Subaddress high byte | AS | Subaddress low byte | AS | S | Chip address, R/W = 1 | AS | Data Byte 1 | P |
|---|-----------------------|----|----------------------|----|---------------------|----|---|-----------------------|----|-------------|---|

Figure 53. Single-Word I²C Read Format

| | | | | | | | | | | | | | | | |
|---|-----------------------|----|----------------------|----|---------------------|----|---|-----------------------|----|-------------|----|-------------|----|-----|---|
| S | Chip address, R/W = 0 | AS | Subaddress high byte | AS | Subaddress low byte | AS | S | Chip address, R/W = 1 | AS | Data Byte 1 | AM | Data Byte 2 | AM | ... | P |
|---|-----------------------|----|----------------------|----|---------------------|----|---|-----------------------|----|-------------|----|-------------|----|-----|---|

Figure 54. Burst Mode I²C Read Format

SPI PORT

By default, the ADAU1761 is in I²C mode, but it can be put into SPI control mode by pulling $\overline{\text{CLATCH}}$ low three times. This is done by performing three dummy writes to the SPI port (the ADAU1761 does not acknowledge these three writes). Beginning with the fourth SPI write, data can be written to or read from the IC. The ADAU1761 can be taken out of SPI mode only by a full reset initiated by power cycling the IC.

The SPI port uses a 4-wire interface, consisting of the $\overline{\text{CLATCH}}$, CCLK, CDATA, and COUT signals, and it is always a slave port. The $\overline{\text{CLATCH}}$ signal should go low at the beginning of a transaction and high at the end of a transaction. The CCLK signal latches CDATA on a low-to-high transition. COUT data is shifted out of the ADAU1761 on the falling edge of CCLK and should be clocked into a receiving device, such as a microcontroller, on the CCLK rising edge. The CDATA signal carries the serial input data, and the COUT signal carries the serial output data. The COUT signal remains three-state until a read operation is requested. This allows other SPI-compatible peripherals to share the same readback line. All SPI transactions have the same basic format shown in Table 23. A timing diagram is shown in Figure 4. All data should be written MSB first.

Chip Address $\overline{\text{R/W}}$

The LSB of the first byte of an SPI transaction is an $\overline{\text{R/W}}$ bit. This bit determines whether the communication is a read (Logic Level 1) or a write (Logic Level 0). This format is shown in Table 22.

Table 22. ADAU1761 SPI Address and Read/Write Byte Format

| Bit 0 | Bit 1 | Bit 2 | Bit 3 | Bit 4 | Bit 5 | Bit 6 | Bit 7 |
|-------|-------|-------|-------|-------|-------|-------|-------|
| 0 | 0 | 0 | 0 | 0 | 0 | 0 | R/W |

Subaddress

The 16-bit subaddress word is decoded into a location in one of the registers. This subaddress is the location of the appropriate register. The MSBs of the subaddress are zero-padded to bring the word to a full 2-byte length.

Data Bytes

The number of data bytes varies according to the register being accessed. During a burst mode write, an initial subaddress is written followed by a continuous sequence of data for consecutive register locations.

A sample timing diagram for a single-word SPI write operation to a register is shown in Figure 55. A sample timing diagram of a single-word SPI read operation is shown in Figure 56. The COUT pin goes from being three-state to being driven at the beginning of Byte 3. In this example, Byte 0 to Byte 2 contain the addresses and $\overline{\text{R/W}}$ bit, and subsequent bytes carry the data.

Table 23. Generic Control Word Format

| Byte 0 | Byte 1 | Byte 2 | Byte 3 | Byte 4 ¹ |
|--|---------------|--------------|--------|---------------------|
| chip_adr[6:0], $\overline{\text{R/W}}$ | subaddr[15:8] | subaddr[7:0] | data | data |

¹ Continues to end of data.

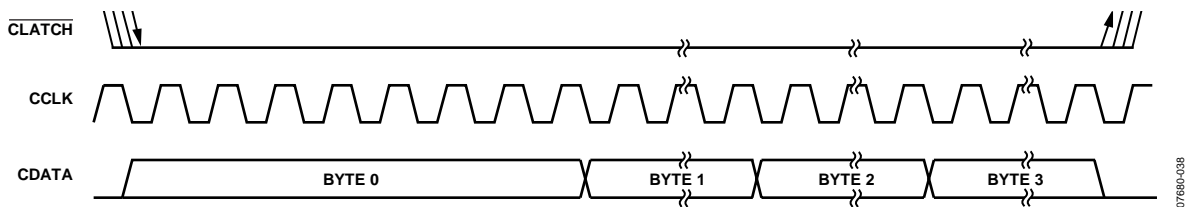

Figure 55. SPI Write to ADAU1761 Clocking (Single-Word Write Mode)

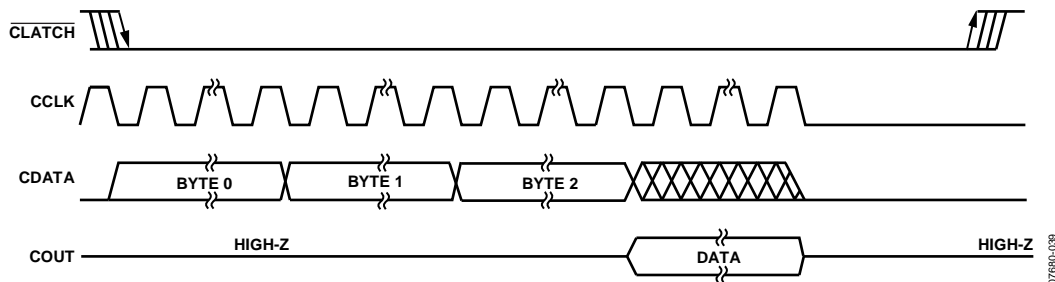

Figure 56. SPI Read from ADAU1761 Clocking (Single-Word Read Mode)

SERIAL DATA INPUT/OUTPUT PORTS

The flexible serial data input and output ports of the ADAU1761 can be set to accept or transmit data in 2-channel format or in a 4-channel or 8-channel TDM stream to interface to external ADCs or DACs. Data is processed in twos complement, MSB first format. The left channel data field always precedes the right channel data field in 2-channel streams. In TDM mode, Slot 0 to Slot 3 are in the first half of the audio frame, and Slot 4 to Slot 7 are in the second half of the frame. The serial modes and the position of the data in the frame are set in Register R15 to Register R18 (serial port and converter control registers, Address 0x4015 to Address 0x4018).

If the PLL of the ADAU1761 is not used, the serial data clocks must be synchronous with the ADAU1761 master clock input. The LRCLK and BCLK pins are used to clock both the serial input and output ports. The ADAU1761 can be set as the master or the slave in a system. Because there is only one set of serial data clocks, the input and output ports must always be both master or both slave.

Register R15 and Register R16 (serial port control registers, Address 0x4015 and Address 0x4016) allow control of clock polarity and data input modes. The valid data formats are I²S, left-justified, right-justified (24-/20-/18-/16-bit), and TDM. In all modes except for the right-justified modes, the serial port inputs an arbitrary number of bits up to a limit of 24. Extra bits do not cause an error, but they are truncated internally.

Table 25. Data Format Configurations

| Format | LRCLK Polarity (LRPOL) | LRCLK Mode (LRMOD) | BCLK Polarity (BPOL) | BCLK Cycles/Audio Frame (BPF[2:0]) | Data Delay from LRCLK Edge (LRDEL[1:0]) |
|-------------------------------------|------------------------------|--------------------|------------------------------|------------------------------------|--|
| I ² S (see Figure 58) | Frame begins on falling edge | 50% duty cycle | Data changes on falling edge | 32 to 64 | Delayed from LRCLK edge by 1 BCLK |
| Left-Justified (see Figure 59) | Frame begins on rising edge | 50% duty cycle | Data changes on falling edge | 32 to 64 | Aligned with LRCLK edge |
| Right-Justified (see Figure 60) | Frame begins on rising edge | 50% duty cycle | Data changes on falling edge | 32 to 64 | Delayed from LRCLK edge by 8 or 16 BCLKs |
| TDM with Clock (see Figure 61) | Frame begins on falling edge | 50% duty cycle | Data changes on falling edge | 64 to 256 | Delayed from start of word clock by 1 BCLK |
| TDM with Pulse (see Figure 62) | Frame begins on rising edge | Pulse | Data changes on falling edge | 64 to 256 | Delayed from start of word clock by 1 BCLK |

The serial port can operate with an arbitrary number of BCLK transitions in each LRCLK frame. The LRCLK in TDM mode can be input to the ADAU1761 either as a 50% duty cycle clock or as a bit-wide pulse.

When the LRCLK is set as a pulse, a 47 pF capacitor should be connected between the LRCLK pin and ground (see Figure 57). This capacitor is necessary in both master and slave modes to properly align the LRCLK signal to the serial data stream.

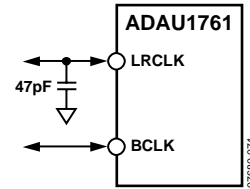

Figure 57. LRCLK Capacitor Alignment, TDM Pulse Mode

In TDM 8 mode, the ADAU1761 can be a master for f_s up to 48 kHz. Table 24 lists the modes in which the serial output port can function.

Table 24. Serial Output Port Master/Slave Mode Capabilities

| f_s | 2-Channel Modes (I ² S, Left-Justified, Right-Justified) | 8-Channel TDM |
|--------|---|------------------|
| 48 kHz | Master and slave | Master and slave |
| 96 kHz | Master and slave | Slave |

Table 25 describes the proper configurations for standard audio data formats.

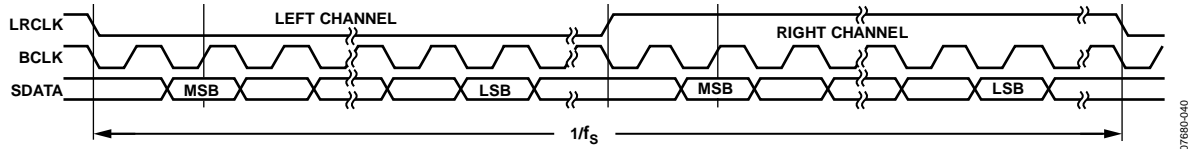

Figure 58. PS Mode—16 Bits to 24 Bits per Channel

07680-040

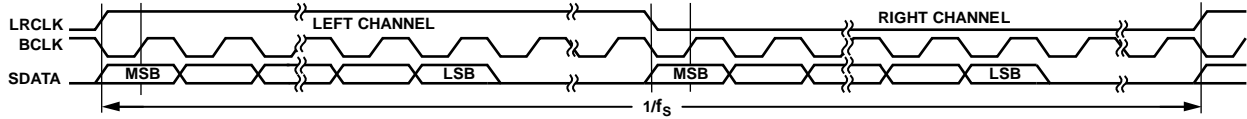

Figure 59. Left-Justified Mode—16 Bits to 24 Bits per Channel

07680-041

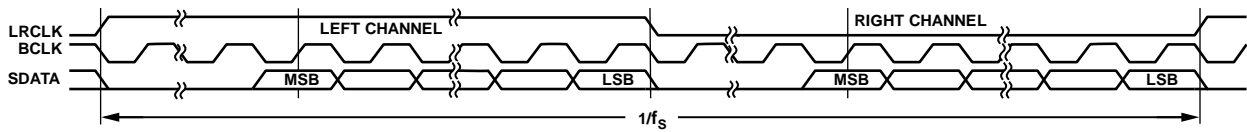

Figure 60. Right-Justified Mode—16 Bits to 24 Bits per Channel

07680-042

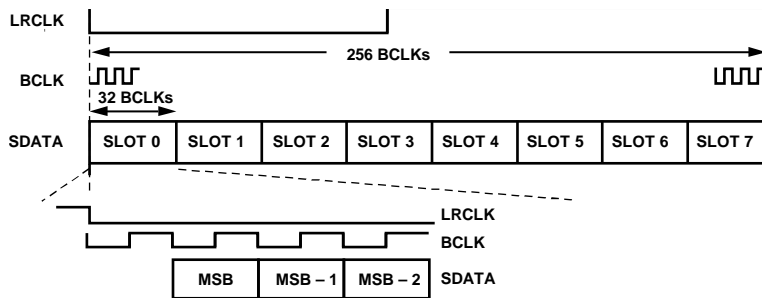

Figure 61. TDM 8 Mode

07680-043

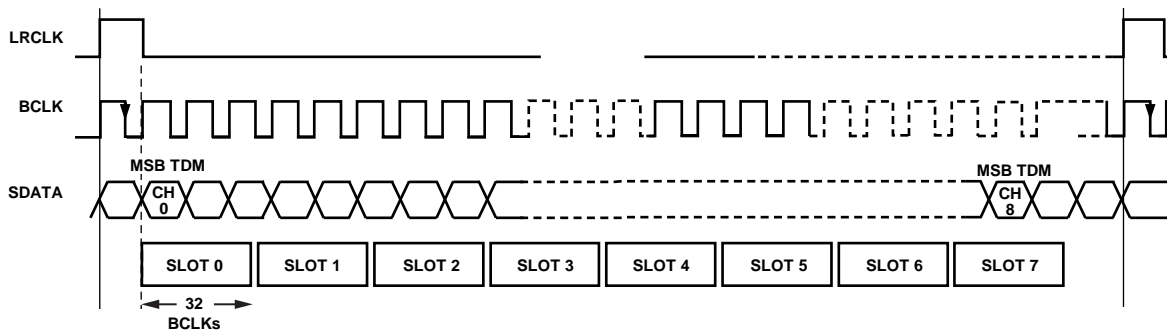

Figure 62. TDM 8 Mode with Pulse Word Clock

07680-044

APPLICATIONS INFORMATION

POWER SUPPLY BYPASS CAPACITORS

Each analog and digital power supply pin should be bypassed to its nearest appropriate ground pin with a single 100 nF capacitor. The connections to each side of the capacitor should be as short as possible, and the trace should stay on a single layer with no vias. For maximum effectiveness, locate the capacitor equidistant from the power and ground pins or, when equidistant placement is not possible, slightly closer to the power pin. Thermal connections to the ground planes should be made on the far side of the capacitor.

Each supply signal on the board should also be bypassed with a single bulk capacitor (10 μ F to 47 μ F).

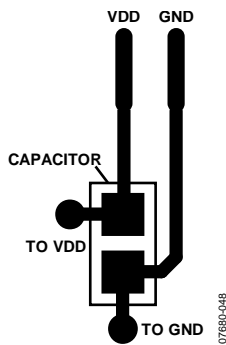

Figure 63. Recommended Power Supply Bypass Capacitor Layout

GSM NOISE FILTER

In mobile phone applications, excessive 217 Hz GSM noise on the analog supply pins can degrade the audio quality. To avoid this problem, it is recommended that an L-C filter be used in series with the bypass capacitors for the AVDD pins. This filter should consist of a 1.2 nH inductor and a 9.1 pF capacitor in series between AVDD and ground, as shown in Figure 64.

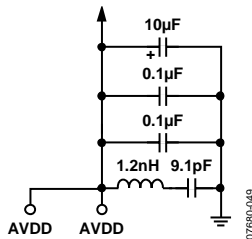

Figure 64. GSM Filter on the Analog Supply Pins

GROUNDING

A single ground plane should be used in the application layout. Components in an analog signal path should be placed away from digital signals.

EXPOSED PAD PCB DESIGN

The ADAU1761 has an exposed pad on the underside of the LFCSP. This pad is used to couple the package to the PCB for heat dissipation when using the outputs to drive earpiece or headphone loads. When designing a board for the ADAU1761, special consideration should be given to the following:

- A copper layer equal in size to the exposed pad should be on all layers of the board, from top to bottom, and should connect somewhere to a dedicated copper board layer (see Figure 65).
- Vias should be placed to connect all layers of copper, allowing for efficient heat and energy conductivity. For an example, see Figure 66, which has nine vias arranged in a 3 inch \times 3 inch grid in the pad area.

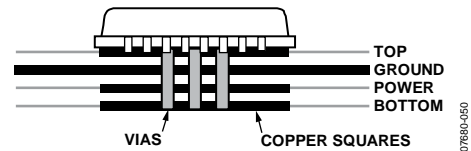

Figure 65. Exposed Pad Layout Example, Side View

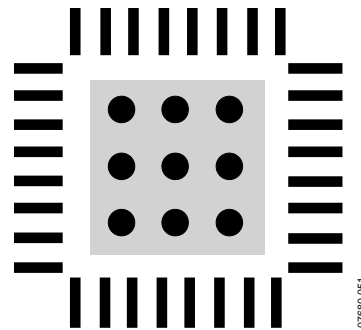

Figure 66. Exposed Pad Layout Example, Top View

DSP CORE

SIGNAL PROCESSING

The ADAU1761 is designed to provide all audio signal processing functions commonly used in stereo or mono low power record and playback systems. The signal processing flow is designed using the SigmaStudio software, which allows graphical entry and real-time control of all signal processing functions.

Many of the signal processing functions are coded using full, 56-bit, double-precision arithmetic data. The input and output word lengths of the DSP core are 24 bits. Four extra headroom bits are used in the processor to allow internal gains of up to 24 dB without clipping. Additional gains can be achieved by initially scaling down the input signal in the DSP signal flow.

ARCHITECTURE

The DSP core consists of a simple 28-/56-bit multiply-accumulate (MAC) unit with two sources: a data source and a coefficient source. The data source can come from the data RAM, a ROM table of commonly used constant values, or the audio inputs to the core. The coefficient source can come from the parameter RAM or from a ROM table of commonly used constant values.

The two sources are multiplied in a 28-bit fixed-point multiplier and then the signal is input to the 56-bit adder; the result is usually stored in one of three 56-bit accumulator registers. The accumulators can be output from the core (in 28-bit format) or can optionally be written back into the data or parameter RAMs.

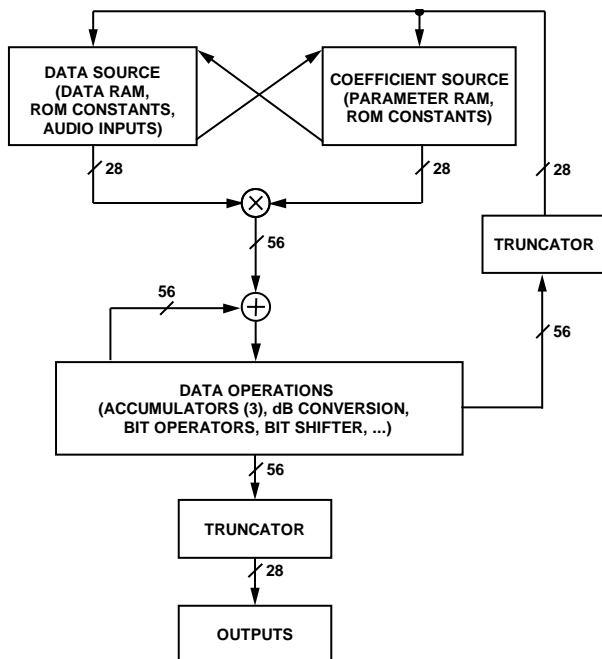

Figure 67. Simplified DSP Core Architecture

PROGRAM COUNTER

The execution of instructions in the core is governed by a program counter, which sequentially steps through the addresses of the program RAM. The program counter starts every time that a new audio frame is clocked into the core. SigmaStudio inserts a jump-to-start command at the end of every program. The program counter increments sequentially until it reaches this command and then jumps to the program start address and waits for the next audio frame to clock into the core.

FEATURES

The SigmaDSP core was designed specifically for audio processing and therefore includes several features intended for maximizing efficiency. These include hardware decibel conversion and audio-specific ROM constants.

STARTUP

Before the DSPRUN bit is set or any settings are written to the parameter RAM, the DSP core must be enabled by setting the DSPEN bit in Register R61 (Address 0x40F5).

The following steps should be performed every time that a new program is loaded to the SigmaDSP core, or any time that the DSPRUN bit is disabled and reenabled.

1. Set the DSPSR[3:0] bits in Register R57 (Address 0x40EB) to 1111 (none).
2. Set the DSPRUN bit in Register R62 (Address 0x40F6) to 0.
3. Download the rest of the registers, the program RAM, and the parameter RAM.
4. Set the DSPRUN bit in Register R62 to 1.
5. Set the DSPSR[3:0] bits in Register R57 to the operational setting (default value is 0001).

Changing any register setting or RAM can cause pops and clicks on the analog outputs. To avoid these pops and clicks, mute the appropriate outputs using Register R29 to Register R32 (Address 0x4023 to Address 0x4026). Unmute the analog outputs after the startup procedure is completed.

勝特力材料 886-3-5753170
 勝特力电子(上海) 86-21-34970699
 勝特力电子(深圳) 86-755-83298787
[Http://www.100y.com.tw](http://www.100y.com.tw)

NUMERIC FORMATS

DSP systems commonly use a standard numeric format. Fractional numeric systems are specified by an A.B format, where A is the number of bits to the left of the decimal point and B is the number of bits to the right of the decimal point.

The ADAU1761 uses numeric format 5.23 for both the parameter and data values.

Numeric Format 5.23

Linear range: -16.0 to $(+16.0 - 1 \text{ LSB})$

Examples:

- 1000 0000 0000 0000 0000 0000 = -16.0
- 1110 0000 0000 0000 0000 0000 = -4.0
- 1111 1000 0000 0000 0000 0000 = -1.0
- 1111 1110 0000 0000 0000 0000 = -0.25
- 1111 1111 0011 0011 0011 0011 = -0.1
- 1111 1111 1111 1111 1111 1111 = (1 LSB below 0)
- 0000 0000 0000 0000 0000 0000 = 0
- 0000 0000 1100 1100 1100 1101 = 0.1
- 0000 0010 0000 0000 0000 0000 = 0.25
- 0000 1000 0000 0000 0000 0000 = 1.0
- 0010 0000 0000 0000 0000 0000 = 4.0
- 0111 1111 1111 1111 1111 1111 = $(16.0 - 1 \text{ LSB})$

The serial port accepts up to 24 bits on the input and is sign-extended to the full 28 bits of the DSP core. This allows internal gains of up to 24 dB without internal clipping.

A digital clipper circuit is used between the output of the DSP core and the DACs or serial port outputs (see Figure 68). This circuit clips the top four bits of the signal to produce a 24-bit output with a range of 1.0 (minus 1 LSB) to -1.0 . Figure 68 shows the maximum signal levels at each point in the data flow in both binary and decibel levels.

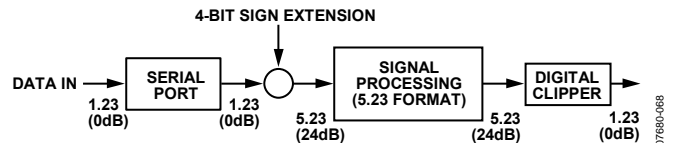

Figure 68. Numeric Precision and Clipping Structure

PROGRAMMING

On power-up, the ADAU1761 must be configured with a clocking scheme and then loaded with register settings. After the codec signal path is set up, the DSP core can be programmed. There are 1024 instruction cycles per audio sample, resulting in an internal clock rate of 49.152 MHz when $f_s = 48 \text{ kHz}$.

The part can be programmed easily using SigmaStudio, a graphical tool provided by Analog Devices (see Figure 69). No knowledge of writing line-level DSP code is required. More information about SigmaStudio can be found at www.analog.com.

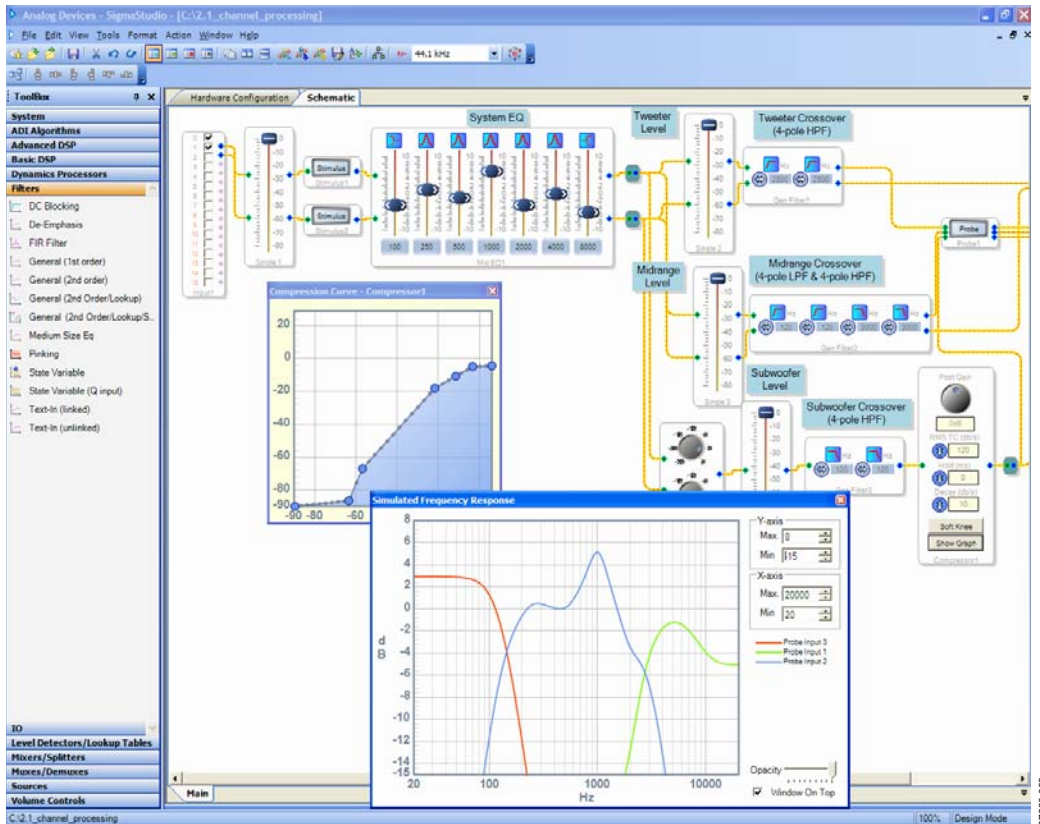

Figure 69. SigmaStudio Screen Shot

PROGRAM RAM, PARAMETER RAM, AND DATA RAM

Table 26. RAM Map and Read/Write Modes

| Memory | Size | Address Range | Read | Write | Write Modes |
|---------------|-----------|---------------------------------|------|-------|------------------|
| Parameter RAM | 1024 × 32 | 0 to 1023 (0x0000 to 0x03FF) | Yes | Yes | Direct, safeload |
| Program RAM | 1024 × 40 | 2048 to 3071 (0x0800 to 0x0BFF) | Yes | Yes | Direct |

Table 26 shows the RAM map (the ADAU1761 register map is provided in the Control Registers section). The address space encompasses a set of registers and three RAMs: program, parameter, and data. The program RAM and parameter RAM are not initialized on power-up and are in an unknown state until written to.

PROGRAM RAM

The program RAM contains the 40-bit operation codes that are executed by the core. The SigmaStudio compiler calculates maximum instructions per frame for a project and generates an error when the value exceeds the maximum allowable instructions per frame based on the sample rate of the signals in the core.

Because the end of a program contains a jump-to-start command, the unused program RAM space does not need to be filled with no-operation (NOP) commands.

PARAMETER RAM

The parameter RAM is 32 bits wide and occupies Address 0 to Address 1023. Each parameter is padded with four 0s before the MSB to extend the 28-bit word to a full 4-byte width. The data format of the parameter RAM is twos complement, 5.23. This means that the coefficients can range from +16.0 (minus 1 LSB) to -16.0, with 1.0 represented by the binary word 0000 1000 0000 0000 0000 0000 or by the hexadecimal word 0x00 0x80 0x00 0x00.

The parameter RAM can be written to directly or with a safe-load write. The direct write mode of operation is typically used during a complete new loading of the RAM using burst mode addressing to avoid any clicks or pops in the outputs. Note that this mode can be used during live program execution, but because there is no handshaking between the core and the control port, the parameter RAM is unavailable to the DSP core during control writes, resulting in pops and clicks in the audio stream.

SigmaStudio automatically assigns the first eight positions to safeload parameters; therefore, project-specific parameters start at Address 0x0008.

The parameter RAM should not be written to until the DSPEN bit has been set in Register R61 (Address 0x40F5).

DATA RAM

The ADAU1761 data RAM is used to store audio data-words for processing, as well as certain run-time parameters. SigmaStudio provides the data and address information for writing to and reading from the data RAM.

When implementing blocks, such as delays, that require large amounts of data RAM space, data RAM utilization should be taken into account. The SigmaDSP core processes delay times in one-sample increments; therefore, the total pool of delay available to the user equals 4096 multiplied by the sample period. For a $f_{s,DSP}$ of 48 kHz, the pool of available delay is a maximum of about 86 ms, where $f_{s,DSP}$ is the DSP core sampling rate. In practice, this much data memory is not available to the user because every block in a design uses a few data memory locations for its processing. In most DSP programs, this does not significantly affect the total delay time. The SigmaStudio compiler manages the data RAM and indicates whether the number of addresses needed in the design exceeds the maximum number available.

READ/WRITE DATA FORMATS

The read/write formats of the control port are designed to be byte oriented to allow for easy programming of common micro-controller chips. To fit into a byte-oriented format, 0s are added to the data fields before the MSB to extend the data-word to eight bits. For example, 28-bit words written to the parameter RAM are preceded by four leading 0s to equal 32 bits (four bytes); 40-bit words written to the program RAM are not preceded by 0s because they are already a full five bytes. These zero-padded data fields are appended to a 3-byte field consisting of a 7-bit chip address, a read/write bit, and a 16-bit RAM/register address. The control port knows how many data bytes to expect based on the address given in the first three bytes.

The total number of bytes for a single-location write command can vary from one byte (for a control register write) to five bytes (for a program RAM write). Burst mode can be used to fill contiguous register or RAM locations. A burst mode write begins by writing the address and data of the first RAM or register location to be written. Rather than ending the control port transaction (by issuing a stop command in I²C mode or by bringing the CLATCH signal high in SPI mode after the data-word), as would be done in a single-address write, the next data-word can be written immediately without specifying its address. The ADAU1761 control port autoincrements the address of each write even across the boundaries of the different RAMs and registers. Table 28 and Table 30 show examples of burst mode writes.

Table 27. Parameter RAM Read/Write Format (Single Address)

| Byte 0 | Byte 1 | Byte 2 | Byte 3 | Bytes[4:6] |
|--------------------|-----------------|----------------|--------------------|-------------|
| chip_adr[6:0], R/W | param_adr[15:8] | param_adr[7:0] | 0000, param[27:24] | param[23:0] |

Table 28. Parameter RAM Block Read/Write Format (Burst Mode)

| Byte 0 | Byte 1 | Byte 2 | Byte 3 | Bytes[4:6] | Bytes[7:10] | Bytes[11:14] |
|--------------------|-----------------|----------------|--------------------|---------------|-------------|---------------|
| chip_adr[6:0], R/W | param_adr[15:8] | param_adr[7:0] | 0000, param[27:24] | param[23:0] | | |
| <—param_adr—> | | | | param_adr + 1 | | param_adr + 2 |

Table 29. Program RAM Read/Write Format (Single Address)

| Byte 0 | Byte 1 | Byte 2 | Bytes[3:7] |
|--------------------|----------------|---------------|------------|
| chip_adr[6:0], R/W | prog_adr[15:8] | prog_adr[7:0] | prog[39:0] |

Table 30. Program RAM Block Read/Write Format (Burst Mode)

| Byte 0 | Byte 1 | Byte 2 | Bytes[3:7] | Bytes[8:12] | Bytes[13:17] |
|--------------------|----------------|---------------|------------|--------------|--------------|
| chip_adr[6:0], R/W | prog_adr[15:8] | prog_adr[7:0] | prog[39:0] | | |
| <—prog_adr—> | | | | prog_adr + 1 | prog_adr + 2 |

SOFTWARE SAFELOAD

To update parameters in real time while avoiding pop and click noises on the output, the ADAU1761 uses a software safeload mechanism. The software safeload mechanism enables the SigmaDSP core to load new parameters into RAM while guaranteeing that the parameters are not in use. This prevents an undesirable condition where an instruction could execute with a mix of old and new parameters.

SigmaStudio sets up the necessary code and parameters automatically for new projects. The safeload code, along with other initialization code, fills the first 39 locations in program RAM. The first eight parameter RAM locations (Address 0x0000 to Address 0x0007) are configured by default in SigmaStudio as described in Table 31.

Table 31. Software Safeload Parameter RAM Defaults

| Address (Hex) | Function |
|---------------|---|
| 0x0000 | Modulo RAM size |
| 0x0001 | Safeload Data 1 |
| 0x0002 | Safeload Data 2 |
| 0x0003 | Safeload Data 3 |
| 0x0004 | Safeload Data 4 |
| 0x0005 | Safeload Data 5 |
| 0x0006 | Safeload target address (offset of -1) |
| 0x0007 | Number of words to write/safeload trigger |

Address 0x0000, which controls the modulo RAM size, is set by SigmaStudio and is based on the dynamic address generator mode of the project.

Parameter RAM Address 0x0001 to Address 0x0005 are the five data slots for storing the data to be safeloaded. The safeload parameter space contains five data slots by default because most standard signal processing algorithms have five parameters or less.

Address 0x0006 is the target address in parameter RAM (with an offset of -1). This designates the first address to be written. If more than one word is written, the address increments automatically for each data-word. Up to five sequential parameter RAM locations can be updated with safeload during each audio frame. The target address offset of -1 is used because the write address is calculated relative to the address of the data, which starts at Address 0x0001. Therefore, to update a parameter at Address 0x000A, the target address is 0x0009.

Address 0x0007 designates the number of words to be written into the parameter RAM during the safeload. A biquad filter uses all five safeload data addresses. A simple mono gain cell uses only one safeload data address. Writing to Address 0x0007 also triggers the safeload write to occur in the next audio frame.

The safeload mechanism is software based and executes once per audio frame. Therefore, system designers must take care when designing the communication protocol. A delay equal to or greater than the sampling period (the inverse of sampling frequency) is required between each safeload write. A sample rate of 48 kHz equates to a delay of at least 21 μs. If this delay is not observed, the downloaded data is corrupted.

SOFTWARE SLEW

When the values of signal processing parameters are changed abruptly in real time, they sometimes cause pop and click sounds to appear on the audio outputs. To avoid pops and clicks, some algorithms in SigmaStudio implement a software slew functionality. Algorithms using software slew set a target value for a parameter and continuously update the value of that parameter until it reaches the target.

The target value takes an additional space in parameter RAM, and the current value of the parameter is updated in the non-modulo section of data RAM. Assignment of parameters and nonmodulo data RAM is handled by the SigmaStudio compiler and does not need to be programmed manually.

Slew parameters can follow several different curves, including an RC-type curve and a linear curve. These curve types are coded into each algorithm and cannot be modified by the user.

Because algorithms that use software slew generally require more RAM than their nonslew equivalents, they should be used only in situations where a parameter will change during operation of the device.

Figure 70 shows an example of volume slew applied to a sine wave.

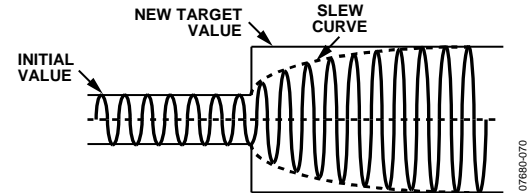

Figure 70. Example of Volume Slew

GENERAL-PURPOSE INPUT/OUTPUT

The serial data input/output pins (Pin 26 to Pin 29) are shared with the general-purpose input/output function. Each of these four pins can be set to only one of these functions. The function of these pins is set in the serial data/GPIO pin configuration register (Register R60, Address 0x40F4).

The GPIOx pins can be used as inputs or outputs. These pins are readable and can be set through the control port or directly by the SigmaDSP core. When configured as inputs, the GPIOx pins can be used with push-button switches or rotary encoders to control DSP program settings. These pins can also be used with digital outputs to drive LEDs or external logic to indicate the status of internal signals and control other devices. Examples of this use include indicating signal overload, signal present, and button press confirmation.

When configured as an output, each GPIO pin can typically drive 2 mA, which is enough current to directly drive some high efficiency LEDs. Standard LEDs require about 20 mA of current and can be driven from a GPIO output with an external transistor or buffer. Because of problems that can arise from simultaneously driving or sinking a large amount of current on many pins, avoid connecting high efficiency LEDs directly to many or all of the GPIO pins when designing the application.

If many LEDs are required, use an external driver. When the GPIO pins are configured as open-collector outputs, they should be pulled up to a maximum voltage equal to the voltage set on IOVDD.

The configuration of the GPIO functions is set up in the GPIO pin control registers (Register R48 to Register R51, Address 0x40C6 to Address 0x40C9).

GPIO PINS SET FROM THE CONTROL PORT

The GPIO pins can also be configured to be directly controlled from the I²C/SPI control port. When the pins are set to this mode, four memory locations are enabled for the GPIO pin settings. The physical settings on the GPIO pins mirror the settings of the LSB of these 4-byte-wide memory locations.

Table 32. GPIOx Pin Memory Settings (Set from Control Port)

| Memory Location | | Bits[31:1] | Bit 0 |
|-----------------|--------|------------|----------|
| Decimal | Hex | | |
| 1568 | 0x0620 | Reserved | GPIO0SET |
| 1569 | 0x0621 | Reserved | GPIO1SET |
| 1570 | 0x0622 | Reserved | GPIO2SET |
| 1571 | 0x0623 | Reserved | GPIO3SET |

CONTROL REGISTERS

Table 33. Register Map

| Reg | Address | Name | Bit 7 | Bit 6 | Bit 5 | Bit 4 | Bit 3 | Bit 2 | Bit 1 | Bit 0 | Default | |
|----------|---------|-------------------------|--------------|-------------|--------------|--------------|--------------|--------------|-------------|----------|----------|----------|
| R0 | 0x4000 | Clock control | Reserved | | | | CLKSRC | INFREQ[1:0] | | COREN | 00000000 | |
| R1 | 0x4002 | PLL control | M[15:8] | | | | | | | | 00000000 | |
| | | | M[7:0] | | | | | | | | 11111101 | |
| | | | N[15:8] | | | | | | | | 00000000 | |
| | | | N[7:0] | | | | | | | | 00001100 | |
| | | | Reserved | R[3:0] | | | | X[1:0] | | Type | 00010000 | |
| Reserved | | | | | | | Lock | PLLEN | 00000000 | | | |
| R2 | 0x4008 | Dig mic/jack detect | JDDDB[1:0] | | JDFUNC[1:0] | | Reserved | | JDPOL | 00000000 | | |
| R3 | 0x4009 | Rec power mgmt | Reserved | MXBIAS[1:0] | | ADCBIAS[1:0] | | RBIAS[1:0] | | Reserved | 00000000 | |
| R4 | 0x400A | Rec Mixer Left 0 | Reserved | LINPG[2:0] | | | LINNG[2:0] | | | MX1EN | 00000000 | |
| R5 | 0x400B | Rec Mixer Left 1 | Reserved | | | LDBOOST[1:0] | | MX1AUXG[2:0] | | | 00000000 | |
| R6 | 0x400C | Rec Mixer Right 0 | Reserved | RINPG[2:0] | | | RINNG[2:0] | | | MX2EN | 00000000 | |
| R7 | 0x400D | Rec Mixer Right 1 | Reserved | | | RDBOOST[1:0] | | MX2AUXG[2:0] | | | 00000000 | |
| R8 | 0x400E | Left diff input vol | LDVOL[5:0] | | | | | | LDMUTE | LDEN | 00000000 | |
| R9 | 0x400F | Right diff input vol | RDVOL[5:0] | | | | | | RDMUTE | RDEN | 00000000 | |
| R10 | 0x4010 | Record mic bias | Reserved | | | | MPERF | MBI | Reserved | MBIEN | 00000000 | |
| R11 | 0x4011 | ALC 0 | PGASLEW[1:0] | | ALCMAX[2:0] | | | ALCSEL[2:0] | | | 00000000 | |
| R12 | 0x4012 | ALC 1 | ALCHOLD[3:0] | | | | ALCTARG[3:0] | | | | 00000000 | |
| R13 | 0x4013 | ALC 2 | ALCATCK[3:0] | | | | ALCDEC[3:0] | | | | 00000000 | |
| R14 | 0x4014 | ALC 3 | NGTYP[1:0] | | NGEN | | NGTHR[4:0] | | | | 00000000 | |
| R15 | 0x4015 | Serial Port 0 | Reserved | SPSRS | LRMOD | BPOL | LRPOL | CHPF[1:0] | | MS | 00000000 | |
| R16 | 0x4016 | Serial Port 1 | BPF[2:0] | | | ADTDM | DATDM | MSBP | LRDEL[1:0] | | 00000000 | |
| R17 | 0x4017 | Converter 0 | Reserved | DAPAIR[1:0] | | DAOSR | ADOSR | CONVSR[2:0] | | | 00000000 | |
| R18 | 0x4018 | Converter 1 | Reserved | | | | | | ADPAIR[1:0] | | 00000000 | |
| R19 | 0x4019 | ADC control | Reserved | ADCPOL | HPF | DMPOL | DMSW | INSEL | ADCEN[1:0] | | 00010000 | |
| R20 | 0x401A | Left digital vol | LADVOL[7:0] | | | | | | | | 00000000 | |
| R21 | 0x401B | Right digital vol | RADVOL[7:0] | | | | | | | | 00000000 | |
| R22 | 0x401C | Play Mixer Left 0 | Reserved | MX3RM | MX3LM | MX3AUXG[3:0] | | | | MX3EN | 00000000 | |
| R23 | 0x401D | Play Mixer Left 1 | MX3G2[3:0] | | | | MX3G1[3:0] | | | | 00000000 | |
| R24 | 0x401E | Play Mixer Right 0 | Reserved | MX4RM | MX4LM | MX4AUXG[3:0] | | | | MX4EN | 00000000 | |
| R25 | 0x401F | Play Mixer Right 1 | MX4G2[3:0] | | | | MX4G1[3:0] | | | | 00000000 | |
| R26 | 0x4020 | Play L/R mixer left | Reserved | | | MX5G4[1:0] | | MX5G3[1:0] | | MX5EN | 00000000 | |
| R27 | 0x4021 | Play L/R mixer right | Reserved | | | MX6G4[1:0] | | MX6G3[1:0] | | MX6EN | 00000000 | |
| R28 | 0x4022 | Play L/R mixer mono | Reserved | | | | | | MX7[1:0] | | MX7EN | 00000000 |
| R29 | 0x4023 | Play HP left vol | LHPVOL[5:0] | | | | | | LHPM | HPEN | 00000010 | |
| R30 | 0x4024 | Play HP right vol | RHPVOL[5:0] | | | | | | RHPM | HPMODE | 00000010 | |
| R31 | 0x4025 | Line output left vol | LOUTVOL[5:0] | | | | | | LOUTM | LOMODE | 00000010 | |
| R32 | 0x4026 | Line output right vol | ROUTVOL[5:0] | | | | | | ROUTM | ROMODE | 00000010 | |
| R33 | 0x4027 | Play mono output | MONOVOL[5:0] | | | | | | MONOM | MOMODE | 00000010 | |
| R34 | 0x4028 | Pop/click suppress | Reserved | | | POPMODE | POPLESS | ASLEW[1:0] | | Reserved | 00000000 | |
| R35 | 0x4029 | Play power mgmt | HPBIAS[1:0] | | DACBIAS[1:0] | | PBIAS[1:0] | | PREN | PLEN | 00000000 | |
| R36 | 0x402A | DAC Control 0 | DACMONO[1:0] | | DACPOL | Reserved | | DEMPH | DACEN[1:0] | | 00000000 | |
| R37 | 0x402B | DAC Control 1 | LDAVOL[7:0] | | | | | | | | 00000000 | |
| R38 | 0x402C | DAC Control 2 | RDAVOL[7:0] | | | | | | | | 00000000 | |
| R39 | 0x402D | Serial port pad | ADCSDP[1:0] | | DACSDP[1:0] | | LRCLKP[1:0] | | BCLKP[1:0] | | 10101010 | |
| R40 | 0x402F | Control Port Pad 0 | CDATP[1:0] | | CLCHP[1:0] | | SCLP[1:0] | | SDAP[1:0] | | 10101010 | |
| R41 | 0x4030 | Control Port Pad 1 | Reserved | | | | | | | | SDASTR | 00000000 |
| R42 | 0x4031 | Jack detect pin | Reserved | | JDSTR | Reserved | JDP[1:0] | | Reserved | | 00001000 | |
| R67 | 0x4036 | Dejitter control | DEJIT[7:0] | | | | | | | | 00000011 | |
| R43 | 0x40C0 | Cyclic redundancy check | CRC[31:24] | | | | | | | | 00000000 | |
| R44 | 0x40C1 | | CRC[23:16] | | | | | | | | 00000000 | |
| R45 | 0x40C2 | | CRC[15:8] | | | | | | | | 00000000 | |

| Reg | Address | Name | Bit 7 | Bit 6 | Bit 5 | Bit 4 | Bit 3 | Bit 2 | Bit 1 | Bit 0 | Default |
|-----|---------|------------------------------------|------------|--------|-------|-------|-------------|-----------|--------|--------|----------|
| R46 | 0x40C3 | | CRC[7:0] | | | | | | | | 00000000 |
| R47 | 0x40C4 | CRC enable | Reserved | | | | | | | CRCEN | 00000000 |
| R48 | 0x40C6 | GPIO0 pin control | Reserved | | | | GPIO0[3:0] | | | | 00000000 |
| R49 | 0x40C7 | GPIO1 pin control | Reserved | | | | GPIO1[3:0] | | | | 00000000 |
| R50 | 0x40C8 | GPIO2 pin control | Reserved | | | | GPIO2[3:0] | | | | 00000000 |
| R51 | 0x40C9 | GPIO3 pin control | Reserved | | | | GPIO3[3:0] | | | | 00000000 |
| R52 | 0x40D0 | Watchdog enable | Reserved | | | | | | | DOGEN | 00000000 |
| R53 | 0x40D1 | Watchdog value | DOG[23:16] | | | | | | | | 00000000 |
| R54 | 0x40D2 | | DOG[15:8] | | | | | | | | 00000000 |
| R55 | 0x40D3 | | DOG[7:0] | | | | | | | | 00000000 |
| R56 | 0x40D4 | Watchdog error | Reserved | | | | | | | DOGER | 00000000 |
| R57 | 0x40EB | DSP sampling rate setting | Reserved | | | | DSPSR[3:0] | | | | 00000001 |
| R58 | 0x40F2 | Serial input route control | Reserved | | | | SINRT[3:0] | | | | 00000000 |
| R59 | 0x40F3 | Serial output route control | Reserved | | | | SOUTRT[3:0] | | | | 00000000 |
| R60 | 0x40F4 | Serial data/GPIO pin configuration | Reserved | | | | LRGP3 | BGP2 | SDOGP1 | SDIGP0 | 00000000 |
| R61 | 0x40F5 | DSP enable | Reserved | | | | | | | DSPEN | 00000000 |
| R62 | 0x40F6 | DSP run | Reserved | | | | | | | DSPRUN | 00000000 |
| R63 | 0x40F7 | DSP slew modes | Reserved | | | MOSLW | ROSLW | LOSLW | RHPSLW | LHPSLW | 00000000 |
| R64 | 0x40F8 | Serial port sampling rate | Reserved | | | | | SPSR[2:0] | | | 00000000 |
| R65 | 0x40F9 | Clock Enable 0 | Reserved | SLEWPD | ALCPD | DECPD | SOUTPD | INTPD | SINPD | SPPD | 00000000 |
| R66 | 0x40FA | Clock Enable 1 | Reserved | | | | | | CLK1 | CLK0 | 00000000 |

CONTROL REGISTER DETAILS

All registers except for the PLL control register are 1-byte write and read registers.

R0: Clock Control, 16,384 (0x4000)

| Bit 7 | Bit 6 | Bit 5 | Bit 4 | Bit 3 | Bit 2 | Bit 1 | Bit 0 |
|----------|-------|-------|-------|--------|-------------|-------|-------|
| Reserved | | | | CLKSRC | INFREQ[1:0] | | COREN |

Table 34. Clock Control Register

| Bits | Bit Name | Description | | | | | | | | | | |
|---------|----------------------------|---|---------|-----------------------|----|----------------------------|----|------------------|----|------------------|----|-------------------|
| 3 | CLKSRC | Clock source select. 0 = direct from MCLK pin (default). 1 = PLL clock. | | | | | | | | | | |
| [2:1] | INFREQ[1:0] | Input clock frequency. Sets the core clock rate that generates the core clock. If the PLL is used, this value is automatically set to $1024 \times f_s$. | | | | | | | | | | |
| | | <table border="1"> <thead> <tr> <th>Setting</th> <th>Input Clock Frequency</th> </tr> </thead> <tbody> <tr> <td>00</td> <td>$256 \times f_s$ (default)</td> </tr> <tr> <td>01</td> <td>$512 \times f_s$</td> </tr> <tr> <td>10</td> <td>$768 \times f_s$</td> </tr> <tr> <td>11</td> <td>$1024 \times f_s$</td> </tr> </tbody> </table> | Setting | Input Clock Frequency | 00 | $256 \times f_s$ (default) | 01 | $512 \times f_s$ | 10 | $768 \times f_s$ | 11 | $1024 \times f_s$ |
| Setting | Input Clock Frequency | | | | | | | | | | | |
| 00 | $256 \times f_s$ (default) | | | | | | | | | | | |
| 01 | $512 \times f_s$ | | | | | | | | | | | |
| 10 | $768 \times f_s$ | | | | | | | | | | | |
| 11 | $1024 \times f_s$ | | | | | | | | | | | |
| 0 | COREN | Core clock enable. Only the R0 and R1 registers can be accessed when this bit is set to 0 (core clock disabled). 0 = core clock disabled (default). 1 = core clock enabled. | | | | | | | | | | |

R1: PLL Control, 16,386 (0x4002)

| Byte | Bit 7 | Bit 6 | Bit 5 | Bit 4 | Bit 3 | Bit 2 | Bit 1 | Bit 0 |
|------|----------|-------|----------|-------|-------|---------|-------|-------|
| 0 | | | | | | M[15:8] | | |
| 1 | | | | | | M[7:0] | | |
| 2 | | | | | | N[15:8] | | |
| 3 | | | | | | N[7:0] | | |
| 4 | Reserved | | R[3:0] | | | X[1:0] | | Type |
| 5 | | | Reserved | | | | Lock | PLLEN |

Table 35. PLL Control Register

| Byte | Bits | Bit Name | Description | | | | | | | | | | | | | | | | | | |
|---------------|--------------|---------------|--|---------------|--------------|------------|-------------|----------|---|------|-----|------|----------|----------|---------------|------|-----|------|----------|----------|--------|
| 0 | [7:0] | M[15:8] | PLL denominator MSB. This value is concatenated with M[7:0] to make up a 16-bit number. | | | | | | | | | | | | | | | | | | |
| 1 | [7:0] | M[7:0] | PLL denominator LSB. This value is concatenated with M[15:8] to make up a 16-bit number. | | | | | | | | | | | | | | | | | | |
| | | | <table border="1"> <thead> <tr> <th>M[15:8] (MSB)</th> <th>M[7:0] (LSB)</th> <th>Value of M</th> </tr> </thead> <tbody> <tr> <td>00000000</td> <td>00000000</td> <td>0</td> </tr> <tr> <td>...</td> <td>...</td> <td>...</td> </tr> <tr> <td>00000000</td> <td>11111101</td> <td>253 (default)</td> </tr> <tr> <td>...</td> <td>...</td> <td>...</td> </tr> <tr> <td>11111111</td> <td>11111111</td> <td>65,535</td> </tr> </tbody> </table> | M[15:8] (MSB) | M[7:0] (LSB) | Value of M | 00000000 | 00000000 | 0 | ... | ... | ... | 00000000 | 11111101 | 253 (default) | ... | ... | ... | 11111111 | 11111111 | 65,535 |
| M[15:8] (MSB) | M[7:0] (LSB) | Value of M | | | | | | | | | | | | | | | | | | | |
| 00000000 | 00000000 | 0 | | | | | | | | | | | | | | | | | | | |
| ... | ... | ... | | | | | | | | | | | | | | | | | | | |
| 00000000 | 11111101 | 253 (default) | | | | | | | | | | | | | | | | | | | |
| ... | ... | ... | | | | | | | | | | | | | | | | | | | |
| 11111111 | 11111111 | 65,535 | | | | | | | | | | | | | | | | | | | |
| 2 | [7:0] | N[15:8] | PLL numerator MSB. This value is concatenated with N[7:0] to make up a 16-bit number. | | | | | | | | | | | | | | | | | | |
| 3 | [7:0] | N[7:0] | PLL numerator LSB. This value is concatenated with N[15:8] to make up a 16-bit number. | | | | | | | | | | | | | | | | | | |
| | | | <table border="1"> <thead> <tr> <th>N[15:8] (MSB)</th> <th>N[7:0] (LSB)</th> <th>Value of N</th> </tr> </thead> <tbody> <tr> <td>00000000</td> <td>00000000</td> <td>0</td> </tr> <tr> <td>...</td> <td>...</td> <td>...</td> </tr> <tr> <td>00000000</td> <td>00001100</td> <td>12 (default)</td> </tr> <tr> <td>...</td> <td>...</td> <td>...</td> </tr> <tr> <td>11111111</td> <td>11111111</td> <td>65,535</td> </tr> </tbody> </table> | N[15:8] (MSB) | N[7:0] (LSB) | Value of N | 00000000 | 00000000 | 0 | ... | ... | ... | 00000000 | 00001100 | 12 (default) | ... | ... | ... | 11111111 | 11111111 | 65,535 |
| N[15:8] (MSB) | N[7:0] (LSB) | Value of N | | | | | | | | | | | | | | | | | | | |
| 00000000 | 00000000 | 0 | | | | | | | | | | | | | | | | | | | |
| ... | ... | ... | | | | | | | | | | | | | | | | | | | |
| 00000000 | 00001100 | 12 (default) | | | | | | | | | | | | | | | | | | | |
| ... | ... | ... | | | | | | | | | | | | | | | | | | | |
| 11111111 | 11111111 | 65,535 | | | | | | | | | | | | | | | | | | | |
| 4 | [6:3] | R[3:0] | PLL integer setting. | | | | | | | | | | | | | | | | | | |
| | | | <table border="1"> <thead> <tr> <th>Setting</th> <th>Value of R</th> </tr> </thead> <tbody> <tr> <td>0010</td> <td>2 (default)</td> </tr> <tr> <td>0011</td> <td>3</td> </tr> <tr> <td>0100</td> <td>4</td> </tr> <tr> <td>0101</td> <td>5</td> </tr> <tr> <td>0110</td> <td>6</td> </tr> <tr> <td>0111</td> <td>7</td> </tr> <tr> <td>1000</td> <td>8</td> </tr> </tbody> </table> | Setting | Value of R | 0010 | 2 (default) | 0011 | 3 | 0100 | 4 | 0101 | 5 | 0110 | 6 | 0111 | 7 | 1000 | 8 | | |
| Setting | Value of R | | | | | | | | | | | | | | | | | | | | |
| 0010 | 2 (default) | | | | | | | | | | | | | | | | | | | | |
| 0011 | 3 | | | | | | | | | | | | | | | | | | | | |
| 0100 | 4 | | | | | | | | | | | | | | | | | | | | |
| 0101 | 5 | | | | | | | | | | | | | | | | | | | | |
| 0110 | 6 | | | | | | | | | | | | | | | | | | | | |
| 0111 | 7 | | | | | | | | | | | | | | | | | | | | |
| 1000 | 8 | | | | | | | | | | | | | | | | | | | | |
| 4 | [2:1] | X[1:0] | PLL input clock divider. | | | | | | | | | | | | | | | | | | |
| | | | <table border="1"> <thead> <tr> <th>Setting</th> <th>Value of X</th> </tr> </thead> <tbody> <tr> <td>00</td> <td>1 (default)</td> </tr> <tr> <td>01</td> <td>2</td> </tr> <tr> <td>10</td> <td>3</td> </tr> <tr> <td>11</td> <td>4</td> </tr> </tbody> </table> | Setting | Value of X | 00 | 1 (default) | 01 | 2 | 10 | 3 | 11 | 4 | | | | | | | | |
| Setting | Value of X | | | | | | | | | | | | | | | | | | | | |
| 00 | 1 (default) | | | | | | | | | | | | | | | | | | | | |
| 01 | 2 | | | | | | | | | | | | | | | | | | | | |
| 10 | 3 | | | | | | | | | | | | | | | | | | | | |
| 11 | 4 | | | | | | | | | | | | | | | | | | | | |
| 4 | 0 | Type | Type of PLL. When set to integer mode, the values of M and N are ignored. 0 = integer (default). 1 = fractional. | | | | | | | | | | | | | | | | | | |
| 5 | 1 | Lock | PLL lock. This read-only bit is flagged when the PLL has finished locking. 0 = PLL unlocked (default). 1 = PLL locked. | | | | | | | | | | | | | | | | | | |
| 5 | 0 | PLLEN | PLL enable. 0 = PLL disabled (default). 1 = PLL enabled. | | | | | | | | | | | | | | | | | | |

R2: Digital Microphone/Jack Detection Control, 16,392 (0x4008)

| | | | | | | | |
|--------------|--------------|--------------|--------------|--------------|--------------|--------------|--------------|
| Bit 7 | Bit 6 | Bit 5 | Bit 4 | Bit 3 | Bit 2 | Bit 1 | Bit 0 |
| JDDDB[1:0] | | JDFUNC[1:0] | | Reserved | | | JDPOL |

Table 36. Digital Microphone/Jack Detection Control Register

| Bits | Bit Name | Description | |
|-------------|-----------------|--|---------------------------|
| [7:6] | JDDDB[1:0] | Jack detect debounce time. | |
| | | Setting | Debounce Time |
| | | 00 | 5 ms (default) |
| | | 01 | 10 ms |
| | | 10 | 20 ms |
| [5:4] | JDFUNC[1:0] | JACKDET/MICIN pin function. Enables or disables the jack detect function or configures the pin for a digital microphone input. | |
| | | Setting | Pin Function |
| | | 00 | Jack detect off (default) |
| | | 01 | Jack detect on |
| | | 10 | Digital microphone input |
| 0 | JDPOL | Jack detect polarity. Detects high or low signal. 0 = detect high signal (default). 1 = detect low signal. | |

R3: Record Power Management, 16,393 (0x4009)

This register manages the power consumption for the record path. In particular, the current distribution for the mixer boosts, ADCs, record path mixers, and PGAs can be set to one of four modes. These settings are normal operation, power saving mode, enhanced performance mode, and extreme power saving mode. Each of these modes draws current from a central bias. Enhanced performance mode offers the highest performance with the trade-off of higher power consumption.

| Bit 7 | Bit 6 | Bit 5 | Bit 4 | Bit 3 | Bit 2 | Bit 1 | Bit 0 |
|----------|-------------|-------|--------------|-------|------------|-------|----------|
| Reserved | MXBIAS[1:0] | | ADCBIAS[1:0] | | RBIAS[1:0] | | Reserved |

Table 37. Record Power Management Register

| Bits | Bit Name | Description | |
|-------|--------------|---|---------------------------------|
| [6:5] | MXBIAS[1:0] | Mixer amplifier bias boost. Sets the boost level for the bias current of the record path mixers. In some cases, the boost level enhances the THD + N performance. | |
| | | Setting | Boost Level |
| | | 00 | Normal operation (default) |
| | | 01 | Boost Level 1 |
| | | 10 | Boost Level 2 |
| [4:3] | ADCBIAS[1:0] | ADC bias control. Sets the bias current for the ADCs based on the mode of operation selected. | |
| | | Setting | ADC Bias Control |
| | | 00 | Normal operation (default) |
| | | 01 | Extreme power saving |
| | | 10 | Enhanced performance |
| [2:1] | RBIAS[1:0] | Record path bias control. Sets the bias current for the PGAs and mixers in the record path. | |
| | | Setting | Record Path Bias Control |
| | | 00 | Normal operation (default) |
| | | 01 | Reserved |
| | | 10 | Enhanced performance |
| | | 11 | Power saving |

R4: Record Mixer Left (Mixer 1) Control 0, 16,394 (0x400A)

This register controls the gain of single-ended inputs for the left channel record path. The left channel record mixer is referred to as Mixer 1.

| Bit 7 | Bit 6 | Bit 5 | Bit 4 | Bit 3 | Bit 2 | Bit 1 | Bit 0 |
|----------|------------|-------|-------|------------|-------|-------|-------|
| Reserved | LINPG[2:0] | | | LINNG[2:0] | | | MX1EN |

Table 38. Record Mixer Left (Mixer 1) Control 0 Register

| Bits | Bit Name | Description | |
|-------|------------|--|----------------|
| [6:4] | LINPG[2:0] | Gain for a left channel single-ended input from the LINP pin, input to Mixer 1. | |
| | | Setting | Gain |
| | | 000 | Mute (default) |
| | | 001 | -12 dB |
| | | 010 | -9 dB |
| | | 011 | -6 dB |
| | | 100 | -3 dB |
| | | 101 | 0 dB |
| | | 110 | 3 dB |
| | | 111 | 6 dB |
| [3:1] | LINNG[2:0] | Gain for a left channel single-ended input from the LINN pin, input to Mixer 1. | |
| | | Setting | Gain |
| | | 000 | Mute (default) |
| | | 001 | -12 dB |
| | | 010 | -9 dB |
| | | 011 | -6 dB |
| | | 100 | -3 dB |
| | | 101 | 0 dB |
| | | 110 | 3 dB |
| | | 111 | 6 dB |
| 0 | MX1EN | Left channel mixer enable in the record path. Referred to as Mixer 1. 0 = mixer disabled (default). 1 = mixer enabled. | |

R5: Record Mixer Left (Mixer 1) Control 1, 16,395 (0x400B)

This register controls the gain boost of the left channel differential PGA input and the gain for the left channel auxiliary input in the record path. The left channel record mixer is referred to as Mixer 1.

| Bit 7 | Bit 6 | Bit 5 | Bit 4 | Bit 3 | Bit 2 | Bit 1 | Bit 0 |
|----------|-------|-------|--------------|-------|--------------|-------|-------|
| Reserved | | | LDBOOST[1:0] | | MX1AUXG[2:0] | | |

Table 39. Record Mixer Left (Mixer 1) Control 1 Register

| Bits | Bit Name | Description | |
|-------|--------------|--|-----------------------------|
| [4:3] | LDBOOST[1:0] | Left channel differential PGA input gain boost, input to Mixer 1. The left differential input uses the LINP (positive signal) and LINN (negative signal) pins. | |
| | | Setting | Gain Boost |
| | | 00 | Mute (default) |
| | | 01 | 0 dB |
| | | 10 | 20 dB |
| | 11 | Reserved | |
| [2:0] | MX1AUXG[2:0] | Left single-ended auxiliary input gain from the LAUX pin in the record path, input to Mixer 1. | |
| | | Setting | Auxiliary Input Gain |
| | | 000 | Mute (default) |
| | | 001 | -12 dB |
| | | 010 | -9 dB |
| | | 011 | -6 dB |
| | | 100 | -3 dB |
| | | 101 | 0 dB |
| | | 110 | 3 dB |
| 111 | 6 dB | | |

R6: Record Mixer Right (Mixer 2) Control 0, 16,396 (0x400C)

This register controls the gain of single-ended inputs for the right channel record path. The right channel record mixer is referred to as Mixer 2.

| Bit 7 | Bit 6 | Bit 5 | Bit 4 | Bit 3 | Bit 2 | Bit 1 | Bit 0 |
|----------|------------|-------|-------|------------|-------|-------|-------|
| Reserved | RINPG[2:0] | | | RINNG[2:0] | | | MX2EN |

Table 40. Record Mixer Right (Mixer 2) Control 0 Register

| Bits | Bit Name | Description | |
|-------|------------|---|----------------|
| [6:4] | RINPG[2:0] | Gain for a right channel single-ended input from the RINP pin, input to Mixer 2. | |
| | | Setting | Gain |
| | | 000 | Mute (default) |
| | | 001 | -12 dB |
| | | 010 | -9 dB |
| | | 011 | -6 dB |
| | | 100 | -3 dB |
| | | 101 | 0 dB |
| | | 110 | 3 dB |
| | | 111 | 6 dB |
| [3:1] | RINNG[2:0] | Gain for a right channel single-ended input from the RINN pin, input to Mixer 2. | |
| | | Setting | Gain |
| | | 000 | Mute (default) |
| | | 001 | -12 dB |
| | | 010 | -9 dB |
| | | 011 | -6 dB |
| | | 100 | -3 dB |
| | | 101 | 0 dB |
| | | 110 | 3 dB |
| | | 111 | 6 dB |
| 0 | MX2EN | Right channel mixer enable in the record path. Referred to as Mixer 2. 0 = mixer disabled (default). 1 = mixer enabled. | |

R7: Record Mixer Right (Mixer 2) Control 1, 16,397 (0x400D)

This register controls the gain boost of the right channel differential PGA input and the gain for the right channel auxiliary input in the record path. The right channel record mixer is referred to as Mixer 2.

| Bit 7 | Bit 6 | Bit 5 | Bit 4 | Bit 3 | Bit 2 | Bit 1 | Bit 0 |
|----------|-------|-------|--------------|-------|--------------|-------|-------|
| Reserved | | | RDBOOST[1:0] | | MX2AUXG[2:0] | | |

Table 41. Record Mixer Right (Mixer 2) Control 1 Register

| Bits | Bit Name | Description | |
|-------|--------------|--|-----------------------------|
| [4:3] | RDBOOST[1:0] | Right channel differential PGA input gain boost, input to Mixer 2. The right differential input uses the RINP (positive signal) and RINN (negative signal) pins. | |
| | | Setting | Gain Boost |
| | | 00 | Mute (default) |
| | | 01 | 0 dB |
| | | 10 | 20 dB |
| | | 11 | Reserved |
| [2:0] | MX2AUXG[2:0] | Right single-ended auxiliary input gain from the RAUX pin in the record path, input to Mixer 2. | |
| | | Setting | Auxiliary Input Gain |
| | | 000 | Mute (default) |
| | | 001 | -12 dB |
| | | 010 | -9 dB |
| | | 011 | -6 dB |
| | | 100 | -3 dB |
| | | 101 | 0 dB |
| | | 110 | 3 dB |
| | | 111 | 6 dB |

R8: Left Differential Input Volume Control, 16,398 (0x400E)

This register enables the differential path and sets the volume control for the left differential PGA input.

| Bit 7 | Bit 6 | Bit 5 | Bit 4 | Bit 3 | Bit 2 | Bit 1 | Bit 0 |
|------------|-------|-------|-------|-------|-------|--------|-------|
| LDVOL[5:0] | | | | | | LDMUTE | LDEN |

Table 42. Left Differential Input Volume Control Register

| Bits | Bit Name | Description | |
|-------|------------|---|------------------|
| [7:2] | LDVOL[5:0] | Left channel differential PGA input volume control. The left differential input uses the LINP (positive signal) and LINN (negative signal) pins. Each step corresponds to a 0.75 dB increase in gain. See Table 92 for a complete list of the volume settings. | |
| | | Setting | Volume |
| | | 000000 | -12 dB (default) |
| | | 000001 | -11.25 dB |
| | | ... | ... |
| | | 010000 | 0 dB |
| | | ... | ... |
| | | 111110 | 34.5 dB |
| | | 111111 | 35.25 dB |
| | | 1 | LDMUTE |
| 0 | LDEN | Left differential PGA enable. When enabled, the LINP and LINN pins are used as a full differential pair. When disabled, these two pins are configured as two single-ended inputs with the signals routed around the PGA. 0 = disabled (default). 1 = enabled. | |

R9: Right Differential Input Volume Control, 16,399 (0x400F)

This register enables the differential path and sets the volume control for the right differential PGA input.

| Bit 7 | Bit 6 | Bit 5 | Bit 4 | Bit 3 | Bit 2 | Bit 1 | Bit 0 |
|------------|-------|-------|-------|-------|-------|--------|-------|
| RDVOL[5:0] | | | | | | RDMUTE | RDEN |

Table 43. Right Differential Input Volume Control Register

| Bits | Bit Name | Description | | | | | | | | | | | | | | | | |
|---------|------------------|--|---------|--------|--------|------------------|--------|-----------|-----|-----|--------|------|-----|-----|--------|---------|--------|----------|
| [7:2] | RDVOL[5:0] | Right channel differential PGA input volume control. The right differential input uses the RINP (positive signal) and RINN (negative signal) pins. Each step corresponds to a 0.75 dB increase in gain. See Table 92 for a complete list of the volume settings. <table border="1" style="width: 100%; margin-top: 5px;"> <thead> <tr> <th>Setting</th> <th>Volume</th> </tr> </thead> <tbody> <tr> <td>000000</td> <td>-12 dB (default)</td> </tr> <tr> <td>000001</td> <td>-11.25 dB</td> </tr> <tr> <td>...</td> <td>...</td> </tr> <tr> <td>010000</td> <td>0 dB</td> </tr> <tr> <td>...</td> <td>...</td> </tr> <tr> <td>111110</td> <td>34.5 dB</td> </tr> <tr> <td>111111</td> <td>35.25 dB</td> </tr> </tbody> </table> | Setting | Volume | 000000 | -12 dB (default) | 000001 | -11.25 dB | ... | ... | 010000 | 0 dB | ... | ... | 111110 | 34.5 dB | 111111 | 35.25 dB |
| Setting | Volume | | | | | | | | | | | | | | | | | |
| 000000 | -12 dB (default) | | | | | | | | | | | | | | | | | |
| 000001 | -11.25 dB | | | | | | | | | | | | | | | | | |
| ... | ... | | | | | | | | | | | | | | | | | |
| 010000 | 0 dB | | | | | | | | | | | | | | | | | |
| ... | ... | | | | | | | | | | | | | | | | | |
| 111110 | 34.5 dB | | | | | | | | | | | | | | | | | |
| 111111 | 35.25 dB | | | | | | | | | | | | | | | | | |
| 1 | RDMUTE | Right differential input mute control. 0 = mute (default). 1 = unmute. | | | | | | | | | | | | | | | | |
| 0 | RDEN | Right differential PGA enable. When enabled, the RINP and RINN pins are used as a full differential pair. When disabled, these two pins are configured as two single-ended inputs with the signals routed around the PGA. 0 = disabled (default). 1 = enabled. | | | | | | | | | | | | | | | | |

R10: Record Microphone Bias Control, 16,400 (0x4010)

This register controls the MICBIAS pin settings for biasing electret type analog microphones.

| Bit 7 | Bit 6 | Bit 5 | Bit 4 | Bit 3 | Bit 2 | Bit 1 | Bit 0 |
|----------|-------|-------|-------|-------|-------|----------|-------|
| Reserved | | | | MPERF | MBI | Reserved | MBIEN |

Table 44. Record Microphone Bias Control Register

| Bits | Bit Name | Description |
|------|----------|---|
| 3 | MPERF | Microphone bias is enabled for high performance or normal operation. High performance operation sources more current to the microphone. 0 = normal operation (default). 1 = high performance. |
| 2 | MBI | Microphone voltage bias as a fraction of AVDD. 0 = 0.90 × AVDD (default). 1 = 0.65 × AVDD. |
| 0 | MBIEN | Enables the MICBIAS output. 0 = disabled (default). 1 = enabled. |

R11: ALC Control 0, 16,401 (0x4011)

| Bit 7 | Bit 6 | Bit 5 | Bit 4 | Bit 3 | Bit 2 | Bit 1 | Bit 0 |
|--------------|-------|-------------|-------|-------|-------------|-------|-------|
| PGASLEW[1:0] | | ALCMAX[2:0] | | | ALCSEL[2:0] | | |

Table 45. ALC Control 0 Register

| Bits | Bit Name | Description | |
|-------|--------------|--|-------------------------|
| [7:6] | PGASLEW[1:0] | PGA volume slew time when the ALC is off. The slew time is the period of time that a volume increase or decrease takes to ramp up or ramp down to the target volume set in Register R8 (left differential input volume control) and Register R9 (right differential input volume control). | |
| | | Setting | Slew Time |
| | | 00 | 24 ms (default) |
| | | 01 | 48 ms |
| | | 10 11 | 96 ms Off |
| [5:3] | ALCMAX[2:0] | The maximum ALC gain sets a limit to the amount of gain that the ALC can provide to the input signal. This protects small signals from excessive amplification. | |
| | | Setting | Maximum ALC Gain |
| | | 000 | -12 dB (default) |
| | | 001 | -6 dB |
| | | 010 | 0 dB |
| | | 011 | 6 dB |
| | | 100 | 12 dB |
| | | 101 | 18 dB |
| | | 110 111 | 24 dB 30 dB |
| [2:0] | ALCSEL[2:0] | ALC select. These bits set the channels that are controlled by the ALC. When set to right only, the ALC responds only to the right channel input and controls the gain of the right PGA amplifier only. When set to left only, the ALC responds only to the left channel input and controls the gain of the left PGA amplifier only. When set to stereo, the ALC responds to the greater of the left or right channel and controls the gain of both the left and right PGA amplifiers. DSP control allows the PGA gain to be set within the DSP or from external GPIO inputs. These bits must be off if manual control of the volume is desired. | |
| | | Setting | Channels |
| | | 000 | Off (default) |
| | | 001 | Right only |
| | | 010 | Left only |
| | | 011 | Stereo |
| | | 100 | DSP control |
| | | 101 | Reserved |
| | | 110 111 | Reserved Reserved |

R12: ALC Control 1, 16,402 (0x4012)

| | | | | | | | |
|--------------|--------------|--------------|--------------|--------------|--------------|--------------|--------------|
| Bit 7 | Bit 6 | Bit 5 | Bit 4 | Bit 3 | Bit 2 | Bit 1 | Bit 0 |
| ALCHOLD[3:0] | | | | ALCTARG[3:0] | | | |

Table 46. ALC Control 1 Register

| Bits | Bit Name | Description | | | | | | | | | | | | | | | | | | | | | | | | | | | | | | | | | | |
|----------------|--------------------|--|----------------|-------------------|------|--------------------|------|---------|------|----------|------|----------|------|----------|------|----------|------|-----------|------|-----------|------|-----------|------|-----------|------|------------|------|------------|------|------------|------|------------|------|------------|------|------------|
| [7:4] | ALCHOLD[3:0] | ALC hold time. The ALC hold time is the amount of time that the ALC waits after a decrease in input level before increasing the gain to achieve the target level. The recommended minimum setting is 21 ms (0011) to prevent distortion of low frequency signals. The hold time doubles with every 1-bit increase. | | | | | | | | | | | | | | | | | | | | | | | | | | | | | | | | | | |
| | | <table border="1"> <thead> <tr> <th>Setting</th> <th>Hold Time</th> </tr> </thead> <tbody> <tr><td>0000</td><td>2.67 ms (default)</td></tr> <tr><td>0001</td><td>5.34 ms</td></tr> <tr><td>0010</td><td>10.68 ms</td></tr> <tr><td>0011</td><td>21.36 ms</td></tr> <tr><td>0100</td><td>42.72 ms</td></tr> <tr><td>0101</td><td>85.44 ms</td></tr> <tr><td>0110</td><td>170.88 ms</td></tr> <tr><td>0111</td><td>341.76 ms</td></tr> <tr><td>1000</td><td>683.52 ms</td></tr> <tr><td>1001</td><td>1.367 sec</td></tr> <tr><td>1010</td><td>2.7341 sec</td></tr> <tr><td>1011</td><td>5.4682 sec</td></tr> <tr><td>1100</td><td>10.936 sec</td></tr> <tr><td>1101</td><td>21.873 sec</td></tr> <tr><td>1110</td><td>43.745 sec</td></tr> <tr><td>1111</td><td>87.491 sec</td></tr> </tbody> </table> | Setting | Hold Time | 0000 | 2.67 ms (default) | 0001 | 5.34 ms | 0010 | 10.68 ms | 0011 | 21.36 ms | 0100 | 42.72 ms | 0101 | 85.44 ms | 0110 | 170.88 ms | 0111 | 341.76 ms | 1000 | 683.52 ms | 1001 | 1.367 sec | 1010 | 2.7341 sec | 1011 | 5.4682 sec | 1100 | 10.936 sec | 1101 | 21.873 sec | 1110 | 43.745 sec | 1111 | 87.491 sec |
| Setting | Hold Time | | | | | | | | | | | | | | | | | | | | | | | | | | | | | | | | | | | |
| 0000 | 2.67 ms (default) | | | | | | | | | | | | | | | | | | | | | | | | | | | | | | | | | | | |
| 0001 | 5.34 ms | | | | | | | | | | | | | | | | | | | | | | | | | | | | | | | | | | | |
| 0010 | 10.68 ms | | | | | | | | | | | | | | | | | | | | | | | | | | | | | | | | | | | |
| 0011 | 21.36 ms | | | | | | | | | | | | | | | | | | | | | | | | | | | | | | | | | | | |
| 0100 | 42.72 ms | | | | | | | | | | | | | | | | | | | | | | | | | | | | | | | | | | | |
| 0101 | 85.44 ms | | | | | | | | | | | | | | | | | | | | | | | | | | | | | | | | | | | |
| 0110 | 170.88 ms | | | | | | | | | | | | | | | | | | | | | | | | | | | | | | | | | | | |
| 0111 | 341.76 ms | | | | | | | | | | | | | | | | | | | | | | | | | | | | | | | | | | | |
| 1000 | 683.52 ms | | | | | | | | | | | | | | | | | | | | | | | | | | | | | | | | | | | |
| 1001 | 1.367 sec | | | | | | | | | | | | | | | | | | | | | | | | | | | | | | | | | | | |
| 1010 | 2.7341 sec | | | | | | | | | | | | | | | | | | | | | | | | | | | | | | | | | | | |
| 1011 | 5.4682 sec | | | | | | | | | | | | | | | | | | | | | | | | | | | | | | | | | | | |
| 1100 | 10.936 sec | | | | | | | | | | | | | | | | | | | | | | | | | | | | | | | | | | | |
| 1101 | 21.873 sec | | | | | | | | | | | | | | | | | | | | | | | | | | | | | | | | | | | |
| 1110 | 43.745 sec | | | | | | | | | | | | | | | | | | | | | | | | | | | | | | | | | | | |
| 1111 | 87.491 sec | | | | | | | | | | | | | | | | | | | | | | | | | | | | | | | | | | | |
| [3:0] | ALCTARG[3:0] | ALC target. The ALC target sets the desired ADC input level. The PGA gain is adjusted by the ALC to reach this target level. The recommended target level is between -16 dB and -10 dB to accommodate transients without clipping the ADC. | | | | | | | | | | | | | | | | | | | | | | | | | | | | | | | | | | |
| | | <table border="1"> <thead> <tr> <th>Setting</th> <th>ALC Target</th> </tr> </thead> <tbody> <tr><td>0000</td><td>-28.5 dB (default)</td></tr> <tr><td>0001</td><td>-27 dB</td></tr> <tr><td>0010</td><td>-25.5 dB</td></tr> <tr><td>0011</td><td>-24 dB</td></tr> <tr><td>0100</td><td>-22.5 dB</td></tr> <tr><td>0101</td><td>-21 dB</td></tr> <tr><td>0110</td><td>-19.5 dB</td></tr> <tr><td>0111</td><td>-18 dB</td></tr> <tr><td>1000</td><td>-16.5 dB</td></tr> <tr><td>1001</td><td>-15 dB</td></tr> <tr><td>1010</td><td>-13.5 dB</td></tr> <tr><td>1011</td><td>-12 dB</td></tr> <tr><td>1100</td><td>-10.5 dB</td></tr> <tr><td>1101</td><td>-9 dB</td></tr> <tr><td>1110</td><td>-7.5 dB</td></tr> <tr><td>1111</td><td>-6 dB</td></tr> </tbody> </table> | Setting | ALC Target | 0000 | -28.5 dB (default) | 0001 | -27 dB | 0010 | -25.5 dB | 0011 | -24 dB | 0100 | -22.5 dB | 0101 | -21 dB | 0110 | -19.5 dB | 0111 | -18 dB | 1000 | -16.5 dB | 1001 | -15 dB | 1010 | -13.5 dB | 1011 | -12 dB | 1100 | -10.5 dB | 1101 | -9 dB | 1110 | -7.5 dB | 1111 | -6 dB |
| Setting | ALC Target | | | | | | | | | | | | | | | | | | | | | | | | | | | | | | | | | | | |
| 0000 | -28.5 dB (default) | | | | | | | | | | | | | | | | | | | | | | | | | | | | | | | | | | | |
| 0001 | -27 dB | | | | | | | | | | | | | | | | | | | | | | | | | | | | | | | | | | | |
| 0010 | -25.5 dB | | | | | | | | | | | | | | | | | | | | | | | | | | | | | | | | | | | |
| 0011 | -24 dB | | | | | | | | | | | | | | | | | | | | | | | | | | | | | | | | | | | |
| 0100 | -22.5 dB | | | | | | | | | | | | | | | | | | | | | | | | | | | | | | | | | | | |
| 0101 | -21 dB | | | | | | | | | | | | | | | | | | | | | | | | | | | | | | | | | | | |
| 0110 | -19.5 dB | | | | | | | | | | | | | | | | | | | | | | | | | | | | | | | | | | | |
| 0111 | -18 dB | | | | | | | | | | | | | | | | | | | | | | | | | | | | | | | | | | | |
| 1000 | -16.5 dB | | | | | | | | | | | | | | | | | | | | | | | | | | | | | | | | | | | |
| 1001 | -15 dB | | | | | | | | | | | | | | | | | | | | | | | | | | | | | | | | | | | |
| 1010 | -13.5 dB | | | | | | | | | | | | | | | | | | | | | | | | | | | | | | | | | | | |
| 1011 | -12 dB | | | | | | | | | | | | | | | | | | | | | | | | | | | | | | | | | | | |
| 1100 | -10.5 dB | | | | | | | | | | | | | | | | | | | | | | | | | | | | | | | | | | | |
| 1101 | -9 dB | | | | | | | | | | | | | | | | | | | | | | | | | | | | | | | | | | | |
| 1110 | -7.5 dB | | | | | | | | | | | | | | | | | | | | | | | | | | | | | | | | | | | |
| 1111 | -6 dB | | | | | | | | | | | | | | | | | | | | | | | | | | | | | | | | | | | |

R13: ALC Control 2, 16,403 (0x4013)

| | | | | | | | |
|--------------|-------|-------|-------|-------------|-------|-------|-------|
| Bit 7 | Bit 6 | Bit 5 | Bit 4 | Bit 3 | Bit 2 | Bit 1 | Bit 0 |
| ALCATCK[3:0] | | | | ALCDEC[3:0] | | | |

Table 47. ALC Control 2 Register

| Bits | Bit Name | Description | | | | | | | | | | | | | | | | | | | | | | | | | | | | | | | | | | |
|---------|----------------|--|---------|-------------|------|----------------|------|-------|------|-------|------|--------|------|--------|------|--------|------|----------|------|----------|------|----------|------|-----------|------|-----------|------|-----------|------|-----------|------|------------|------|------------|------|------------|
| [7:4] | ALCATCK[3:0] | ALC attack time. The attack time sets how fast the ALC starts attenuating after an increase in input level above the target. A typical setting for music recording is 384 ms, and a typical setting for voice recording is 24 ms. | | | | | | | | | | | | | | | | | | | | | | | | | | | | | | | | | | |
| | | <table border="1"> <thead> <tr> <th>Setting</th> <th>Attack Time</th> </tr> </thead> <tbody> <tr><td>0000</td><td>6 ms (default)</td></tr> <tr><td>0001</td><td>12 ms</td></tr> <tr><td>0010</td><td>24 ms</td></tr> <tr><td>0011</td><td>48 ms</td></tr> <tr><td>0100</td><td>96 ms</td></tr> <tr><td>0101</td><td>192 ms</td></tr> <tr><td>0110</td><td>384 ms</td></tr> <tr><td>0111</td><td>768 ms</td></tr> <tr><td>1000</td><td>1.54 sec</td></tr> <tr><td>1001</td><td>3.07 sec</td></tr> <tr><td>1010</td><td>6.14 sec</td></tr> <tr><td>1011</td><td>12.29 sec</td></tr> <tr><td>1100</td><td>24.58 sec</td></tr> <tr><td>1101</td><td>49.15 sec</td></tr> <tr><td>1110</td><td>98.30 sec</td></tr> <tr><td>1111</td><td>196.61 sec</td></tr> </tbody> </table> | Setting | Attack Time | 0000 | 6 ms (default) | 0001 | 12 ms | 0010 | 24 ms | 0011 | 48 ms | 0100 | 96 ms | 0101 | 192 ms | 0110 | 384 ms | 0111 | 768 ms | 1000 | 1.54 sec | 1001 | 3.07 sec | 1010 | 6.14 sec | 1011 | 12.29 sec | 1100 | 24.58 sec | 1101 | 49.15 sec | 1110 | 98.30 sec | 1111 | 196.61 sec |
| Setting | Attack Time | | | | | | | | | | | | | | | | | | | | | | | | | | | | | | | | | | | |
| 0000 | 6 ms (default) | | | | | | | | | | | | | | | | | | | | | | | | | | | | | | | | | | | |
| 0001 | 12 ms | | | | | | | | | | | | | | | | | | | | | | | | | | | | | | | | | | | |
| 0010 | 24 ms | | | | | | | | | | | | | | | | | | | | | | | | | | | | | | | | | | | |
| 0011 | 48 ms | | | | | | | | | | | | | | | | | | | | | | | | | | | | | | | | | | | |
| 0100 | 96 ms | | | | | | | | | | | | | | | | | | | | | | | | | | | | | | | | | | | |
| 0101 | 192 ms | | | | | | | | | | | | | | | | | | | | | | | | | | | | | | | | | | | |
| 0110 | 384 ms | | | | | | | | | | | | | | | | | | | | | | | | | | | | | | | | | | | |
| 0111 | 768 ms | | | | | | | | | | | | | | | | | | | | | | | | | | | | | | | | | | | |
| 1000 | 1.54 sec | | | | | | | | | | | | | | | | | | | | | | | | | | | | | | | | | | | |
| 1001 | 3.07 sec | | | | | | | | | | | | | | | | | | | | | | | | | | | | | | | | | | | |
| 1010 | 6.14 sec | | | | | | | | | | | | | | | | | | | | | | | | | | | | | | | | | | | |
| 1011 | 12.29 sec | | | | | | | | | | | | | | | | | | | | | | | | | | | | | | | | | | | |
| 1100 | 24.58 sec | | | | | | | | | | | | | | | | | | | | | | | | | | | | | | | | | | | |
| 1101 | 49.15 sec | | | | | | | | | | | | | | | | | | | | | | | | | | | | | | | | | | | |
| 1110 | 98.30 sec | | | | | | | | | | | | | | | | | | | | | | | | | | | | | | | | | | | |
| 1111 | 196.61 sec | | | | | | | | | | | | | | | | | | | | | | | | | | | | | | | | | | | |
| [3:0] | ALCDEC[3:0] | ALC decay time. The decay time sets how fast the ALC increases the PGA gain after a decrease in input level below the target. A typical setting for music recording is 24.58 seconds, and a typical setting for voice recording is 1.54 seconds. | | | | | | | | | | | | | | | | | | | | | | | | | | | | | | | | | | |
| | | <table border="1"> <thead> <tr> <th>Setting</th> <th>Decay Time</th> </tr> </thead> <tbody> <tr><td>0000</td><td>24 ms</td></tr> <tr><td>0001</td><td>48 ms</td></tr> <tr><td>0010</td><td>96 ms</td></tr> <tr><td>0011</td><td>192 ms</td></tr> <tr><td>0100</td><td>384 ms</td></tr> <tr><td>0101</td><td>768 ms</td></tr> <tr><td>0110</td><td>1.54 sec</td></tr> <tr><td>0111</td><td>3.07 sec</td></tr> <tr><td>1000</td><td>6.14 sec</td></tr> <tr><td>1001</td><td>12.29 sec</td></tr> <tr><td>1010</td><td>24.58 sec</td></tr> <tr><td>1011</td><td>49.15 sec</td></tr> <tr><td>1100</td><td>98.30 sec</td></tr> <tr><td>1101</td><td>196.61 sec</td></tr> <tr><td>1110</td><td>393.22 sec</td></tr> <tr><td>1111</td><td>786.43 sec</td></tr> </tbody> </table> | Setting | Decay Time | 0000 | 24 ms | 0001 | 48 ms | 0010 | 96 ms | 0011 | 192 ms | 0100 | 384 ms | 0101 | 768 ms | 0110 | 1.54 sec | 0111 | 3.07 sec | 1000 | 6.14 sec | 1001 | 12.29 sec | 1010 | 24.58 sec | 1011 | 49.15 sec | 1100 | 98.30 sec | 1101 | 196.61 sec | 1110 | 393.22 sec | 1111 | 786.43 sec |
| Setting | Decay Time | | | | | | | | | | | | | | | | | | | | | | | | | | | | | | | | | | | |
| 0000 | 24 ms | | | | | | | | | | | | | | | | | | | | | | | | | | | | | | | | | | | |
| 0001 | 48 ms | | | | | | | | | | | | | | | | | | | | | | | | | | | | | | | | | | | |
| 0010 | 96 ms | | | | | | | | | | | | | | | | | | | | | | | | | | | | | | | | | | | |
| 0011 | 192 ms | | | | | | | | | | | | | | | | | | | | | | | | | | | | | | | | | | | |
| 0100 | 384 ms | | | | | | | | | | | | | | | | | | | | | | | | | | | | | | | | | | | |
| 0101 | 768 ms | | | | | | | | | | | | | | | | | | | | | | | | | | | | | | | | | | | |
| 0110 | 1.54 sec | | | | | | | | | | | | | | | | | | | | | | | | | | | | | | | | | | | |
| 0111 | 3.07 sec | | | | | | | | | | | | | | | | | | | | | | | | | | | | | | | | | | | |
| 1000 | 6.14 sec | | | | | | | | | | | | | | | | | | | | | | | | | | | | | | | | | | | |
| 1001 | 12.29 sec | | | | | | | | | | | | | | | | | | | | | | | | | | | | | | | | | | | |
| 1010 | 24.58 sec | | | | | | | | | | | | | | | | | | | | | | | | | | | | | | | | | | | |
| 1011 | 49.15 sec | | | | | | | | | | | | | | | | | | | | | | | | | | | | | | | | | | | |
| 1100 | 98.30 sec | | | | | | | | | | | | | | | | | | | | | | | | | | | | | | | | | | | |
| 1101 | 196.61 sec | | | | | | | | | | | | | | | | | | | | | | | | | | | | | | | | | | | |
| 1110 | 393.22 sec | | | | | | | | | | | | | | | | | | | | | | | | | | | | | | | | | | | |
| 1111 | 786.43 sec | | | | | | | | | | | | | | | | | | | | | | | | | | | | | | | | | | | |

R14: ALC Control 3, 16,404 (0x4014)

| | | | | | | | |
|--------------|--------------|--------------|--------------|--------------|--------------|--------------|--------------|
| Bit 7 | Bit 6 | Bit 5 | Bit 4 | Bit 3 | Bit 2 | Bit 1 | Bit 0 |
| NGTYP[1:0] | | NGEN | NGTHR[4:0] | | | | |

Table 48. ALC Control 3 Register

| Bits | Bit Name | Description | |
|-------|------------|--|---|
| [7:6] | NGTYP[1:0] | Noise gate type. When the input signal falls below the threshold for 250 ms, the noise gate can hold a constant PGA gain, mute the ADC output, fade the PGA gain to the minimum gain value, or fade then mute. | |
| | | Setting | Noise Gate |
| | | 00 | Hold PGA constant (default) |
| | | 01 | Mute ADC output (digital mute) |
| | | 10 | Fade to PGA minimum value (analog fade) |
| | | 11 | Fade then mute (analog fade/digital mute) |
| 5 | NGEN | Noise gate enable. 0 = disabled (default). 1 = enabled. | |
| [4:0] | NGTHR[4:0] | Noise gate threshold. When the input signal falls below the threshold for 250 ms, the noise gate is activated. A 1 LSB increase corresponds to a -1.5 dB change. See Table 93 for a complete list of the threshold settings. | |
| | | Setting | Threshold |
| | | 00000 | -76.5 dB (default) |
| | | 00001 | -75 dB |
| | | ... | ... |
| | | 11110 | -31.5 dB |
| | | 11111 | -30 dB |

R15: Serial Port Control 0, 16,405 (0x4015)

| | | | | | | | |
|--------------|--------------|--------------|--------------|--------------|--------------|--------------|--------------|
| Bit 7 | Bit 6 | Bit 5 | Bit 4 | Bit 3 | Bit 2 | Bit 1 | Bit 0 |
| Reserved | SPSRS | LRMOD | BPOL | LRPOL | CHPF[1:0] | | MS |

Table 49. Serial Port Control 0 Register

| Bits | Bit Name | Description | |
|-------|-----------|---|---------------------------------|
| 6 | SPSRS | Serial port sampling rate source. 0 = converter rate set in Register R17 (default). 1 = DSP rate set in Register R57. | |
| 5 | LRMOD | LRCLK mode sets the LRCLK for either a 50% duty cycle or a pulse. The pulse mode should be at least 1 BCLK wide. 0 = 50% duty cycle (default). 1 = pulse mode. | |
| 4 | BPOL | BCLK polarity sets the BCLK edge that triggers a change in audio data. This can be set for the falling or rising edge of the BCLK. 0 = falling edge (default). 1 = rising edge. | |
| 3 | LRPOL | LRCLK polarity sets the LRCLK edge that triggers the beginning of the left channel audio frame. This can be set for the falling or rising edge of the LRCLK. 0 = falling edge (default). 1 = rising edge. | |
| [2:1] | CHPF[1:0] | Channels per frame sets the number of channels per LRCLK frame. | |
| | | Setting | Channels per LRCLK Frame |
| | | 00 | Stereo (default) |
| | | 01 | TDM 4 |
| | | 10 | TDM 8 |
| | | 11 | Reserved |
| 0 | MS | Serial data port bus mode. Both LRCLK and BCLK are master of the serial port when set in master mode and are serial port slave in slave mode. 0 = slave mode (default). 1 = master mode. | |

R16: Serial Port Control 1, 16,406 (0x4016)

| Bit 7 | Bit 6 | Bit 5 | Bit 4 | Bit 3 | Bit 2 | Bit 1 | Bit 0 |
|----------|-------|-------|-------|-------|-------|------------|-------|
| BPF[2:0] | | | ADTDM | DATDM | MSBP | LRDEL[1:0] | |

Table 50. Serial Port Control 1 Register

| Bits | Bit Name | Description | |
|-------|------------|--|---------------------------------|
| [7:5] | BPF[2:0] | Number of bit clock cycles per LRCLK audio frame. | |
| | | Setting | Bit Clock Cycles |
| | | 000 | 64 (default) |
| | | 001 | Reserved |
| | | 010 | 48 |
| | | 011 | 128 |
| | | 100 | 256 |
| | | 101 | Reserved |
| 110 | Reserved | | |
| 111 | Reserved | | |
| 4 | ADTDM | ADC serial audio data channel position in TDM mode. 0 = left first (default). 1 = right first. | |
| 3 | DATDM | DAC serial audio data channel position in TDM mode. 0 = left first (default). 1 = right first. | |
| 2 | MSBP | MSB position in the LRCLK frame. 0 = MSB first (default). 1 = LSB first. | |
| [1:0] | LRDEL[1:0] | Data delay from LRCLK edge (in BCLK units). | |
| | | Setting | Delay (Bit Clock Cycles) |
| | | 00 | 1 (default) |
| | | 01 | 0 |
| | | 10 | 8 |
| 11 | 16 | | |

R17: Converter Control 0, 16,407 (0x4017)

| Bit 7 | Bit 6 | Bit 5 | Bit 4 | Bit 3 | Bit 2 | Bit 1 | Bit 0 |
|----------|-------------|-------|-------|-------|-------------|-------|-------|
| Reserved | DAPAIR[1:0] | | DAOSR | ADOSR | CONVSR[2:0] | | |

Table 51. Converter Control 0 Register

| Bits | Bit Name | Description | | |
|-------|-------------|--|----------------------|---|
| [6:5] | DAPAIR[1:0] | On-chip DAC serial data selection in TDM 4 or TDM 8 mode. | | |
| | | Setting | Pair | |
| | | 00 | First pair (default) | |
| | | 01 | Second pair | |
| | | 10 | Third pair | |
| | 11 | Fourth pair | | |
| 4 | DAOSR | DAC oversampling ratio. This bit cannot be set for 64x when CONVSR[2:0] is set to 96 kHz. 0 = 128x (default). 1 = 64x. | | |
| 3 | ADOSR | ADC oversampling ratio. This bit cannot be set for 64x when CONVSR[2:0] is set to 96 kHz. 0 = 128x (default). 1 = 64x. | | |
| [2:0] | CONVSR[2:0] | Converter sampling rate. The ADCs and DACs operate at the sampling rate set in this register. The converter rate selected is a ratio of the base sampling rate, f_s . The base sampling rate is determined by the operating frequency of the core clock. | | |
| | | Setting | Sampling Rate | Base Sampling Rate ($f_s = 48$ kHz) |
| | | 000 | f_s | 48 kHz, base (default) |
| | | 001 | $f_s/6$ | 8 kHz |
| | | 010 | $f_s/4$ | 12 kHz |
| | | 011 | $f_s/3$ | 16 kHz |
| | | 100 | $f_s/2$ | 24 kHz |
| | | 101 | $f_s/1.5$ | 32 kHz |
| | | 110 | $f_s/0.5$ | 96 kHz |
| | | 111 | Reserved | |

R18: Converter Control 1, 16,408 (0x4018)

| Bit 7 | Bit 6 | Bit 5 | Bit 4 | Bit 3 | Bit 2 | Bit 1 | Bit 0 |
|----------|-------|-------|-------|-------|-------|-------------|-------|
| Reserved | | | | | | ADPAIR[1:0] | |

Table 52. Converter Control 1 Register

| Bits | Bit Name | Description | |
|-------|-------------|---|----------------------|
| [1:0] | ADPAIR[1:0] | On-chip ADC serial data selection in TDM 4 or TDM 8 mode. | |
| | | Setting | Pair |
| | | 00 | First pair (default) |
| | | 01 | Second pair |
| | | 10 | Third pair |
| | 11 | Fourth pair | |

R19: ADC Control, 16,409 (0x4019)

| Bit 7 | Bit 6 | Bit 5 | Bit 4 | Bit 3 | Bit 2 | Bit 1 | Bit 0 |
|----------|--------|-------|-------|-------|-------|------------|-------|
| Reserved | ADCPOL | HPF | DMPOL | DMSW | INSEL | ADCEN[1:0] | |

Table 53. ADC Control Register

| Bits | Bit Name | Description | | | | | | | | | | |
|---------|--------------------|---|---------|--------------|----|--------------------|----|---------|----|----------|----|---------|
| 6 | ADCPOL | Invert input polarity. 0 = normal (default). 1 = inverted. | | | | | | | | | | |
| 5 | HPF | ADC high-pass filter select. At 48 kHz, $f_{3dB} = 2$ Hz. 0 = off (default). 1 = on. | | | | | | | | | | |
| 4 | DMPOL | Digital microphone data polarity swap. 0 = invert polarity. 1 = normal (default). | | | | | | | | | | |
| 3 | DMSW | Digital microphone channel swap. Normal operation sends the left channel on the rising edge of the clock and the right channel on the falling edge of the clock. 0 = normal (default). 1 = swap left and right channels. | | | | | | | | | | |
| 2 | INSEL | Digital microphone input select. When asserted, the on-chip ADCs are off, BCLK is master at $128 \times f_s$, and ADC_SDATA is expected to have left and right channels interleaved. 0 = digital microphone inputs off, ADCs enabled (default). 1 = digital microphone inputs enabled, ADCs off. | | | | | | | | | | |
| [1:0] | ADCEN[1:0] | ADC enable. | | | | | | | | | | |
| | | <table border="1"> <thead> <tr> <th>Setting</th> <th>ADCs Enabled</th> </tr> </thead> <tbody> <tr> <td>00</td> <td>Both off (default)</td> </tr> <tr> <td>01</td> <td>Left on</td> </tr> <tr> <td>10</td> <td>Right on</td> </tr> <tr> <td>11</td> <td>Both on</td> </tr> </tbody> </table> | Setting | ADCs Enabled | 00 | Both off (default) | 01 | Left on | 10 | Right on | 11 | Both on |
| Setting | ADCs Enabled | | | | | | | | | | | |
| 00 | Both off (default) | | | | | | | | | | | |
| 01 | Left on | | | | | | | | | | | |
| 10 | Right on | | | | | | | | | | | |
| 11 | Both on | | | | | | | | | | | |

R20: Left Input Digital Volume, 16,410 (0x401A)

| Bit 7 | Bit 6 | Bit 5 | Bit 4 | Bit 3 | Bit 2 | Bit 1 | Bit 0 |
|-------------|-------|-------|-------|-------|-------|-------|-------|
| LADVOL[7:0] | | | | | | | |

Table 54. Left Input Digital Volume Register

| Bits | Bit Name | Description | | | | | | | | | | | | | | |
|----------|--------------------|---|---------|--------------------|----------|----------------|----------|-----------|----------|----------|-----|-----|----------|-----------|----------|------------|
| [7:0] | LADVOL[7:0] | Controls the digital volume attenuation for left channel inputs from either the left ADC or the left digital microphone input. Each bit corresponds to a 0.375 dB step with slewing between settings. See Table 94 for a complete list of the volume settings. | | | | | | | | | | | | | | |
| | | <table border="1"> <thead> <tr> <th>Setting</th> <th>Volume Attenuation</th> </tr> </thead> <tbody> <tr> <td>00000000</td> <td>0 dB (default)</td> </tr> <tr> <td>00000001</td> <td>-0.375 dB</td> </tr> <tr> <td>00000010</td> <td>-0.75 dB</td> </tr> <tr> <td>...</td> <td>...</td> </tr> <tr> <td>11111110</td> <td>-95.25 dB</td> </tr> <tr> <td>11111111</td> <td>-95.625 dB</td> </tr> </tbody> </table> | Setting | Volume Attenuation | 00000000 | 0 dB (default) | 00000001 | -0.375 dB | 00000010 | -0.75 dB | ... | ... | 11111110 | -95.25 dB | 11111111 | -95.625 dB |
| Setting | Volume Attenuation | | | | | | | | | | | | | | | |
| 00000000 | 0 dB (default) | | | | | | | | | | | | | | | |
| 00000001 | -0.375 dB | | | | | | | | | | | | | | | |
| 00000010 | -0.75 dB | | | | | | | | | | | | | | | |
| ... | ... | | | | | | | | | | | | | | | |
| 11111110 | -95.25 dB | | | | | | | | | | | | | | | |
| 11111111 | -95.625 dB | | | | | | | | | | | | | | | |

R21: Right Input Digital Volume, 16,411 (0x401B)

| | | | | | | | |
|-------------|-------|-------|-------|-------|-------|-------|-------|
| Bit 7 | Bit 6 | Bit 5 | Bit 4 | Bit 3 | Bit 2 | Bit 1 | Bit 0 |
| RADVOL[7:0] | | | | | | | |

Table 55. Right Input Digital Volume Register

| Bits | Bit Name | Description | | | | | | | | | | | | | | |
|----------|--------------------|---|---------|--------------------|----------|----------------|----------|-----------|----------|----------|-----|-----|----------|-----------|----------|------------|
| [7:0] | RADVOL[7:0] | Controls the digital volume attenuation for right channel inputs from either the right ADC or the right digital microphone input. Each bit corresponds to a 0.375 dB step with slewing between settings. See Table 94 for a complete list of the volume settings. | | | | | | | | | | | | | | |
| | | <table border="1"> <thead> <tr> <th>Setting</th> <th>Volume Attenuation</th> </tr> </thead> <tbody> <tr> <td>00000000</td> <td>0 dB (default)</td> </tr> <tr> <td>00000001</td> <td>-0.375 dB</td> </tr> <tr> <td>00000010</td> <td>-0.75 dB</td> </tr> <tr> <td>...</td> <td>...</td> </tr> <tr> <td>11111110</td> <td>-95.25 dB</td> </tr> <tr> <td>11111111</td> <td>-95.625 dB</td> </tr> </tbody> </table> | Setting | Volume Attenuation | 00000000 | 0 dB (default) | 00000001 | -0.375 dB | 00000010 | -0.75 dB | ... | ... | 11111110 | -95.25 dB | 11111111 | -95.625 dB |
| Setting | Volume Attenuation | | | | | | | | | | | | | | | |
| 00000000 | 0 dB (default) | | | | | | | | | | | | | | | |
| 00000001 | -0.375 dB | | | | | | | | | | | | | | | |
| 00000010 | -0.75 dB | | | | | | | | | | | | | | | |
| ... | ... | | | | | | | | | | | | | | | |
| 11111110 | -95.25 dB | | | | | | | | | | | | | | | |
| 11111111 | -95.625 dB | | | | | | | | | | | | | | | |

R22: Playback Mixer Left (Mixer 3) Control 0, 16,412 (0x401C)

| | | | | | | | |
|----------|-------|-------|--------------|-------|-------|-------|-------|
| Bit 7 | Bit 6 | Bit 5 | Bit 4 | Bit 3 | Bit 2 | Bit 1 | Bit 0 |
| Reserved | MX3RM | MX3LM | MX3AUXG[3:0] | | | | MX3EN |

Table 56. Playback Mixer Left (Mixer 3) Control 0 Register

| Bits | Bit Name | Description | | | | | | | | | | | | | | | | | | | | |
|---------|----------------|---|---------|------|------|----------------|------|--------|------|--------|------|-------|------|-------|------|-------|------|------|------|------|------|------|
| 6 | MX3RM | Mixer input mute. Mutes the right DAC input to the left channel playback mixer (Mixer 3). 0 = muted (default). 1 = unmuted. | | | | | | | | | | | | | | | | | | | | |
| 5 | MX3LM | Mixer input mute. Mutes the left DAC input to the left channel playback mixer (Mixer 3). 0 = muted (default). 1 = unmuted. | | | | | | | | | | | | | | | | | | | | |
| [4:1] | MX3AUXG[3:0] | Mixer input gain. Controls the left channel auxiliary input gain to the left channel playback mixer (Mixer 3). | | | | | | | | | | | | | | | | | | | | |
| | | <table border="1"> <thead> <tr> <th>Setting</th> <th>Gain</th> </tr> </thead> <tbody> <tr> <td>0000</td> <td>Mute (default)</td> </tr> <tr> <td>0001</td> <td>-15 dB</td> </tr> <tr> <td>0010</td> <td>-12 dB</td> </tr> <tr> <td>0011</td> <td>-9 dB</td> </tr> <tr> <td>0100</td> <td>-6 dB</td> </tr> <tr> <td>0101</td> <td>-3 dB</td> </tr> <tr> <td>0110</td> <td>0 dB</td> </tr> <tr> <td>0111</td> <td>3 dB</td> </tr> <tr> <td>1000</td> <td>6 dB</td> </tr> </tbody> </table> | Setting | Gain | 0000 | Mute (default) | 0001 | -15 dB | 0010 | -12 dB | 0011 | -9 dB | 0100 | -6 dB | 0101 | -3 dB | 0110 | 0 dB | 0111 | 3 dB | 1000 | 6 dB |
| Setting | Gain | | | | | | | | | | | | | | | | | | | | | |
| 0000 | Mute (default) | | | | | | | | | | | | | | | | | | | | | |
| 0001 | -15 dB | | | | | | | | | | | | | | | | | | | | | |
| 0010 | -12 dB | | | | | | | | | | | | | | | | | | | | | |
| 0011 | -9 dB | | | | | | | | | | | | | | | | | | | | | |
| 0100 | -6 dB | | | | | | | | | | | | | | | | | | | | | |
| 0101 | -3 dB | | | | | | | | | | | | | | | | | | | | | |
| 0110 | 0 dB | | | | | | | | | | | | | | | | | | | | | |
| 0111 | 3 dB | | | | | | | | | | | | | | | | | | | | | |
| 1000 | 6 dB | | | | | | | | | | | | | | | | | | | | | |
| 0 | MX3EN | Mixer 3 enable. 0 = disabled (default). 1 = enabled. | | | | | | | | | | | | | | | | | | | | |

R23: Playback Mixer Left (Mixer 3) Control 1, 16,413 (0x401D)

| | | | | | | | |
|--------------|--------------|--------------|--------------|--------------|--------------|--------------|--------------|
| Bit 7 | Bit 6 | Bit 5 | Bit 4 | Bit 3 | Bit 2 | Bit 1 | Bit 0 |
| MX3G2[3:0] | | | | MX3G1[3:0] | | | |

Table 57. Playback Mixer Left (Mixer 3) Control 1 Register

| Bits | Bit Name | Description | |
|-------------|-----------------|---|----------------|
| [7:4] | MX3G2[3:0] | Bypass gain control. The signal from the right channel record mixer (Mixer 2) bypasses the converters and gain can be applied before the left playback mixer (Mixer 3). | |
| | | Setting | Gain |
| | | 0000 | Mute (default) |
| | | 0001 | -15 dB |
| | | 0010 | -12 dB |
| | | 0011 | -9 dB |
| | | 0100 | -6 dB |
| | | 0101 | -3 dB |
| | | 0110 | 0 dB |
| | | 0111 | 3 dB |
| | | 1000 | 6 dB |
| [3:0] | MX3G1[3:0] | Bypass gain control. The signal from the left channel record mixer (Mixer 1) bypasses the converters and gain can be applied before the left playback mixer (Mixer 3). | |
| | | Setting | Gain |
| | | 0000 | Mute (default) |
| | | 0001 | -15 dB |
| | | 0010 | -12 dB |
| | | 0011 | -9 dB |
| | | 0100 | -6 dB |
| | | 0101 | -3 dB |
| | | 0110 | 0 dB |
| | | 0111 | 3 dB |
| | | 1000 | 6 dB |

R24: Playback Mixer Right (Mixer 4) Control 0, 16,414 (0x401E)

| Bit 7 | Bit 6 | Bit 5 | Bit 4 | Bit 3 | Bit 2 | Bit 1 | Bit 0 |
|----------|-------|-------|--------------|-------|-------|-------|-------|
| Reserved | MX4RM | MX4LM | MX4AUXG[3:0] | | | | MX4EN |

Table 58. Playback Mixer Right (Mixer 4) Control 0 Register

| Bits | Bit Name | Description | | | | | | | | | | | | | | | | | | | | |
|---------|----------------|---|---------|------|------|----------------|------|--------|------|--------|------|-------|------|-------|------|-------|------|------|------|------|------|------|
| 6 | MX4RM | Mixer input mute. Mutes the right DAC input to the right channel playback mixer (Mixer 4). 0 = muted (default). 1 = unmuted. | | | | | | | | | | | | | | | | | | | | |
| 5 | MX4LM | Mixer input mute. Mutes the left DAC input to the right channel playback mixer (Mixer 4). 0 = muted (default). 1 = unmuted. | | | | | | | | | | | | | | | | | | | | |
| [4:1] | MX4AUXG[3:0] | Mixer input gain. Controls the right channel auxiliary input gain to the right channel playback mixer (Mixer 4). | | | | | | | | | | | | | | | | | | | | |
| | | <table border="1"> <thead> <tr> <th>Setting</th> <th>Gain</th> </tr> </thead> <tbody> <tr> <td>0000</td> <td>Mute (default)</td> </tr> <tr> <td>0001</td> <td>-15 dB</td> </tr> <tr> <td>0010</td> <td>-12 dB</td> </tr> <tr> <td>0011</td> <td>-9 dB</td> </tr> <tr> <td>0100</td> <td>-6 dB</td> </tr> <tr> <td>0101</td> <td>-3 dB</td> </tr> <tr> <td>0110</td> <td>0 dB</td> </tr> <tr> <td>0111</td> <td>3 dB</td> </tr> <tr> <td>1000</td> <td>6 dB</td> </tr> </tbody> </table> | Setting | Gain | 0000 | Mute (default) | 0001 | -15 dB | 0010 | -12 dB | 0011 | -9 dB | 0100 | -6 dB | 0101 | -3 dB | 0110 | 0 dB | 0111 | 3 dB | 1000 | 6 dB |
| Setting | Gain | | | | | | | | | | | | | | | | | | | | | |
| 0000 | Mute (default) | | | | | | | | | | | | | | | | | | | | | |
| 0001 | -15 dB | | | | | | | | | | | | | | | | | | | | | |
| 0010 | -12 dB | | | | | | | | | | | | | | | | | | | | | |
| 0011 | -9 dB | | | | | | | | | | | | | | | | | | | | | |
| 0100 | -6 dB | | | | | | | | | | | | | | | | | | | | | |
| 0101 | -3 dB | | | | | | | | | | | | | | | | | | | | | |
| 0110 | 0 dB | | | | | | | | | | | | | | | | | | | | | |
| 0111 | 3 dB | | | | | | | | | | | | | | | | | | | | | |
| 1000 | 6 dB | | | | | | | | | | | | | | | | | | | | | |
| 0 | MX4EN | Mixer 4 enable. 0 = disabled (default). 1 = enabled. | | | | | | | | | | | | | | | | | | | | |

R25: Playback Mixer Right (Mixer 4) Control 1, 16,415 (0x401F)

| | | | | | | | |
|--------------|--------------|--------------|--------------|--------------|--------------|--------------|--------------|
| Bit 7 | Bit 6 | Bit 5 | Bit 4 | Bit 3 | Bit 2 | Bit 1 | Bit 0 |
| MX4G2[3:0] | | | | MX4G1[3:0] | | | |

Table 59. Playback Mixer Right (Mixer 4) Control 1 Register

| Bits | Bit Name | Description | |
|-------------|-----------------|--|----------------|
| [7:4] | MX4G2[3:0] | Bypass gain control. The signal from the right channel record mixer (Mixer 2) bypasses the converters and gain can be applied before the right playback mixer (Mixer 4). | |
| | | Setting | Gain |
| | | 0000 | Mute (default) |
| | | 0001 | -15 dB |
| | | 0010 | -12 dB |
| | | 0011 | -9 dB |
| | | 0100 | -6 dB |
| | | 0101 | -3 dB |
| | | 0110 | 0 dB |
| | | 0111 | 3 dB |
| | | 1000 | 6 dB |
| [3:0] | MX4G1[3:0] | Bypass gain control. The signal from the left channel record mixer (Mixer 1) bypasses the converters and gain can be applied before the right playback mixer (Mixer 4). | |
| | | Setting | Gain |
| | | 0000 | Mute (default) |
| | | 0001 | -15 dB |
| | | 0010 | -12 dB |
| | | 0011 | -9 dB |
| | | 0100 | -6 dB |
| | | 0101 | -3 dB |
| | | 0110 | 0 dB |
| | | 0111 | 3 dB |
| | | 1000 | 6 dB |

R26: Playback L/R Mixer Left (Mixer 5) Line Output Control, 16,416 (0x4020)

| Bit 7 | Bit 6 | Bit 5 | Bit 4 | Bit 3 | Bit 2 | Bit 1 | Bit 0 |
|----------|-------|-------|------------|-------|------------|-------|-------|
| Reserved | | | MX5G4[1:0] | | MX5G3[1:0] | | MX5EN |

Table 60. Playback L/R Mixer Left (Mixer 5) Line Output Control Register

| Bits | Bit Name | Description | |
|-------|------------|---|--|
| [4:3] | MX5G4[1:0] | Mixer input gain boost. The signal from the right channel playback mixer (Mixer 4) can be enabled and boosted in the playback L/R mixer left (Mixer 5). | |
| | | Setting | Gain Boost |
| | | 00 | Mute (default) |
| | | 01 | 0 dB output (–6 dB gain on each of the two inputs) |
| | | 10 | 6 dB output (0 dB gain on each of the two inputs) |
| | 11 | Reserved | |
| [2:1] | MX5G3[1:0] | Mixer input gain boost. The signal from the left channel playback mixer (Mixer 3) can be enabled and boosted in the playback L/R mixer left (Mixer 5). | |
| | | Setting | Gain Boost |
| | | 00 | Mute (default) |
| | | 01 | 0 dB output (–6 dB gain on each of the two inputs) |
| | | 10 | 6 dB output (0 dB gain on each of the two inputs) |
| | 11 | Reserved | |
| 0 | MX5EN | Mixer 5 enable. 0 = disabled (default). 1 = enabled. | |

R27: Playback L/R Mixer Right (Mixer 6) Line Output Control, 16,417 (0x4021)

| Bit 7 | Bit 6 | Bit 5 | Bit 4 | Bit 3 | Bit 2 | Bit 1 | Bit 0 |
|----------|-------|-------|------------|-------|------------|-------|-------|
| Reserved | | | MX6G4[1:0] | | MX6G3[1:0] | | MX6EN |

Table 61. Playback L/R Mixer Right (Mixer 6) Line Output Control Register

| Bits | Bit Name | Description | |
|-------|------------|--|--|
| [4:3] | MX6G4[1:0] | Mixer input gain boost. The signal from the right channel playback mixer (Mixer 4) can be enabled and boosted in the playback L/R mixer right (Mixer 6). | |
| | | Setting | Gain Boost |
| | | 00 | Mute (default) |
| | | 01 | 0 dB output (–6 dB gain on each of the two inputs) |
| | | 10 | 6 dB output (0 dB gain on each of the two inputs) |
| | 11 | Reserved | |
| [2:1] | MX6G3[1:0] | Mixer input gain boost. The signal from the left channel playback mixer (Mixer 3) can be enabled and boosted in the playback L/R mixer right (Mixer 6). | |
| | | Setting | Gain Boost |
| | | 00 | Mute (default) |
| | | 01 | 0 dB output (–6 dB gain on each of the two inputs) |
| | | 10 | 6 dB output (0 dB gain on each of the two inputs) |
| | 11 | Reserved | |
| 0 | MX6EN | Mixer 6 enable. 0 = disabled (default). 1 = enabled. | |

R28: Playback L/R Mixer Mono Output (Mixer 7) Control, 16,418 (0x4022)

| Bit 7 | Bit 6 | Bit 5 | Bit 4 | Bit 3 | Bit 2 | Bit 1 | Bit 0 |
|----------|-------|-------|-------|-------|----------|-------|-------|
| Reserved | | | | | MX7[1:0] | | MX7EN |

Table 62. Playback L/R Mixer Mono Output (Mixer 7) Control Register

| Bits | Bit Name | Description | | | | | | | | | | |
|---------|--|--|---------|------------|----|------------------------------|----|--|----|---|----|----------|
| [2:1] | MX7[1:0] | L/R mono playback mixer (Mixer 7). Mixes the left and right playback mixers (Mixer 3 and Mixer 4) with either a 0 dB or 6 dB gain boost. Additionally, this mixer can operate as a common-mode output, which is used as the virtual ground in a capless headphone configuration. | | | | | | | | | | |
| | | <table border="1"> <thead> <tr> <th>Setting</th> <th>Gain Boost</th> </tr> </thead> <tbody> <tr> <td>00</td> <td>Common-mode output (default)</td> </tr> <tr> <td>01</td> <td>0 dB output (–6 dB gain on each of the two inputs)</td> </tr> <tr> <td>10</td> <td>6 dB output (0 dB gain on each of the two inputs)</td> </tr> <tr> <td>11</td> <td>Reserved</td> </tr> </tbody> </table> | Setting | Gain Boost | 00 | Common-mode output (default) | 01 | 0 dB output (–6 dB gain on each of the two inputs) | 10 | 6 dB output (0 dB gain on each of the two inputs) | 11 | Reserved |
| Setting | Gain Boost | | | | | | | | | | | |
| 00 | Common-mode output (default) | | | | | | | | | | | |
| 01 | 0 dB output (–6 dB gain on each of the two inputs) | | | | | | | | | | | |
| 10 | 6 dB output (0 dB gain on each of the two inputs) | | | | | | | | | | | |
| 11 | Reserved | | | | | | | | | | | |
| 0 | MX7EN | Mixer 7 enable. 0 = disabled (default). 1 = enabled. | | | | | | | | | | |

R29: Playback Headphone Left Volume Control, 16,419 (0x4023)

| Bit 7 | Bit 6 | Bit 5 | Bit 4 | Bit 3 | Bit 2 | Bit 1 | Bit 0 |
|-------------|-------|-------|-------|-------|-------|-------|-------|
| LHPVOL[5:0] | | | | | | LHPM | HPEN |

Table 63. Playback Headphone Left Volume Control Register

| Bits | Bit Name | Description | | | | | | | | | | | | |
|---------|------------------|--|---------|--------|--------|------------------|-----|-----|--------|------|-----|-----|--------|------|
| [7:2] | LHPVOL[5:0] | Headphone volume control for left channel, LHP output. Each 1-bit step corresponds to a 1 dB increase in volume. See Table 95 for a complete list of the volume settings. | | | | | | | | | | | | |
| | | <table border="1"> <thead> <tr> <th>Setting</th> <th>Volume</th> </tr> </thead> <tbody> <tr> <td>000000</td> <td>–57 dB (default)</td> </tr> <tr> <td>...</td> <td>...</td> </tr> <tr> <td>111001</td> <td>0 dB</td> </tr> <tr> <td>...</td> <td>...</td> </tr> <tr> <td>111111</td> <td>6 dB</td> </tr> </tbody> </table> | Setting | Volume | 000000 | –57 dB (default) | ... | ... | 111001 | 0 dB | ... | ... | 111111 | 6 dB |
| Setting | Volume | | | | | | | | | | | | | |
| 000000 | –57 dB (default) | | | | | | | | | | | | | |
| ... | ... | | | | | | | | | | | | | |
| 111001 | 0 dB | | | | | | | | | | | | | |
| ... | ... | | | | | | | | | | | | | |
| 111111 | 6 dB | | | | | | | | | | | | | |
| 1 | LHPM | Headphone mute for left channel, LHP output (active low). 0 = mute. 1 = unmute (default). | | | | | | | | | | | | |
| 0 | HPEN | Headphone volume control enable. Logical OR with the HPMODE bit in Register R30. If either the HPEN bit or the HPMODE bit is set to 1, the headphone output is enabled. 0 = disabled (default). 1 = enabled. | | | | | | | | | | | | |

R30: Playback Headphone Right Volume Control, 16,420 (0x4024)

| | | | | | | | |
|-------------|-------|-------|-------|-------|-------|-------|--------|
| Bit 7 | Bit 6 | Bit 5 | Bit 4 | Bit 3 | Bit 2 | Bit 1 | Bit 0 |
| RHPVOL[5:0] | | | | | | RHPM | HPMODE |

Table 64. Playback Headphone Right Volume Control Register

| Bits | Bit Name | Description | | | | | | | | | | | | |
|--------|-------------|--|------------------|--------|--------|------------------|-----|-----|--------|------|-----|-----|--------|------|
| [7:2] | RHPVOL[5:0] | Headphone volume control for right channel, RHP output. Each 1-bit step corresponds to a 1 dB increase in volume. See Table 95 for a complete list of the volume settings. | | | | | | | | | | | | |
| | | <table border="1"> <thead> <tr> <th>Setting</th> <th>Volume</th> </tr> </thead> <tbody> <tr> <td>000000</td> <td>-57 dB (default)</td> </tr> <tr> <td>...</td> <td>...</td> </tr> <tr> <td>111001</td> <td>0 dB</td> </tr> <tr> <td>...</td> <td>...</td> </tr> <tr> <td>111111</td> <td>6 dB</td> </tr> </tbody> </table> | Setting | Volume | 000000 | -57 dB (default) | ... | ... | 111001 | 0 dB | ... | ... | 111111 | 6 dB |
| | | Setting | Volume | | | | | | | | | | | |
| | | 000000 | -57 dB (default) | | | | | | | | | | | |
| | | ... | ... | | | | | | | | | | | |
| 111001 | 0 dB | | | | | | | | | | | | | |
| ... | ... | | | | | | | | | | | | | |
| 111111 | 6 dB | | | | | | | | | | | | | |
| 1 | RHPM | Headphone mute for right channel, RHP output (active low). 0 = mute. 1 = unmute (default). | | | | | | | | | | | | |
| 0 | HPMODE | RHP and LHP output mode. These pins can be configured for either line outputs or headphone outputs. Logical OR with the HPEN bit in Register R29. If either the HPMODE bit or the HPEN bit is set to 1, the headphone output is enabled. 0 = enable line output (default). 1 = enable headphone output. | | | | | | | | | | | | |

R31: Playback Line Output Left Volume Control, 16,421 (0x4025)

| | | | | | | | |
|--------------|-------|-------|-------|-------|-------|-------|--------|
| Bit 7 | Bit 6 | Bit 5 | Bit 4 | Bit 3 | Bit 2 | Bit 1 | Bit 0 |
| LOUTVOL[5:0] | | | | | | LOUTM | LOMODE |

Table 65. Playback Line Output Left Volume Control Register

| Bits | Bit Name | Description | | | | | | | | | | | | |
|--------|--------------|--|------------------|--------|--------|------------------|-----|-----|--------|------|-----|-----|--------|------|
| [7:2] | LOUTVOL[5:0] | Line output volume control for left channel, LOUTN and LOUTP outputs. Each 1-bit step corresponds to a 1 dB increase in volume. See Table 95 for a complete list of the volume settings. | | | | | | | | | | | | |
| | | <table border="1"> <thead> <tr> <th>Setting</th> <th>Volume</th> </tr> </thead> <tbody> <tr> <td>000000</td> <td>-57 dB (default)</td> </tr> <tr> <td>...</td> <td>...</td> </tr> <tr> <td>111001</td> <td>0 dB</td> </tr> <tr> <td>...</td> <td>...</td> </tr> <tr> <td>111111</td> <td>6 dB</td> </tr> </tbody> </table> | Setting | Volume | 000000 | -57 dB (default) | ... | ... | 111001 | 0 dB | ... | ... | 111111 | 6 dB |
| | | Setting | Volume | | | | | | | | | | | |
| | | 000000 | -57 dB (default) | | | | | | | | | | | |
| | | ... | ... | | | | | | | | | | | |
| 111001 | 0 dB | | | | | | | | | | | | | |
| ... | ... | | | | | | | | | | | | | |
| 111111 | 6 dB | | | | | | | | | | | | | |
| 1 | LOUTM | Line output mute for left channel, LOUTN and LOUTP outputs (active low). 0 = mute. 1 = unmute (default). | | | | | | | | | | | | |
| 0 | LOMODE | Line output mode for left channel, LOUTN and LOUTP outputs. These pins can be configured for either line outputs or headphone outputs. To drive earpiece speakers, set this bit to 1 (headphone output). 0 = line output (default). 1 = headphone output. | | | | | | | | | | | | |

R32: Playback Line Output Right Volume Control, 16,422 (0x4026)

| Bit 7 | Bit 6 | Bit 5 | Bit 4 | Bit 3 | Bit 2 | Bit 1 | Bit 0 |
|--------------|-------|-------|-------|-------|-------|-------|--------|
| ROUTVOL[5:0] | | | | | | ROUTM | ROMODE |

Table 66. Playback Line Output Right Volume Control Register

| Bits | Bit Name | Description | | | | | | | | | | | | |
|---------|------------------|---|---------|--------|--------|------------------|-----|-----|--------|------|-----|-----|--------|------|
| [7:2] | ROUTVOL[5:0] | Line output volume control for right channel, ROUTN and ROUTH outputs. Each 1-bit step corresponds to a 1 dB increase in volume. See Table 95 for a complete list of the volume settings. <table border="1"> <thead> <tr> <th>Setting</th> <th>Volume</th> </tr> </thead> <tbody> <tr> <td>000000</td> <td>-57 dB (default)</td> </tr> <tr> <td>...</td> <td>...</td> </tr> <tr> <td>111001</td> <td>0 dB</td> </tr> <tr> <td>...</td> <td>...</td> </tr> <tr> <td>111111</td> <td>6 dB</td> </tr> </tbody> </table> | Setting | Volume | 000000 | -57 dB (default) | ... | ... | 111001 | 0 dB | ... | ... | 111111 | 6 dB |
| Setting | Volume | | | | | | | | | | | | | |
| 000000 | -57 dB (default) | | | | | | | | | | | | | |
| ... | ... | | | | | | | | | | | | | |
| 111001 | 0 dB | | | | | | | | | | | | | |
| ... | ... | | | | | | | | | | | | | |
| 111111 | 6 dB | | | | | | | | | | | | | |
| 1 | ROUTM | Line output mute for right channel, ROUTN and ROUTH outputs (active low). 0 = mute. 1 = unmute (default). | | | | | | | | | | | | |
| 0 | ROMODE | Line output mode for right channel, ROUTN and ROUTH outputs. These pins can be configured for either line outputs or headphone outputs. To drive earpiece speakers, set this bit to 1 (headphone output). 0 = line output (default). 1 = headphone output. | | | | | | | | | | | | |

R33: Playback Mono Output Control, 16,423 (0x4027)

| Bit 7 | Bit 6 | Bit 5 | Bit 4 | Bit 3 | Bit 2 | Bit 1 | Bit 0 |
|--------------|-------|-------|-------|-------|-------|-------|--------|
| MONOVOL[5:0] | | | | | | MONOM | MOMODE |

Table 67. Playback Mono Output Control Register

| Bits | Bit Name | Description | | | | | | | | | | | | |
|---------|------------------|---|---------|--------|--------|------------------|-----|-----|--------|------|-----|-----|--------|------|
| [7:2] | MONOVOL[5:0] | Mono output volume control. Each 1-bit step corresponds to a 1 dB increase in volume. If MX7[1:0] in Register R28 is set for common-mode output, volume control is disabled. See Table 95 for a complete list of the volume settings. <table border="1"> <thead> <tr> <th>Setting</th> <th>Volume</th> </tr> </thead> <tbody> <tr> <td>000000</td> <td>-57 dB (default)</td> </tr> <tr> <td>...</td> <td>...</td> </tr> <tr> <td>111001</td> <td>0 dB</td> </tr> <tr> <td>...</td> <td>...</td> </tr> <tr> <td>111111</td> <td>6 dB</td> </tr> </tbody> </table> | Setting | Volume | 000000 | -57 dB (default) | ... | ... | 111001 | 0 dB | ... | ... | 111111 | 6 dB |
| Setting | Volume | | | | | | | | | | | | | |
| 000000 | -57 dB (default) | | | | | | | | | | | | | |
| ... | ... | | | | | | | | | | | | | |
| 111001 | 0 dB | | | | | | | | | | | | | |
| ... | ... | | | | | | | | | | | | | |
| 111111 | 6 dB | | | | | | | | | | | | | |
| 1 | MONOM | Mono output mute (active low). 0 = mute. 1 = unmute (default). | | | | | | | | | | | | |
| 0 | MOMODE | Headphone mode enable. If MX7[1:0] in Register R28 is set for common-mode output for a capless headphone configuration, this bit should be set to 1 (headphone output). 0 = line output (default). 1 = headphone output. | | | | | | | | | | | | |

R34: Playback Pop/Click Suppression, 16,424 (0x4028)

| | | | | | | | |
|--------------|--------------|--------------|--------------|--------------|--------------|--------------|--------------|
| Bit 7 | Bit 6 | Bit 5 | Bit 4 | Bit 3 | Bit 2 | Bit 1 | Bit 0 |
| Reserved | | | POPMODE | POPLESS | ASLEW[1:0] | | Reserved |

Table 68. Playback Pop/Click Suppression Register

| Bits | Bit Name | Description | | | | | | | | | | |
|---------|--------------------|---|---------|-----------|----|--------------------|----|---------|----|-------|----|-----|
| 4 | POPMODE | Pop suppression circuit power saving mode. The pop suppression circuits charge faster in normal operation; however, after they are charged, they can be put into low power operation. 0 = normal (default). 1 = low power. | | | | | | | | | | |
| 3 | POPLESS | Pop suppression disable. The pop suppression circuits are enabled by default. They can be disabled to save power; however, disabling the circuits increases the risk of pops and clicks. 0 = enabled (default). 1 = disabled. | | | | | | | | | | |
| [2:1] | ASLEW[1:0] | Analog volume slew rate for playback volume controls. | | | | | | | | | | |
| | | <table border="1"> <thead> <tr> <th>Setting</th> <th>Slew Rate</th> </tr> </thead> <tbody> <tr> <td>00</td> <td>21.25 ms (default)</td> </tr> <tr> <td>01</td> <td>42.5 ms</td> </tr> <tr> <td>10</td> <td>85 ms</td> </tr> <tr> <td>11</td> <td>Off</td> </tr> </tbody> </table> | Setting | Slew Rate | 00 | 21.25 ms (default) | 01 | 42.5 ms | 10 | 85 ms | 11 | Off |
| Setting | Slew Rate | | | | | | | | | | | |
| 00 | 21.25 ms (default) | | | | | | | | | | | |
| 01 | 42.5 ms | | | | | | | | | | | |
| 10 | 85 ms | | | | | | | | | | | |
| 11 | Off | | | | | | | | | | | |

R35: Playback Power Management, 16,425 (0x4029)

| | | | | | | | |
|--------------|--------------|--------------|--------------|--------------|--------------|--------------|--------------|
| Bit 7 | Bit 6 | Bit 5 | Bit 4 | Bit 3 | Bit 2 | Bit 1 | Bit 0 |
| HPBIAS[1:0] | | DACBIAS[1:0] | | PBIAS[1:0] | | PREN | PLEN |

Table 69. Playback Power Management Register

| Bits | Bit Name | Description | | | | | | | | | | |
|---------|----------------------------|---|---------|----------------------------|----|----------------------------|----|----------------------|----|----------------------|----|--------------|
| [7:6] | HPBIAS[1:0] | Headphone bias control. | | | | | | | | | | |
| | | <table border="1"> <thead> <tr> <th>Setting</th> <th>Headphone Bias Control</th> </tr> </thead> <tbody> <tr> <td>00</td> <td>Normal operation (default)</td> </tr> <tr> <td>01</td> <td>Extreme power saving</td> </tr> <tr> <td>10</td> <td>Enhanced performance</td> </tr> <tr> <td>11</td> <td>Power saving</td> </tr> </tbody> </table> | Setting | Headphone Bias Control | 00 | Normal operation (default) | 01 | Extreme power saving | 10 | Enhanced performance | 11 | Power saving |
| Setting | Headphone Bias Control | | | | | | | | | | | |
| 00 | Normal operation (default) | | | | | | | | | | | |
| 01 | Extreme power saving | | | | | | | | | | | |
| 10 | Enhanced performance | | | | | | | | | | | |
| 11 | Power saving | | | | | | | | | | | |
| [5:4] | DACBIAS[1:0] | DAC bias control. | | | | | | | | | | |
| | | <table border="1"> <thead> <tr> <th>Setting</th> <th>DAC Bias Control</th> </tr> </thead> <tbody> <tr> <td>00</td> <td>Normal operation (default)</td> </tr> <tr> <td>01</td> <td>Extreme power saving</td> </tr> <tr> <td>10</td> <td>Enhanced performance</td> </tr> <tr> <td>11</td> <td>Power saving</td> </tr> </tbody> </table> | Setting | DAC Bias Control | 00 | Normal operation (default) | 01 | Extreme power saving | 10 | Enhanced performance | 11 | Power saving |
| Setting | DAC Bias Control | | | | | | | | | | | |
| 00 | Normal operation (default) | | | | | | | | | | | |
| 01 | Extreme power saving | | | | | | | | | | | |
| 10 | Enhanced performance | | | | | | | | | | | |
| 11 | Power saving | | | | | | | | | | | |
| [3:2] | PBIAS[1:0] | Playback path channel bias control. | | | | | | | | | | |
| | | <table border="1"> <thead> <tr> <th>Setting</th> <th>Playback Path Bias Control</th> </tr> </thead> <tbody> <tr> <td>00</td> <td>Normal operation (default)</td> </tr> <tr> <td>01</td> <td>Reserved</td> </tr> <tr> <td>10</td> <td>Enhanced performance</td> </tr> <tr> <td>11</td> <td>Power saving</td> </tr> </tbody> </table> | Setting | Playback Path Bias Control | 00 | Normal operation (default) | 01 | Reserved | 10 | Enhanced performance | 11 | Power saving |
| Setting | Playback Path Bias Control | | | | | | | | | | | |
| 00 | Normal operation (default) | | | | | | | | | | | |
| 01 | Reserved | | | | | | | | | | | |
| 10 | Enhanced performance | | | | | | | | | | | |
| 11 | Power saving | | | | | | | | | | | |
| 1 | PREN | Playback right channel enable. 0 = disabled (default). 1 = enabled. | | | | | | | | | | |
| 0 | PLEN | Playback left channel enable. 0 = disabled (default). 1 = enabled. | | | | | | | | | | |

R36: DAC Control 0, 16,426 (0x402A)

| | | | | | | | |
|--------------|--------------|--------------|--------------|--------------|--------------|--------------|--------------|
| Bit 7 | Bit 6 | Bit 5 | Bit 4 | Bit 3 | Bit 2 | Bit 1 | Bit 0 |
| DACMONO[1:0] | | DACPOL | Reserved | | DEMPH | DACEN[1:0] | |

Table 70. DAC Control 0 Register

| Bits | Bit Name | Description | |
|-------|--------------|---|----------------------------|
| [7:6] | DACMONO[1:0] | DAC mono mode. The DAC channels can be set to mono mode within the DAC and output on the left channel, the right channel, or both channels. | |
| | | Setting | Mono Mode |
| | | 00 | Stereo (default) |
| | | 01 | Left channel in mono mode |
| | | 10 | Right channel in mono mode |
| | 11 | Both channels in mono mode | |
| 5 | DACPOL | Invert input polarity of the DACs. 0 = normal (default). 1 = inverted. | |
| 2 | DEMPH | DAC de-emphasis filter enable. The de-emphasis filter is designed for use with a sampling rate of 44.1 kHz only. 0 = disabled (default). 1 = enabled. | |
| [1:0] | DACEN[1:0] | DAC enable. | |
| | | Setting | DACs Enabled |
| | | 00 | Both off (default) |
| | | 01 | Left on |
| | | 10 | Right on |
| | 11 | Both on | |

R37: DAC Control 1, 16,427 (0x402B)

| | | | | | | | |
|--------------|--------------|--------------|--------------|--------------|--------------|--------------|--------------|
| Bit 7 | Bit 6 | Bit 5 | Bit 4 | Bit 3 | Bit 2 | Bit 1 | Bit 0 |
| LDAVOL[7:0] | | | | | | | |

Table 71. DAC Control 1 Register

| Bits | Bit Name | Description | |
|----------|-------------|--|---------------------------|
| [7:0] | LDAVOL[7:0] | Controls the digital volume attenuation for left channel inputs from the left DAC. Each bit corresponds to a 0.375 dB step with slewing between settings. See Table 94 for a complete list of the volume settings. | |
| | | Setting | Volume Attenuation |
| | | 00000000 | 0 dB (default) |
| | | 00000001 | -0.375 dB |
| | | 00000010 | -0.75 dB |
| | | ... | ... |
| | | 11111110 | -95.25 dB |
| 11111111 | -95.625 dB | | |

R38: DAC Control 2, 16,428 (0x402C)

| | | | | | | | |
|-------------|-------|-------|-------|-------|-------|-------|-------|
| Bit 7 | Bit 6 | Bit 5 | Bit 4 | Bit 3 | Bit 2 | Bit 1 | Bit 0 |
| RDAVOL[7:0] | | | | | | | |

Table 72. DAC Control 2 Register

| Bits | Bit Name | Description | | | | | | | | | | | | | | |
|----------|--------------------|---|---------|--------------------|----------|----------------|----------|-----------|----------|----------|-----|-----|----------|-----------|----------|------------|
| [7:0] | RDAVOL[7:0] | Controls the digital volume attenuation for right channel inputs from the right DAC. Each bit corresponds to a 0.375 dB step with slewing between settings. See Table 94 for a complete list of the volume settings. | | | | | | | | | | | | | | |
| | | <table border="1"> <thead> <tr> <th>Setting</th> <th>Volume Attenuation</th> </tr> </thead> <tbody> <tr> <td>00000000</td> <td>0 dB (default)</td> </tr> <tr> <td>00000001</td> <td>-0.375 dB</td> </tr> <tr> <td>00000010</td> <td>-0.75 dB</td> </tr> <tr> <td>...</td> <td>...</td> </tr> <tr> <td>11111110</td> <td>-95.25 dB</td> </tr> <tr> <td>11111111</td> <td>-95.625 dB</td> </tr> </tbody> </table> | Setting | Volume Attenuation | 00000000 | 0 dB (default) | 00000001 | -0.375 dB | 00000010 | -0.75 dB | ... | ... | 11111110 | -95.25 dB | 11111111 | -95.625 dB |
| Setting | Volume Attenuation | | | | | | | | | | | | | | | |
| 00000000 | 0 dB (default) | | | | | | | | | | | | | | | |
| 00000001 | -0.375 dB | | | | | | | | | | | | | | | |
| 00000010 | -0.75 dB | | | | | | | | | | | | | | | |
| ... | ... | | | | | | | | | | | | | | | |
| 11111110 | -95.25 dB | | | | | | | | | | | | | | | |
| 11111111 | -95.625 dB | | | | | | | | | | | | | | | |

R39: Serial Port Pad Control, 16,429 (0x402D)

The optional pull-up/pull-down resistors are nominally 250 kΩ. When enabled, these pull-up/pull-down resistors set the serial port signals to a defined state when the signal source becomes three-state.

| | | | | | | | |
|-------------|-------|-------------|-------|-------------|-------|------------|-------|
| Bit 7 | Bit 6 | Bit 5 | Bit 4 | Bit 3 | Bit 2 | Bit 1 | Bit 0 |
| ADCSDP[1:0] | | DACSDP[1:0] | | LRCLKP[1:0] | | BCLKP[1:0] | |

Table 73. Serial Port Pad Control Register

| Bits | Bit Name | Description | | | | | | | | | | |
|---------|----------------|--|---------|---------------|----|---------|----|----------|----|----------------|----|-----------|
| [7:6] | ADCSDP[1:0] | ADC_SDATA pad pull-up/pull-down configuration. | | | | | | | | | | |
| | | <table border="1"> <thead> <tr> <th>Setting</th> <th>Configuration</th> </tr> </thead> <tbody> <tr> <td>00</td> <td>Pull-up</td> </tr> <tr> <td>01</td> <td>Reserved</td> </tr> <tr> <td>10</td> <td>None (default)</td> </tr> <tr> <td>11</td> <td>Pull-down</td> </tr> </tbody> </table> | Setting | Configuration | 00 | Pull-up | 01 | Reserved | 10 | None (default) | 11 | Pull-down |
| Setting | Configuration | | | | | | | | | | | |
| 00 | Pull-up | | | | | | | | | | | |
| 01 | Reserved | | | | | | | | | | | |
| 10 | None (default) | | | | | | | | | | | |
| 11 | Pull-down | | | | | | | | | | | |
| [5:4] | DACSDP[1:0] | DAC_SDATA pad pull-up/pull-down configuration. | | | | | | | | | | |
| | | <table border="1"> <thead> <tr> <th>Setting</th> <th>Configuration</th> </tr> </thead> <tbody> <tr> <td>00</td> <td>Pull-up</td> </tr> <tr> <td>01</td> <td>Reserved</td> </tr> <tr> <td>10</td> <td>None (default)</td> </tr> <tr> <td>11</td> <td>Pull-down</td> </tr> </tbody> </table> | Setting | Configuration | 00 | Pull-up | 01 | Reserved | 10 | None (default) | 11 | Pull-down |
| Setting | Configuration | | | | | | | | | | | |
| 00 | Pull-up | | | | | | | | | | | |
| 01 | Reserved | | | | | | | | | | | |
| 10 | None (default) | | | | | | | | | | | |
| 11 | Pull-down | | | | | | | | | | | |
| [3:2] | LRCLKP[1:0] | LRCLK pad pull-up/pull-down configuration. | | | | | | | | | | |
| | | <table border="1"> <thead> <tr> <th>Setting</th> <th>Configuration</th> </tr> </thead> <tbody> <tr> <td>00</td> <td>Pull-up</td> </tr> <tr> <td>01</td> <td>Reserved</td> </tr> <tr> <td>10</td> <td>None (default)</td> </tr> <tr> <td>11</td> <td>Pull-down</td> </tr> </tbody> </table> | Setting | Configuration | 00 | Pull-up | 01 | Reserved | 10 | None (default) | 11 | Pull-down |
| Setting | Configuration | | | | | | | | | | | |
| 00 | Pull-up | | | | | | | | | | | |
| 01 | Reserved | | | | | | | | | | | |
| 10 | None (default) | | | | | | | | | | | |
| 11 | Pull-down | | | | | | | | | | | |
| [1:0] | BCLKP[1:0] | BCLK pad pull-up/pull-down configuration. | | | | | | | | | | |
| | | <table border="1"> <thead> <tr> <th>Setting</th> <th>Configuration</th> </tr> </thead> <tbody> <tr> <td>00</td> <td>Pull-up</td> </tr> <tr> <td>01</td> <td>Reserved</td> </tr> <tr> <td>10</td> <td>None (default)</td> </tr> <tr> <td>11</td> <td>Pull-down</td> </tr> </tbody> </table> | Setting | Configuration | 00 | Pull-up | 01 | Reserved | 10 | None (default) | 11 | Pull-down |
| Setting | Configuration | | | | | | | | | | | |
| 00 | Pull-up | | | | | | | | | | | |
| 01 | Reserved | | | | | | | | | | | |
| 10 | None (default) | | | | | | | | | | | |
| 11 | Pull-down | | | | | | | | | | | |

R40: Control Port Pad Control 0, 16,431 (0x402F)

The optional pull-up/pull-down resistors are nominally 250 kΩ. When enabled, these pull-up/pull-down resistors set the control port signals to a defined state when the signal source becomes three-state.

| Bit 7 | Bit 6 | Bit 5 | Bit 4 | Bit 3 | Bit 2 | Bit 1 | Bit 0 |
|------------|-------|------------|-------|-----------|-------|-----------|-------|
| CDATP[1:0] | | CLCHP[1:0] | | SCLP[1:0] | | SDAP[1:0] | |

Table 74. Control Port Pad Control 0 Register

| Bits | Bit Name | Description | |
|-------|------------|---|----------------------|
| [7:6] | CDATP[1:0] | CDATA pad pull-up/pull-down configuration. | |
| | | Setting | Configuration |
| | | 00 | Pull-up |
| | | 01 | Reserved |
| | | 10 | None (default) |
| [5:4] | CLCHP[1:0] | CLATCH pad pull-up/pull-down configuration. | |
| | | Setting | Configuration |
| | | 00 | Pull-up |
| | | 01 | Reserved |
| | | 10 | None (default) |
| [3:2] | SCLP[1:0] | SCL/CCLK pad pull-up/pull-down configuration. | |
| | | Setting | Configuration |
| | | 00 | Pull-up |
| | | 01 | Reserved |
| | | 10 | None (default) |
| [1:0] | SDAP[1:0] | SDA/COUT pad pull-up/pull-down configuration. | |
| | | Setting | Configuration |
| | | 00 | Pull-up |
| | | 01 | Reserved |
| | | 10 | None (default) |
| | | 11 | Pull-down |

R41: Control Port Pad Control 1, 16,432 (0x4030)

With IOVDD set to 3.3 V, the low and high drive strengths of the SDA/COUT pin are approximately 2.0 mA and 4.0 mA, respectively. With IOVDD set to 1.8 V, the low and high drive strengths are approximately 0.8 mA and 1.7 mA, respectively. The high drive strength mode may be useful for generating a stronger ACK pulse in I²C mode, if needed.

| Bit 7 | Bit 6 | Bit 5 | Bit 4 | Bit 3 | Bit 2 | Bit 1 | Bit 0 |
|----------|-------|-------|-------|-------|-------|-------|--------|
| Reserved | | | | | | | SDASTR |

Table 75. Control Port Pad Control 1 Register

| Bits | Bit Name | Description |
|------|----------|---|
| 0 | SDASTR | SDA/COUT pin drive strength. 0 = low (default). 1 = high. |

R42: Jack Detect Pin Control, 16,433 (0x4031)

With IOVDD set to 3.3 V, the low and high drive strengths of the JACKDET/MICIN pin are approximately 2.0 mA and 4.0 mA, respectively. With IOVDD set to 1.8 V, the low and high drive strengths are approximately 0.8 mA and 1.7 mA, respectively. The optional pull-up/pull-down resistors are nominally 250 kΩ. When enabled, these pull-up/pull-down resistors set the input signals to a defined state when the signal source becomes three-state.

| | | | | | | | |
|--------------|--------------|--------------|--------------|--------------|--------------|--------------|--------------|
| Bit 7 | Bit 6 | Bit 5 | Bit 4 | Bit 3 | Bit 2 | Bit 1 | Bit 0 |
| Reserved | | JDSTR | Reserved | JDP[1:0] | | Reserved | |

Table 76. Jack Detect Pin Control Register

| Bits | Bit Name | Description | | | | | | | | | | |
|---------|----------------|--|---------|---------------|----|---------|----|----------|----|----------------|----|-----------|
| 5 | JDSTR | JACKDET/MICIN pin drive strength. 0 = low (default). 1 = high. | | | | | | | | | | |
| [3:2] | JDP[1:0] | JACKDET/MICIN pad pull-up/pull-down configuration. | | | | | | | | | | |
| | | <table border="1"> <thead> <tr> <th>Setting</th> <th>Configuration</th> </tr> </thead> <tbody> <tr> <td>00</td> <td>Pull-up</td> </tr> <tr> <td>01</td> <td>Reserved</td> </tr> <tr> <td>10</td> <td>None (default)</td> </tr> <tr> <td>11</td> <td>Pull-down</td> </tr> </tbody> </table> | Setting | Configuration | 00 | Pull-up | 01 | Reserved | 10 | None (default) | 11 | Pull-down |
| Setting | Configuration | | | | | | | | | | | |
| 00 | Pull-up | | | | | | | | | | | |
| 01 | Reserved | | | | | | | | | | | |
| 10 | None (default) | | | | | | | | | | | |
| 11 | Pull-down | | | | | | | | | | | |

R67: Dejitter Control, 16,438 (0x4036)

The dejitter control register allows the size of the dejitter window to be set, and also allows all dejitter circuits in the device to be activated or bypassed. Dejitter circuits protect against duplicate samples or skipped samples due to jitter from the serial ports in slave mode. Disabling and reenabling certain subsystems in the device—that is, the ADCs, serial ports, SigmaDSP core, and DACs—during operation can cause the associated dejitter circuits to fail. As a result, audio data fails to be output to the next subsystem in the device.

When the serial ports are in master mode, the dejitter circuit can be bypassed by setting the dejitter window to 0. When the serial ports are in slave mode, the dejitter circuit can be reinitialized prior to outputting audio from the device, guaranteeing that audio is output to the next subsystem in the device. Any time that audio must pass through the ADCs, serial port, sound engine/DSP core, or DACs, the dejitter circuit can be bypassed and reset by setting the dejitter window size to 0. In this way, the dejitter circuit can be immediately reactivated, without a wait period, by setting the dejitter window size to the default value of 3.

| | | | | | | | |
|--------------|--------------|--------------|--------------|--------------|--------------|--------------|--------------|
| Bit 7 | Bit 6 | Bit 5 | Bit 4 | Bit 3 | Bit 2 | Bit 1 | Bit 0 |
| DEJIT[7:0] | | | | | | | |

Table 77. Dejitter Control Register

| Bits | Bit Name | Description | | | | | | | | | | | | |
|-------------|-------------------|--|-------------|-------------------|----------|---|-----|-----|----------|-------------|-----|-----|----------|---|
| [7:0] | DEJIT[7:0] | Dejitter window size. | | | | | | | | | | | | |
| | | <table border="1"> <thead> <tr> <th>Window Size</th> <th>Core Clock Cycles</th> </tr> </thead> <tbody> <tr> <td>00000000</td> <td>0</td> </tr> <tr> <td>...</td> <td>...</td> </tr> <tr> <td>00000011</td> <td>3 (default)</td> </tr> <tr> <td>...</td> <td>...</td> </tr> <tr> <td>00000101</td> <td>5</td> </tr> </tbody> </table> | Window Size | Core Clock Cycles | 00000000 | 0 | ... | ... | 00000011 | 3 (default) | ... | ... | 00000101 | 5 |
| Window Size | Core Clock Cycles | | | | | | | | | | | | | |
| 00000000 | 0 | | | | | | | | | | | | | |
| ... | ... | | | | | | | | | | | | | |
| 00000011 | 3 (default) | | | | | | | | | | | | | |
| ... | ... | | | | | | | | | | | | | |
| 00000101 | 5 | | | | | | | | | | | | | |

R43 to R47: Cyclic Redundancy Check Registers, 16,576 to 16,580 (0x40C0 to 0x40C4)

The cyclic redundancy check (CRC) constantly checks the validity of the program RAM contents. SigmaStudio generates a 32-bit hash sum, which must be written to four consecutive read-only 8-bit register locations. CRC must then be enabled. Every 1024 frames (21 ms at 48 kHz), the IC generates its own 32-bit code and compares it to the one stored in these registers. If the codes do not match, a GPIO pin is set high (CRC flag). This output flag must be enabled using the output CRC error sticky setting in the GPIO pin control register (see Table 79). The 1-bit CRC error flag is reset when the CRCEN bit goes low. For example, a GPIO pin can be connected to an interrupt pin on an external microcontroller, which triggers a rewrite of the corrupted memory.

By default, CRC is disabled (the CRCEN bit is set to 0). To enable continuous CRC checking, the user can set the CRCEN bit to 1 after loading a program and sending the correct CRC, which is calculated by SigmaStudio. If an error occurs, it can be cleared by setting the CRCEN bit low, fixing the error (presumably by reloading the program), and then setting the CRCEN bit high again.

| Address | Bit 7 | Bit 6 | Bit 5 | Bit 4 | Bit 3 | Bit 2 | Bit 1 | Bit 0 |
|---------|------------|-------|-------|-------|-------|-------|-------|-------|
| 0x40C0 | CRC[31:24] | | | | | | | |
| 0x40C1 | CRC[23:16] | | | | | | | |
| 0x40C2 | CRC[15:8] | | | | | | | |
| 0x40C3 | CRC[7:0] | | | | | | | |
| 0x40C4 | Reserved | | | | | | | CRCEN |

Table 78. Cyclic Redundancy Check Registers

| Register | Address | | Bit Name | Description |
|----------|---------|--------|------------|---|
| | Decimal | Hex | | |
| R43 | 16,576 | 0x40C0 | CRC[31:24] | CRC hash sum, Bits[31:24] (read-only register) |
| R44 | 16,577 | 0x40C1 | CRC[23:16] | CRC hash sum, Bits[23:16] (read-only register) |
| R45 | 16,578 | 0x40C2 | CRC[15:8] | CRC hash sum, Bits[15:8] (read-only register) |
| R46 | 16,579 | 0x40C3 | CRC[7:0] | CRC hash sum, Bits[7:0] (read-only register) |
| R47 | 16,580 | 0x40C4 | CRCEN | CRC enable 0 = disabled (default) 1 = enabled |

R48 to R51: GPIO Pin Control, 16,582 to 16,585 (0x40C6 to 0x40C9)

The GPIO pin control register sets the functionality of each GPIO pin as shown in Table 79. The GPIO functions use the same pins as the serial port and must be enabled in the serial data/GPIO pin configuration register (Address 0x40F4). When the GPIO pins are set to I²C/SPI port control mode, the pins are set through writes to memory locations described in Table 32. The value of the optional internal pull-up is nominally 250 kΩ.

The output CRC error and output watchdog error settings are sticky, that is, once set, they remain set until the ADAU1761 is reset.

| Address | Bit 7 | Bit 6 | Bit 5 | Bit 4 | Bit 3 | Bit 2 | Bit 1 | Bit 0 |
|---------|----------|-------|-------|-------|------------|-------|-------|-------|
| 0x40C6 | Reserved | | | | GPIO0[3:0] | | | |
| 0x40C7 | Reserved | | | | GPIO1[3:0] | | | |
| 0x40C8 | Reserved | | | | GPIO2[3:0] | | | |
| 0x40C9 | Reserved | | | | GPIO3[3:0] | | | |

Table 79. GPIO Pin Functionality Bit Settings

| GPIOx[3:0] Bits | GPIO Pin Function |
|-----------------|---|
| 0000 | Input without debounce (default) |
| 0001 | Input with debounce (0.3 ms) |
| 0010 | Input with debounce (0.6 ms) |
| 0011 | Input with debounce (0.9 ms) |
| 0100 | Input with debounce (5 ms) |
| 0101 | Input with debounce (10 ms) |
| 0110 | Input with debounce (20 ms) |
| 0111 | Input with debounce (40 ms) |
| 1000 | Input controlled by I ² C/SPI port |
| 1001 | Output set by I ² C/SPI port, with pull-up |
| 1010 | Output set by I ² C/SPI port, no pull-up |
| 1011 | Output set by DSP core, with pull-up |
| 1100 | Output set by DSP core, no pull-up |
| 1101 | Reserved |
| 1110 | Output CRC error (sticky) |
| 1111 | Output watchdog error (sticky) |

Table 80. GPIO Pin Control Registers

| Register | Address | | Bit Name | Description |
|----------|---------|--------|------------|------------------------------------|
| | Decimal | Hex | | |
| R48 | 16,582 | 0x40C6 | GPIO0[3:0] | GPIO 0 pin function (see Table 79) |
| R49 | 16,583 | 0x40C7 | GPIO1[3:0] | GPIO 1 pin function (see Table 79) |
| R50 | 16,584 | 0x40C8 | GPIO2[3:0] | GPIO 2 pin function (see Table 79) |
| R51 | 16,585 | 0x40C9 | GPIO3[3:0] | GPIO 3 pin function (see Table 79) |

R52 to R56: Watchdog Registers, 16,592 to 16,596 (0x40D0 to 0x40D4)

A program counter watchdog is used when the core does block processing (which can span several samples). The watchdog flags an error if the program counter reaches a specific 24-bit value (ranging from 0x000000 to 0xFFFFFFFF) that is set in the register map. This value consists of three consecutive 8-bit register locations. The error flag sends a high signal to one of the GPIO pins. The watchdog function must be enabled by setting the DOGEN bit high in Register R52 (Address 0x40D0).

The watchdog error bit (DOGER) is the 1-bit watchdog error flag that can be sent to a GPIO pin, as described in Table 79. This error flag can connect, for example, to an interrupt pin on a microcontroller in the system. The flag is reset when the DOGEN bit goes low. This flag can also be read back over the control port from Register R56 (Address 0x40D4).

| Address | Bit 7 | Bit 6 | Bit 5 | Bit 4 | Bit 3 | Bit 2 | Bit 1 | Bit 0 |
|---------|------------|-------|-------|-------|-------|-------|-------|-------|
| 0x40D0 | Reserved | | | | | | | DOGEN |
| 0x40D1 | DOG[23:16] | | | | | | | |
| 0x40D2 | DOG[15:8] | | | | | | | |
| 0x40D3 | DOG[7:0] | | | | | | | |
| 0x40D4 | Reserved | | | | | | | DOGER |

Table 81. Watchdog Registers

| Register | Address | | Bit Name | Description | | | |
|----------|---------|--------|------------|--|------------------|-----------------|--------------------|
| | Decimal | Hex | | | | | |
| R52 | 16,592 | 0x40D0 | DOGEN | Watchdog enable bit. 0 = disabled (default). 1 = enabled. | | | |
| R53 | 16,593 | 0x40D1 | DOG[23:16] | Watchdog value, Bits[23:16] (MSB). | | | |
| R54 | 16,594 | 0x40D2 | DOG[15:8] | Watchdog value, Bits[15:8]. | | | |
| R55 | 16,595 | 0x40D3 | DOG[7:0] | Watchdog value, Bits[7:0]. | | | |
| | | | | DOG[23:16] | DOG[15:8] | DOG[7:0] | Hex Value |
| | | | | 00000000 | 00000000 | 00000000 | 0x000000 (default) |
| | | | | ... | ... | ... | ... |
| | | | | 11111111 | 11111111 | 11111111 | 0xFFFFFFFF |
| R56 | 16,596 | 0x40D4 | DOGER | Watchdog error (read-only bit). 0 = no error (default). 1 = error. | | | |

R57: DSP Sampling Rate Setting, 16,619 (0x40EB)

| Bit 7 | Bit 6 | Bit 5 | Bit 4 | Bit 3 | Bit 2 | Bit 1 | Bit 0 |
|----------|-------|-------|-------|------------|-------|-------|-------|
| Reserved | | | | DSPSR[3:0] | | | |

Table 82. DSP Sampling Rate Setting Register

| Bits | Bit Name | Description | | | | | | | | | | | | | | | | | | | | | | | | | | | | | | | | | |
|---------|-------------------------|--|---------|---------------|--------------------------------------|------|-----------|--------------|------|-------|------------------|------|-----------|--------|------|---------|--------|------|---------|--------|------|---------|--------|------|---------|-------|------|------------------------|--|------|-------------------------|--|------|------|--|
| [3:0] | DSPSR[3:0] | SigmaDSP core sampling rate. The DSP sampling rate is a ratio of the base sampling rate, f_s . The base sampling rate is determined by the operating frequency of the core clock. For most applications, the SigmaDSP core sampling rate should equal the converter sampling rate (set using the CONVSR[2:0] bits in Register R17) and the serial port sampling rate (set using the SPSR[2:0] bits in Register R64). | | | | | | | | | | | | | | | | | | | | | | | | | | | | | | | | | |
| | | <table border="1"> <thead> <tr> <th>Setting</th> <th>Sampling Rate</th> <th>Base Sampling Rate ($f_s = 48$ kHz)</th> </tr> </thead> <tbody> <tr> <td>0000</td> <td>$f_s/0.5$</td> <td>96 kHz, base</td> </tr> <tr> <td>0001</td> <td>f_s</td> <td>48 kHz (default)</td> </tr> <tr> <td>0010</td> <td>$f_s/1.5$</td> <td>32 kHz</td> </tr> <tr> <td>0011</td> <td>$f_s/2$</td> <td>24 kHz</td> </tr> <tr> <td>0100</td> <td>$f_s/3$</td> <td>16 kHz</td> </tr> <tr> <td>0101</td> <td>$f_s/4$</td> <td>12 kHz</td> </tr> <tr> <td>0110</td> <td>$f_s/6$</td> <td>8 kHz</td> </tr> <tr> <td>0111</td> <td>Serial input data rate</td> <td></td> </tr> <tr> <td>1000</td> <td>Serial output data rate</td> <td></td> </tr> <tr> <td>1111</td> <td>None</td> <td></td> </tr> </tbody> </table> | Setting | Sampling Rate | Base Sampling Rate ($f_s = 48$ kHz) | 0000 | $f_s/0.5$ | 96 kHz, base | 0001 | f_s | 48 kHz (default) | 0010 | $f_s/1.5$ | 32 kHz | 0011 | $f_s/2$ | 24 kHz | 0100 | $f_s/3$ | 16 kHz | 0101 | $f_s/4$ | 12 kHz | 0110 | $f_s/6$ | 8 kHz | 0111 | Serial input data rate | | 1000 | Serial output data rate | | 1111 | None | |
| Setting | Sampling Rate | Base Sampling Rate ($f_s = 48$ kHz) | | | | | | | | | | | | | | | | | | | | | | | | | | | | | | | | | |
| 0000 | $f_s/0.5$ | 96 kHz, base | | | | | | | | | | | | | | | | | | | | | | | | | | | | | | | | | |
| 0001 | f_s | 48 kHz (default) | | | | | | | | | | | | | | | | | | | | | | | | | | | | | | | | | |
| 0010 | $f_s/1.5$ | 32 kHz | | | | | | | | | | | | | | | | | | | | | | | | | | | | | | | | | |
| 0011 | $f_s/2$ | 24 kHz | | | | | | | | | | | | | | | | | | | | | | | | | | | | | | | | | |
| 0100 | $f_s/3$ | 16 kHz | | | | | | | | | | | | | | | | | | | | | | | | | | | | | | | | | |
| 0101 | $f_s/4$ | 12 kHz | | | | | | | | | | | | | | | | | | | | | | | | | | | | | | | | | |
| 0110 | $f_s/6$ | 8 kHz | | | | | | | | | | | | | | | | | | | | | | | | | | | | | | | | | |
| 0111 | Serial input data rate | | | | | | | | | | | | | | | | | | | | | | | | | | | | | | | | | | |
| 1000 | Serial output data rate | | | | | | | | | | | | | | | | | | | | | | | | | | | | | | | | | | |
| 1111 | None | | | | | | | | | | | | | | | | | | | | | | | | | | | | | | | | | | |

R58: Serial Input Route Control, 16,626 (0x40F2)

| | | | | | | | |
|----------|-------|-------|-------|------------|-------|-------|-------|
| Bit 7 | Bit 6 | Bit 5 | Bit 4 | Bit 3 | Bit 2 | Bit 1 | Bit 0 |
| Reserved | | | | SINRT[3:0] | | | |

Table 83. Serial Input Route Control Register

| Bits | Bit Name | Description | | | | | | | | | | | | | | | | | | | | | | | | | | | | | | | | | | |
|---------|--------------------------------------|--|---------|---------|------|------------------------------|------|--------------------------------------|------|----------|------|--------------------------------------|------|----------|------|--------------------------------------|------|----------|------|--------------------------------------|------|----------|------|--------------------------------------|------|----------|------|--------------------------------------|------|----------|------|--------------------------------------|------|----------|------|--------------------------------------|
| [3:0] | SINRT[3:0] | Serial data input routing. This register sets the input where the DACs receive serial data. This location can be from the DSP or from any TDM slot on the serial port. | | | | | | | | | | | | | | | | | | | | | | | | | | | | | | | | | | |
| | | <table border="1"> <thead> <tr> <th>Setting</th> <th>Routing</th> </tr> </thead> <tbody> <tr><td>0000</td><td>DSP to DACs [L, R] (default)</td></tr> <tr><td>0001</td><td>Serial input [L0, R0] to DACs [L, R]</td></tr> <tr><td>0010</td><td>Reserved</td></tr> <tr><td>0011</td><td>Serial input [L1, R1] to DACs [L, R]</td></tr> <tr><td>0100</td><td>Reserved</td></tr> <tr><td>0101</td><td>Serial input [L2, R2] to DACs [L, R]</td></tr> <tr><td>0110</td><td>Reserved</td></tr> <tr><td>0111</td><td>Serial input [L3, R3] to DACs [L, R]</td></tr> <tr><td>1000</td><td>Reserved</td></tr> <tr><td>1001</td><td>Serial input [R0, L0] to DACs [L, R]</td></tr> <tr><td>1010</td><td>Reserved</td></tr> <tr><td>1011</td><td>Serial input [R1, L1] to DACs [L, R]</td></tr> <tr><td>1100</td><td>Reserved</td></tr> <tr><td>1101</td><td>Serial input [R2, L2] to DACs [L, R]</td></tr> <tr><td>1110</td><td>Reserved</td></tr> <tr><td>1111</td><td>Serial input [R3, L3] to DACs [L, R]</td></tr> </tbody> </table> | Setting | Routing | 0000 | DSP to DACs [L, R] (default) | 0001 | Serial input [L0, R0] to DACs [L, R] | 0010 | Reserved | 0011 | Serial input [L1, R1] to DACs [L, R] | 0100 | Reserved | 0101 | Serial input [L2, R2] to DACs [L, R] | 0110 | Reserved | 0111 | Serial input [L3, R3] to DACs [L, R] | 1000 | Reserved | 1001 | Serial input [R0, L0] to DACs [L, R] | 1010 | Reserved | 1011 | Serial input [R1, L1] to DACs [L, R] | 1100 | Reserved | 1101 | Serial input [R2, L2] to DACs [L, R] | 1110 | Reserved | 1111 | Serial input [R3, L3] to DACs [L, R] |
| Setting | Routing | | | | | | | | | | | | | | | | | | | | | | | | | | | | | | | | | | | |
| 0000 | DSP to DACs [L, R] (default) | | | | | | | | | | | | | | | | | | | | | | | | | | | | | | | | | | | |
| 0001 | Serial input [L0, R0] to DACs [L, R] | | | | | | | | | | | | | | | | | | | | | | | | | | | | | | | | | | | |
| 0010 | Reserved | | | | | | | | | | | | | | | | | | | | | | | | | | | | | | | | | | | |
| 0011 | Serial input [L1, R1] to DACs [L, R] | | | | | | | | | | | | | | | | | | | | | | | | | | | | | | | | | | | |
| 0100 | Reserved | | | | | | | | | | | | | | | | | | | | | | | | | | | | | | | | | | | |
| 0101 | Serial input [L2, R2] to DACs [L, R] | | | | | | | | | | | | | | | | | | | | | | | | | | | | | | | | | | | |
| 0110 | Reserved | | | | | | | | | | | | | | | | | | | | | | | | | | | | | | | | | | | |
| 0111 | Serial input [L3, R3] to DACs [L, R] | | | | | | | | | | | | | | | | | | | | | | | | | | | | | | | | | | | |
| 1000 | Reserved | | | | | | | | | | | | | | | | | | | | | | | | | | | | | | | | | | | |
| 1001 | Serial input [R0, L0] to DACs [L, R] | | | | | | | | | | | | | | | | | | | | | | | | | | | | | | | | | | | |
| 1010 | Reserved | | | | | | | | | | | | | | | | | | | | | | | | | | | | | | | | | | | |
| 1011 | Serial input [R1, L1] to DACs [L, R] | | | | | | | | | | | | | | | | | | | | | | | | | | | | | | | | | | | |
| 1100 | Reserved | | | | | | | | | | | | | | | | | | | | | | | | | | | | | | | | | | | |
| 1101 | Serial input [R2, L2] to DACs [L, R] | | | | | | | | | | | | | | | | | | | | | | | | | | | | | | | | | | | |
| 1110 | Reserved | | | | | | | | | | | | | | | | | | | | | | | | | | | | | | | | | | | |
| 1111 | Serial input [R3, L3] to DACs [L, R] | | | | | | | | | | | | | | | | | | | | | | | | | | | | | | | | | | | |

R59: Serial Output Route Control, 16,627 (0x40F3)

| | | | | | | | |
|----------|-------|-------|-------|-------------|-------|-------|-------|
| Bit 7 | Bit 6 | Bit 5 | Bit 4 | Bit 3 | Bit 2 | Bit 1 | Bit 0 |
| Reserved | | | | SOUTRT[3:0] | | | |

Table 84. Serial Output Route Control Register

| Bits | Bit Name | Description | | | | | | | | | | | | | | | | | | | | | | | | | | | | | | | | | | |
|---------|---------------------------------------|--|---------|---------|------|------------------------------|------|---------------------------------------|------|----------|------|---------------------------------------|------|----------|------|---------------------------------------|------|----------|------|---------------------------------------|------|----------|------|---------------------------------------|------|----------|------|---------------------------------------|------|----------|------|---------------------------------------|------|----------|------|---------------------------------------|
| [3:0] | SOUTRT[3:0] | Serial data output routing. This register sets the output where the ADCs send serial data. This location can be to the DSP or to any TDM slot on the serial port. | | | | | | | | | | | | | | | | | | | | | | | | | | | | | | | | | | |
| | | <table border="1"> <thead> <tr> <th>Setting</th> <th>Routing</th> </tr> </thead> <tbody> <tr><td>0000</td><td>ADCs [L, R] to DSP (default)</td></tr> <tr><td>0001</td><td>ADCs [L, R] to serial output [L0, R0]</td></tr> <tr><td>0010</td><td>Reserved</td></tr> <tr><td>0011</td><td>ADCs [L, R] to serial output [L1, R1]</td></tr> <tr><td>0100</td><td>Reserved</td></tr> <tr><td>0101</td><td>ADCs [L, R] to serial output [L2, R2]</td></tr> <tr><td>0110</td><td>Reserved</td></tr> <tr><td>0111</td><td>ADCs [L, R] to serial output [L3, R3]</td></tr> <tr><td>1000</td><td>Reserved</td></tr> <tr><td>1001</td><td>ADCs [L, R] to serial output [R0, L0]</td></tr> <tr><td>1010</td><td>Reserved</td></tr> <tr><td>1011</td><td>ADCs [L, R] to serial output [R1, L1]</td></tr> <tr><td>1100</td><td>Reserved</td></tr> <tr><td>1101</td><td>ADCs [L, R] to serial output [R2, L2]</td></tr> <tr><td>1110</td><td>Reserved</td></tr> <tr><td>1111</td><td>ADCs [L, R] to serial output [R3, L3]</td></tr> </tbody> </table> | Setting | Routing | 0000 | ADCs [L, R] to DSP (default) | 0001 | ADCs [L, R] to serial output [L0, R0] | 0010 | Reserved | 0011 | ADCs [L, R] to serial output [L1, R1] | 0100 | Reserved | 0101 | ADCs [L, R] to serial output [L2, R2] | 0110 | Reserved | 0111 | ADCs [L, R] to serial output [L3, R3] | 1000 | Reserved | 1001 | ADCs [L, R] to serial output [R0, L0] | 1010 | Reserved | 1011 | ADCs [L, R] to serial output [R1, L1] | 1100 | Reserved | 1101 | ADCs [L, R] to serial output [R2, L2] | 1110 | Reserved | 1111 | ADCs [L, R] to serial output [R3, L3] |
| Setting | Routing | | | | | | | | | | | | | | | | | | | | | | | | | | | | | | | | | | | |
| 0000 | ADCs [L, R] to DSP (default) | | | | | | | | | | | | | | | | | | | | | | | | | | | | | | | | | | | |
| 0001 | ADCs [L, R] to serial output [L0, R0] | | | | | | | | | | | | | | | | | | | | | | | | | | | | | | | | | | | |
| 0010 | Reserved | | | | | | | | | | | | | | | | | | | | | | | | | | | | | | | | | | | |
| 0011 | ADCs [L, R] to serial output [L1, R1] | | | | | | | | | | | | | | | | | | | | | | | | | | | | | | | | | | | |
| 0100 | Reserved | | | | | | | | | | | | | | | | | | | | | | | | | | | | | | | | | | | |
| 0101 | ADCs [L, R] to serial output [L2, R2] | | | | | | | | | | | | | | | | | | | | | | | | | | | | | | | | | | | |
| 0110 | Reserved | | | | | | | | | | | | | | | | | | | | | | | | | | | | | | | | | | | |
| 0111 | ADCs [L, R] to serial output [L3, R3] | | | | | | | | | | | | | | | | | | | | | | | | | | | | | | | | | | | |
| 1000 | Reserved | | | | | | | | | | | | | | | | | | | | | | | | | | | | | | | | | | | |
| 1001 | ADCs [L, R] to serial output [R0, L0] | | | | | | | | | | | | | | | | | | | | | | | | | | | | | | | | | | | |
| 1010 | Reserved | | | | | | | | | | | | | | | | | | | | | | | | | | | | | | | | | | | |
| 1011 | ADCs [L, R] to serial output [R1, L1] | | | | | | | | | | | | | | | | | | | | | | | | | | | | | | | | | | | |
| 1100 | Reserved | | | | | | | | | | | | | | | | | | | | | | | | | | | | | | | | | | | |
| 1101 | ADCs [L, R] to serial output [R2, L2] | | | | | | | | | | | | | | | | | | | | | | | | | | | | | | | | | | | |
| 1110 | Reserved | | | | | | | | | | | | | | | | | | | | | | | | | | | | | | | | | | | |
| 1111 | ADCs [L, R] to serial output [R3, L3] | | | | | | | | | | | | | | | | | | | | | | | | | | | | | | | | | | | |

R60: Serial Data/GPIO Pin Configuration, 16,628 (0x40F4)

The serial data/GPIO pin configuration register controls the functionality of the serial data port pins. If the bits in this register are set to 1, these pins are configured as GPIO interfaces to the SigmaDSP. If these bits are set to 0, they are configured as serial data I/O port pins.

| Bit 7 | Bit 6 | Bit 5 | Bit 4 | Bit 3 | Bit 2 | Bit 1 | Bit 0 |
|----------|-------|-------|-------|-------|-------|--------|--------|
| Reserved | | | | LRGP3 | BGP2 | SDOGP1 | SDIGP0 |

Table 85. Serial Data/GPIO Pin Configuration Register

| Bits | Bit Name | Description |
|------|----------|--|
| 3 | LRGP3 | LRCLK or GPIO3 pin configuration select. 0 = LRCLK enabled (default). 1 = GPIO3 enabled. |
| 2 | BGP2 | BCLK or GPIO2 pin configuration select. 0 = BCLK enabled (default). 1 = GPIO2 enabled. |
| 1 | SDOGP1 | ADC_SDATA or GPIO1 pin configuration select. 0 = ADC_SDATA enabled (default). 1 = GPIO1 enabled. |
| 0 | SDIGP0 | DAC_SDATA or GPIO0 pin configuration select. 0 = DAC_SDATA enabled (default). 1 = GPIO0 enabled. |

R61: DSP Enable, 16,629 (0x40F5)

| Bit 7 | Bit 6 | Bit 5 | Bit 4 | Bit 3 | Bit 2 | Bit 1 | Bit 0 |
|----------|-------|-------|-------|-------|-------|-------|-------|
| Reserved | | | | | | | DSPEN |

Table 86. DSP Enable Register

| Bits | Bit Name | Description |
|------|----------|--|
| 0 | DSPEN | Enables the DSP. Set this bit before writing to the parameter RAM and before setting the DSPRUN bit in Register R62 (Address 0x40F6). 0 = DSP disabled (default). 1 = DSP enabled. |

R62: DSP Run, 16,630 (0x40F6)

| Bit 7 | Bit 6 | Bit 5 | Bit 4 | Bit 3 | Bit 2 | Bit 1 | Bit 0 |
|----------|-------|-------|-------|-------|-------|-------|--------|
| Reserved | | | | | | | DSPRUN |

Table 87. DSP Run Register

| Bits | Bit Name | Description |
|------|----------|--|
| 0 | DSPRUN | Run the DSP. Set the DSPEN bit in Register R61 (Address 0x40F5) before setting this bit. 0 = DSP off (default). 1 = run the DSP. |

R63: DSP Slew Modes, 16,631 (0x40F7)

The DSP slew modes register sets the slew source for each output. The slew source can be either the DSP (digital slew) or the codec (analog slew). When these bits are set to Logic 0, the codec provides volume slew according to the ASLEW[1:0] bits in Register R34 (playback pop/click suppression register, Address 0x4028). When these bits are set to Logic 1, the slew is provided and defined by the DSP program, disabling the codec volume slew.

| | | | | | | | |
|--------------|--------------|--------------|--------------|--------------|--------------|--------------|--------------|
| Bit 7 | Bit 6 | Bit 5 | Bit 4 | Bit 3 | Bit 2 | Bit 1 | Bit 0 |
| Reserved | | | MOSLW | ROSLW | LOSLW | RHPSLW | LHPSLW |

Table 88. DSP Slew Modes Register

| Bits | Bit Name | Description |
|------|----------|--|
| 4 | MOSLW | Mono output slew generation. 0 = codec (default). 1 = DSP. |
| 3 | ROSLW | Line output right slew generation. 0 = codec (default). 1 = DSP. |
| 2 | LOSLW | Line output left slew generation. 0 = codec (default). 1 = DSP. |
| 1 | RHPSLW | Headphone right slew generation. 0 = codec (default). 1 = DSP. |
| 0 | LHPSLW | Headphone left slew generation. 0 = codec (default). 1 = DSP. |

R64: Serial Port Sampling Rate, 16,632 (0x40F8)

| | | | | | | | |
|--------------|--------------|--------------|--------------|--------------|--------------|--------------|--------------|
| Bit 7 | Bit 6 | Bit 5 | Bit 4 | Bit 3 | Bit 2 | Bit 1 | Bit 0 |
| Reserved | | | | | SPSR[2:0] | | |

Table 89. Serial Port Sampling Rate Register

| Bits | Bit Name | Description | | | | | | | | | | | | | | | | | | | | | | | | | | | |
|---------|---------------|---|---------|---------------|--------------------------------------|-----|-------|------------------------|-----|---------|-------|-----|---------|--------|-----|---------|--------|-----|---------|--------|-----|-----------|--------|-----|-----------|--------|-----|----------|--|
| [2:0] | SPSR[2:0] | Serial port sampling rate. The serial port sampling rate is a ratio of the base sampling rate, f_s . The base sampling rate is determined by the operating frequency of the core clock. For most applications, the serial port sampling rate should equal the converter sampling rate (set using the CONVSR[2:0] bits in Register R17) and the DSP sampling rate (set using the DSPSR[3:0] bits in Register R57). | | | | | | | | | | | | | | | | | | | | | | | | | | | |
| | | <table border="1"> <thead> <tr> <th>Setting</th> <th>Sampling Rate</th> <th>Base Sampling Rate ($f_s = 48$ kHz)</th> </tr> </thead> <tbody> <tr> <td>000</td> <td>f_s</td> <td>48 kHz, base (default)</td> </tr> <tr> <td>001</td> <td>$f_s/6$</td> <td>8 kHz</td> </tr> <tr> <td>010</td> <td>$f_s/4$</td> <td>12 kHz</td> </tr> <tr> <td>011</td> <td>$f_s/3$</td> <td>16 kHz</td> </tr> <tr> <td>100</td> <td>$f_s/2$</td> <td>24 kHz</td> </tr> <tr> <td>101</td> <td>$f_s/1.5$</td> <td>32 kHz</td> </tr> <tr> <td>110</td> <td>$f_s/0.5$</td> <td>96 kHz</td> </tr> <tr> <td>111</td> <td>Reserved</td> <td></td> </tr> </tbody> </table> | Setting | Sampling Rate | Base Sampling Rate ($f_s = 48$ kHz) | 000 | f_s | 48 kHz, base (default) | 001 | $f_s/6$ | 8 kHz | 010 | $f_s/4$ | 12 kHz | 011 | $f_s/3$ | 16 kHz | 100 | $f_s/2$ | 24 kHz | 101 | $f_s/1.5$ | 32 kHz | 110 | $f_s/0.5$ | 96 kHz | 111 | Reserved | |
| Setting | Sampling Rate | Base Sampling Rate ($f_s = 48$ kHz) | | | | | | | | | | | | | | | | | | | | | | | | | | | |
| 000 | f_s | 48 kHz, base (default) | | | | | | | | | | | | | | | | | | | | | | | | | | | |
| 001 | $f_s/6$ | 8 kHz | | | | | | | | | | | | | | | | | | | | | | | | | | | |
| 010 | $f_s/4$ | 12 kHz | | | | | | | | | | | | | | | | | | | | | | | | | | | |
| 011 | $f_s/3$ | 16 kHz | | | | | | | | | | | | | | | | | | | | | | | | | | | |
| 100 | $f_s/2$ | 24 kHz | | | | | | | | | | | | | | | | | | | | | | | | | | | |
| 101 | $f_s/1.5$ | 32 kHz | | | | | | | | | | | | | | | | | | | | | | | | | | | |
| 110 | $f_s/0.5$ | 96 kHz | | | | | | | | | | | | | | | | | | | | | | | | | | | |
| 111 | Reserved | | | | | | | | | | | | | | | | | | | | | | | | | | | | |

R65: Clock Enable 0, 16,633 (0x40F9)

This register disables or enables the digital clock engine for different blocks within the ADAU1761. For maximum power saving, use this register to disable blocks that are not being used.

| Bit 7 | Bit 6 | Bit 5 | Bit 4 | Bit 3 | Bit 2 | Bit 1 | Bit 0 |
|----------|--------|-------|-------|--------|-------|-------|-------|
| Reserved | SLEWPD | ALCPD | DECPD | SOUTPD | INTPD | SINPD | SPPD |

Table 90. Clock Enable 0 Register

| Bits | Bit Name | Description |
|------|----------|--|
| 6 | SLEWPD | Codec slew digital clock engine enable. When powered down, the analog playback path volume controls are disabled and stay set to their current state. 0 = powered down (default). 1 = enabled. |
| 5 | ALCPD | ALC digital clock engine enable. 0 = powered down (default). 1 = enabled. |
| 4 | DECPD | Decimator resync (dejitter) digital clock engine enable. 0 = powered down (default). 1 = enabled. |
| 3 | SOUTPD | Serial routing outputs digital clock engine enable. 0 = powered down (default). 1 = enabled. |
| 2 | INTPD | Interpolator resync (dejitter) digital clock engine enable. 0 = powered down (default). 1 = enabled. |
| 1 | SINPD | Serial routing inputs digital clock engine enable. 0 = powered down (default). 1 = enabled. |
| 0 | SPPD | Serial port digital clock engine enable. 0 = powered down (default). 1 = enabled. |

R66: Clock Enable 1, 16,634 (0x40FA)

This register enables Digital Clock Generator 0 and Digital Clock Generator 1. Digital Clock Generator 0 generates sample rates for the ADCs, DACs, and DSP. Digital Clock Generator 1 generates BCLK and LRCLK for the serial port when the part is in master mode. For maximum power saving, use this register to disable clocks that are not being used.

| Bit 7 | Bit 6 | Bit 5 | Bit 4 | Bit 3 | Bit 2 | Bit 1 | Bit 0 |
|----------|-------|-------|-------|-------|-------|-------|-------|
| Reserved | | | | | | CLK1 | CLK0 |

Table 91. Clock Enable 1 Register

| Bits | Bit Name | Description |
|------|----------|---|
| 1 | CLK1 | Digital Clock Generator 1. 0 = off (default). 1 = on. |
| 0 | CLK0 | Digital Clock Generator 0. 0 = off (default). 1 = on. |

Table 92. R8 and R9 Volume Settings

| Binary Value | Volume Setting (dB) |
|--------------|---------------------|
| 000000 | -12 |
| 000001 | -11.25 |
| 000010 | -10.5 |
| 000011 | -9.75 |
| 000100 | -9 |
| 000101 | -8.25 |
| 000110 | -7.5 |
| 000111 | -6.75 |
| 001000 | -6 |
| 001001 | -5.25 |
| 001010 | -4.5 |
| 001011 | -3.75 |
| 001100 | -3 |
| 001101 | -2.25 |
| 001110 | -1.5 |
| 001111 | -0.75 |
| 010000 | 0 |
| 010001 | 0.75 |
| 010010 | 1.5 |
| 010011 | 2.25 |
| 010100 | 3 |
| 010101 | 3.75 |
| 010110 | 4.5 |
| 010111 | 5.25 |
| 011000 | 6 |
| 011001 | 6.75 |
| 011010 | 7.5 |
| 011011 | 8.25 |
| 011100 | 9 |
| 011101 | 9.75 |
| 011110 | 10.5 |
| 011111 | 11.25 |
| 100000 | 12 |
| 100001 | 12.75 |
| 100010 | 13.5 |
| 100011 | 14.25 |
| 100100 | 15 |
| 100101 | 15.75 |
| 100110 | 16.5 |
| 100111 | 17.25 |
| 101000 | 18 |
| 101001 | 18.75 |
| 101010 | 19.5 |
| 101011 | 20.25 |
| 101100 | 21 |
| 101101 | 21.75 |
| 101110 | 22.5 |
| 101111 | 23.25 |
| 110000 | 24 |
| 110001 | 24.75 |
| 110010 | 25.5 |

| Binary Value | Volume Setting (dB) |
|--------------|---------------------|
| 110011 | 26.25 |
| 110100 | 27 |
| 110101 | 27.75 |
| 110110 | 28.5 |
| 110111 | 29.25 |
| 111000 | 30 |
| 111001 | 30.75 |
| 111010 | 31.5 |
| 111011 | 32.25 |
| 111100 | 33 |
| 111101 | 33.75 |
| 111110 | 34.5 |
| 111111 | 35.25 |

Table 93. R14 Noise Gate Threshold

| Binary Value | Noise Gate Threshold (dB) |
|--------------|---------------------------|
| 000000 | -76.5 |
| 000001 | -75 |
| 000010 | -73.5 |
| 000011 | -72 |
| 000100 | -70.5 |
| 000101 | -69 |
| 000110 | -67.5 |
| 000111 | -66 |
| 001000 | -64.5 |
| 001001 | -63 |
| 001010 | -61.5 |
| 001011 | -60 |
| 001100 | -58.5 |
| 001101 | -57 |
| 001110 | -55.5 |
| 001111 | -54 |
| 010000 | -52.5 |
| 010001 | -51 |
| 010010 | -49.5 |
| 010011 | -48 |
| 010100 | -46.5 |
| 010101 | -45 |
| 010110 | -43.5 |
| 010111 | -42 |
| 011000 | -40.5 |
| 011001 | -39 |
| 011010 | -37.5 |
| 011011 | -36 |
| 011100 | -34.5 |
| 011101 | -33 |
| 011110 | -31.5 |
| 011111 | -30 |

Table 94. R20, R21, R37, and R38 Volume Settings

| Binary Value | Volume Attenuation (dB) | Binary Value | Volume Attenuation (dB) |
|--------------|-------------------------|--------------|-------------------------|
| 00000000 | 0 | 00110000 | -18 |
| 00000001 | -0.375 | 00110001 | -18.375 |
| 00000010 | -0.75 | 00110010 | -18.75 |
| 00000011 | -1.125 | 00110011 | -19.125 |
| 00000100 | -1.5 | 00110100 | -19.5 |
| 00000101 | -1.875 | 00110101 | -19.875 |
| 00000110 | -2.25 | 00110110 | -20.25 |
| 00000111 | -2.625 | 00110111 | -20.625 |
| 00001000 | -3 | 00111000 | -21 |
| 00001001 | -3.375 | 00111001 | -21.375 |
| 00001010 | -3.75 | 00111010 | -21.75 |
| 00001011 | -4.125 | 00111011 | -22.125 |
| 00001100 | -4.5 | 00111100 | -22.5 |
| 00001101 | -4.875 | 00111101 | -22.875 |
| 00001110 | -5.25 | 00111110 | -23.25 |
| 00001111 | -5.625 | 00111111 | -23.625 |
| 00010000 | -6 | 01000000 | -24 |
| 00010001 | -6.375 | 01000001 | -24.375 |
| 00010010 | -6.75 | 01000010 | -24.75 |
| 00010011 | -7.125 | 01000011 | -25.125 |
| 00010100 | -7.5 | 01000100 | -25.5 |
| 00010101 | -7.875 | 01000101 | -25.875 |
| 00010110 | -8.25 | 01000110 | -26.25 |
| 00010111 | -8.625 | 01000111 | -26.625 |
| 00011000 | -9 | 01001000 | -27 |
| 00011001 | -9.375 | 01001001 | -27.375 |
| 00011010 | -9.75 | 01001010 | -27.75 |
| 00011011 | -10.125 | 01001011 | -28.125 |
| 00011100 | -10.5 | 01001100 | -28.5 |
| 00011101 | -10.875 | 01001101 | -28.875 |
| 00011110 | -11.25 | 01001110 | -29.25 |
| 00011111 | -11.625 | 01001111 | -29.625 |
| 00100000 | -12 | 01010000 | -30 |
| 00100001 | -12.375 | 01010001 | -30.375 |
| 00100010 | -12.75 | 01010010 | -30.75 |
| 00100011 | -13.125 | 01010011 | -31.125 |
| 00100100 | -13.5 | 01010100 | -31.5 |
| 00100101 | -13.875 | 01010101 | -31.875 |
| 00100110 | -14.25 | 01010110 | -32.25 |
| 00100111 | -14.625 | 01010111 | -32.625 |
| 00101000 | -15 | 01011000 | -33 |
| 00101001 | -15.375 | 01011001 | -33.375 |
| 00101010 | -15.75 | 01011010 | -33.75 |
| 00101011 | -16.125 | 01011011 | -34.125 |
| 00101100 | -16.5 | 01011100 | -34.5 |
| 00101101 | -16.875 | 01011101 | -34.875 |
| 00101110 | -17.25 | 01011110 | -35.25 |
| 00101111 | -17.625 | 01011111 | -35.625 |

| Binary Value | Volume Attenuation (dB) |
|---------------------|--------------------------------|
| 01100000 | -36 |
| 01100001 | -36.375 |
| 01100010 | -36.75 |
| 01100011 | -37.125 |
| 01100100 | -37.5 |
| 01100101 | -37.875 |
| 01100110 | -38.25 |
| 01100111 | -38.625 |
| 01101000 | -39 |
| 01101001 | -39.375 |
| 01101010 | -39.75 |
| 01101011 | -40.125 |
| 01101100 | -40.5 |
| 01101101 | -40.875 |
| 01101110 | -41.25 |
| 01101111 | -41.625 |
| 01110000 | -42 |
| 01110001 | -42.375 |
| 01110010 | -42.75 |
| 01110011 | -43.125 |
| 01110100 | -43.5 |
| 01110101 | -43.875 |
| 01110110 | -44.25 |
| 01110111 | -44.625 |
| 01111000 | -45 |
| 01111001 | -45.375 |
| 01111010 | -45.75 |
| 01111011 | -46.125 |
| 01111100 | -46.5 |
| 01111101 | -46.875 |
| 01111110 | -47.25 |
| 01111111 | -47.625 |
| 10000000 | -48 |
| 10000001 | -48.375 |
| 10000010 | -48.75 |
| 10000011 | -49.125 |
| 10000100 | -49.5 |
| 10000101 | -49.875 |
| 10000110 | -50.25 |
| 10000111 | -50.625 |
| 10001000 | -51 |
| 10001001 | -51.375 |
| 10001010 | -51.75 |
| 10001011 | -52.125 |
| 10001100 | -52.5 |
| 10001101 | -52.875 |
| 10001110 | -53.25 |
| 10001111 | -53.625 |
| 10010000 | -54 |

| Binary Value | Volume Attenuation (dB) |
|---------------------|--------------------------------|
| 10010001 | -54.375 |
| 10010010 | -54.75 |
| 10010011 | -55.125 |
| 10010100 | -55.5 |
| 10010101 | -55.875 |
| 10010110 | -56.25 |
| 10010111 | -56.625 |
| 10011000 | -57 |
| 10011001 | -57.375 |
| 10011010 | -57.75 |
| 10011011 | -58.125 |
| 10011100 | -58.5 |
| 10011101 | -58.875 |
| 10011110 | -59.25 |
| 10011111 | -59.625 |
| 10100000 | -60 |
| 10100001 | -60.375 |
| 10100010 | -60.75 |
| 10100011 | -61.125 |
| 10100100 | -61.5 |
| 10100101 | -61.875 |
| 10100110 | -62.25 |
| 10100111 | -62.625 |
| 10101000 | -63 |
| 10101001 | -63.375 |
| 10101010 | -63.75 |
| 10101011 | -64.125 |
| 10101100 | -64.5 |
| 10101101 | -64.875 |
| 10101110 | -65.25 |
| 10101111 | -65.625 |
| 10110000 | -66 |
| 10110001 | -66.375 |
| 10110010 | -66.75 |
| 10110011 | -67.125 |
| 10110100 | -67.5 |
| 10110101 | -67.875 |
| 10110110 | -68.25 |
| 10110111 | -68.625 |
| 10111000 | -69 |
| 10111001 | -69.375 |
| 10111010 | -69.75 |
| 10111011 | -70.125 |
| 10111100 | -70.5 |
| 10111101 | -70.875 |
| 10111110 | -71.25 |
| 10111111 | -71.625 |
| 11000000 | -72 |
| 11000001 | -72.375 |

| Binary Value | Volume Attenuation (dB) |
|--------------|-------------------------|
| 11000010 | -72.75 |
| 11000011 | -73.125 |
| 11000100 | -73.5 |
| 11000101 | -73.875 |
| 11000110 | -74.25 |
| 11000111 | -74.625 |
| 11001000 | -75 |
| 11001001 | -75.375 |
| 11001010 | -75.75 |
| 11001011 | -76.125 |
| 11001100 | -76.5 |
| 11001101 | -76.875 |
| 11001110 | -77.25 |
| 11001111 | -77.625 |
| 11010000 | -78 |
| 11010001 | -78.375 |
| 11010010 | -78.75 |
| 11010011 | -79.125 |
| 11010100 | -79.5 |
| 11010101 | -79.875 |
| 11010110 | -80.25 |
| 11010111 | -80.625 |
| 11011000 | -81 |
| 11011001 | -81.375 |
| 11011010 | -81.75 |
| 11011011 | -82.125 |
| 11011100 | -82.5 |
| 11011101 | -82.875 |
| 11011110 | -83.25 |
| 11011111 | -83.625 |
| 11100000 | -84 |
| 11100001 | -84.375 |
| 11100010 | -84.75 |
| 11100011 | -85.125 |
| 11100100 | -85.5 |
| 11100101 | -85.875 |
| 11100110 | -86.25 |
| 11100111 | -86.625 |
| 11101000 | -87 |
| 11101001 | -87.375 |
| 11101010 | -87.75 |
| 11101011 | -88.125 |
| 11101100 | -88.5 |
| 11101101 | -88.875 |
| 11101110 | -89.25 |
| 11101111 | -89.625 |
| 11110000 | -90 |
| 11110001 | -90.375 |
| 11110010 | -90.75 |

| Binary Value | Volume Attenuation (dB) |
|--------------|-------------------------|
| 11110011 | -91.125 |
| 11110100 | -91.5 |
| 11110101 | -91.875 |
| 11110110 | -92.25 |
| 11110111 | -92.625 |
| 11111000 | -93 |
| 11111001 | -93.375 |
| 11111010 | -93.75 |
| 11111011 | -94.125 |
| 11111100 | -94.5 |
| 11111101 | -94.875 |
| 11111110 | -95.25 |
| 11111111 | -95.625 |

Table 95. R29 through R33 Volume Settings

| Binary Value | Volume Setting (dB) |
|--------------|---------------------|
| 000000 | -57 |
| 000001 | -56 |
| 000010 | -55 |
| 000011 | -54 |
| 000100 | -53 |
| 000101 | -52 |
| 000110 | -51 |
| 000111 | -50 |
| 001000 | -49 |
| 001001 | -48 |
| 001010 | -47 |
| 001011 | -46 |
| 001100 | -45 |
| 001101 | -44 |
| 001110 | -43 |
| 001111 | -42 |
| 010000 | -41 |
| 010001 | -40 |
| 010010 | -39 |
| 010011 | -38 |
| 010100 | -37 |
| 010101 | -36 |
| 010110 | -35 |
| 010111 | -34 |
| 011000 | -33 |
| 011001 | -32 |
| 011010 | -31 |
| 011011 | -30 |
| 011100 | -29 |
| 011101 | -28 |
| 011110 | -27 |
| 011111 | -26 |
| 100000 | -25 |

| Binary Value | Volume Setting (dB) |
|---------------------|----------------------------|
| 100001 | -24 |
| 100010 | -23 |
| 100011 | -22 |
| 100100 | -21 |
| 100101 | -20 |
| 100110 | -19 |
| 100111 | -18 |
| 101000 | -17 |
| 101001 | -16 |
| 101010 | -15 |
| 101011 | -14 |
| 101100 | -13 |
| 101101 | -12 |
| 101110 | -11 |
| 101111 | -10 |
| 110000 | -9 |
| 110001 | -8 |
| 110010 | -7 |
| 110011 | -6 |
| 110100 | -5 |
| 110101 | -4 |
| 110110 | -3 |
| 110111 | -2 |
| 111000 | -1 |
| 111001 | 0 |
| 111010 | 1 |
| 111011 | 2 |
| 111100 | 3 |
| 111101 | 4 |
| 111110 | 5 |
| 111111 | 6 |

OUTLINE DIMENSIONS

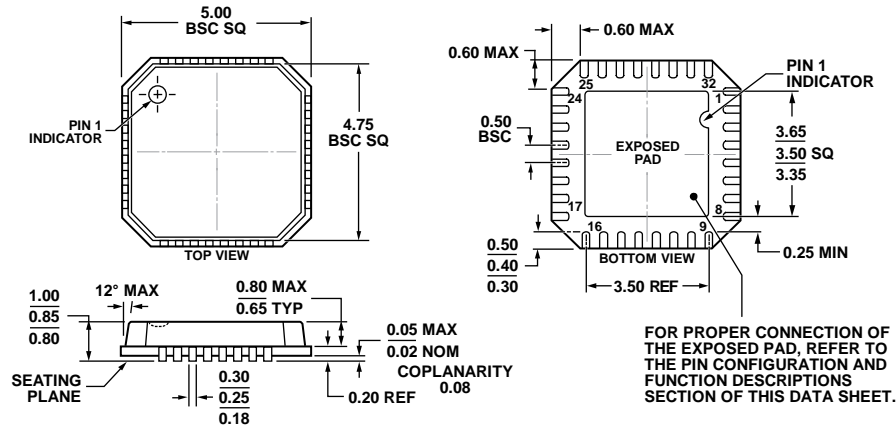

COMPLIANT TO JEDEC STANDARDS MO-220-VHHD-2

Figure 71. 32-Lead Lead Frame Chip Scale Package [LFCSP_VQ]
 5 mm × 5 mm Body, Very Thin Quad
 (CP-32-4)
 Dimensions shown in millimeters

ORDERING GUIDE

| Model ¹ | Temperature Range | Package Description | Package Option |
|--------------------|-------------------|---|----------------|
| ADAU1761BCPZ | -40°C to +85°C | 32-Lead Lead Frame Chip Scale Package [LFCSP_VQ] | CP-32-4 |
| ADAU1761BCPZ-R7 | -40°C to +85°C | 32-Lead Lead Frame Chip Scale Package [LFCSP_VQ], 7" Tape and Reel | CP-32-4 |
| ADAU1761BCPZ-RL | -40°C to +85°C | 32-Lead Lead Frame Chip Scale Package [LFCSP_VQ], 13" Tape and Reel | CP-32-4 |
| EVAL-ADAU1761Z | | Evaluation Board | |

¹ Z = RoHS Compliant Part.

勝特力材料 886-3-5753170
 勝特力电子(上海) 86-21-34970699
 勝特力电子(深圳) 86-755-83298787
[Http://www.100y.com.tw](http://www.100y.com.tw)