

# FAN3278

## 30V PMOS-NMOS Bridge Driver

### Features

- 8V to 27V Optimum Operating Range
- Drives High-Side PMOS and Low-Side NMOS in Motor Control or Buck Step-Down Applications
- Output Drive-Voltage Magnitude Limited: < 13V for  $V_{DD}$  up to 30V
- Biases Each Load Device OFF with a 100k $\Omega$  Resistor when  $V_{DD}$  Below Operating Level
- Low-Voltage TTL Input Thresholds
- Peak Gate Drives at 12V: +1.5A Sink, -1.0A Source
- Internal Resistors Hold Driver Off When No Inputs Present
- 8-Lead SOIC Package
- Rated from -40°C to +125°C Ambient

### Applications

- Motor Control with PMOS / NMOS Half-Bridge Configuration
- Buck Converters with High-Side PMOS Device; 100% Duty Cycle Operation Possible
- Logic-Controlled Load Circuits with High-Side PMOS Switch

### Description

The FAN3278 dual 1.5A gate driver is optimized to drive a high-side P-channel MOSFET and a low-side N-channel MOSFET in motor control applications operating from a voltage rail up to 27V. Internal circuitry limits the voltage applied to the gates of the external MOSFETs to 13V maximum. The driver has TTL input thresholds and provides buffer and level translation from logic inputs. Internal circuitry prevents the output switching devices from operating if the  $V_{DD}$  supply voltage is below the IC operation level. Internal 100k $\Omega$  resistors bias the non-inverting output LOW and the inverting output to  $V_{DD}$  to keep the external MOSFETs off during startup intervals when logic control signals may not be present.

The FAN3278 driver incorporates MOSFET devices for the final output stage, providing high current throughout the MOSFET turn-on / turn-off transition to minimize switching loss. The internal gate-drive regulators provide optimum gate-drive voltage when operating from a rail of 8V to 27V. The FAN3278 can be driven from a voltage rail of less than 8V; however, its gate drive current is reduced.

The FAN3278 has two independent ENABLE pins that default to ON if not connected. If the ENABLE pin for non-inverting channel A is pulled LOW, OUTA is forced LOW. If the ENABLE pin for inverting channel B is pulled LOW, OUTB is forced HIGH. If an input is left unconnected, internal resistors bias the inputs such that the external MOSFETs are OFF.

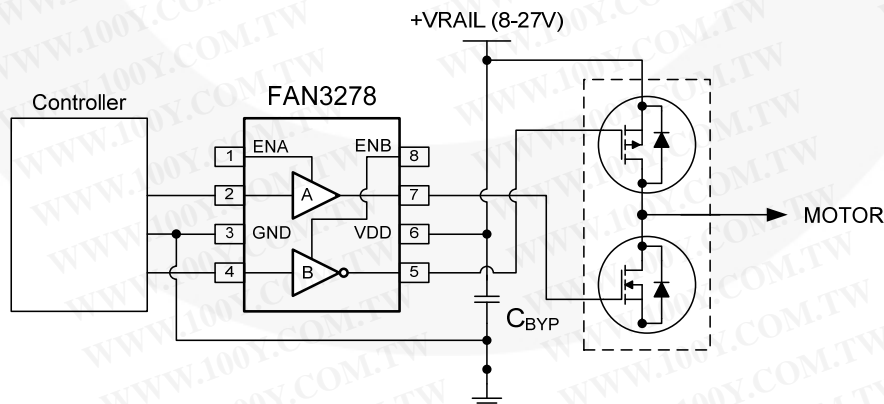

Figure 1. Typical Application

Ordering Information

Part Number	Logic	Input Threshold	Packing Method
FAN3278TMX	Non-Inverting Channel and Inverting Channel with Dual Enable	TTL	2,500 Units on Tape & Reel

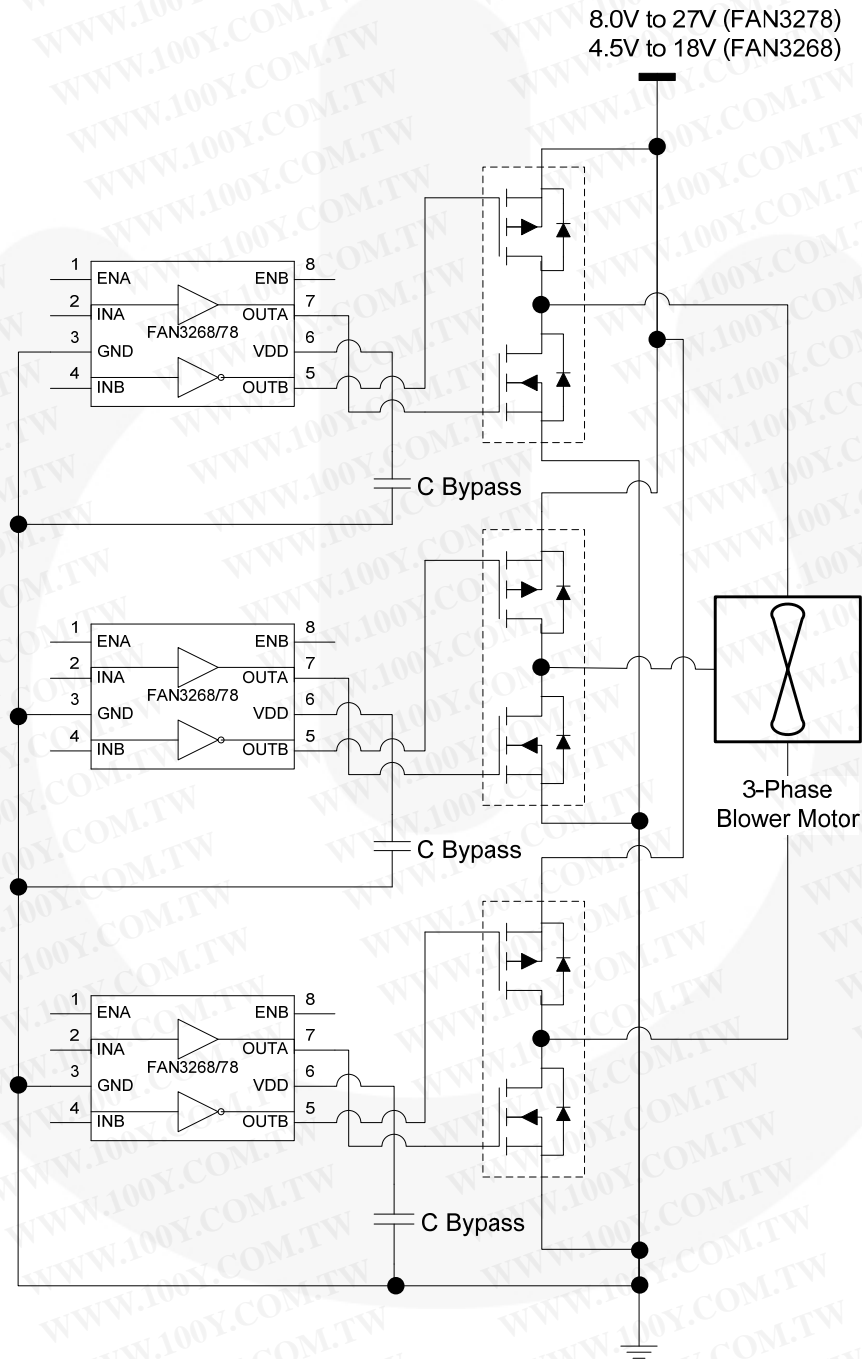

Figure 2. Typical 3-Phase Blower Motor Drive Application

## Pin Configuration

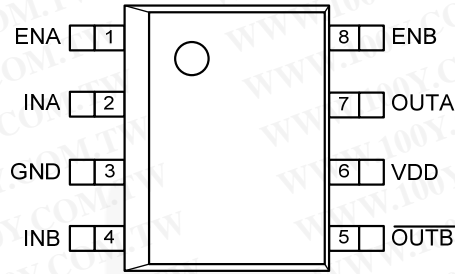

Figure 3. Pin Configuration (Top View)

## Thermal Characteristics<sup>(1)</sup>

Package	$\Theta_{JL}$ <sup>(2)</sup>	$\Theta_{JT}$ <sup>(3)</sup>	$\Theta_{JA}$ <sup>(4)</sup>	$\Psi_{JB}$ <sup>(5)</sup>	$\Psi_{JT}$ <sup>(6)</sup>	Unit
8-Pin Small-Outline Integrated Circuit (SOIC)	40	31	89	43	3	°C/W

### Notes:

- Estimates derived from thermal simulation; actual values depend on the application.
- Theta\_JL ( $\Theta_{JL}$ ): Thermal resistance between the semiconductor junction and the bottom surface of all the leads (including any thermal pad) that are typically soldered to a PCB.
- Theta\_JT ( $\Theta_{JT}$ ): Thermal resistance between the semiconductor junction and the top surface of the package, assuming it is held at a uniform temperature by a top-side heatsink.
- Theta\_JA ( $\Theta_{JA}$ ): Thermal resistance between junction and ambient, dependent on the PCB design, heat sinking, and airflow. The value given is for natural convection with no heatsink, as specified in JEDEC standards JESD51-2, JESD51-5, and JESD51-7, as appropriate.
- Psi\_JB ( $\Psi_{JB}$ ): Thermal characterization parameter providing correlation between semiconductor junction temperature and an application circuit board reference point for the thermal environment defined in Note 4. For the SOIC-8 package, the board reference is defined as the PCB copper adjacent to pin 6.
- Psi\_JT ( $\Psi_{JT}$ ): Thermal characterization parameter providing correlation between the semiconductor junction temperature and the center of the top of the package for the thermal environment defined in Note 4.

## Pin Definitions

Pin#	Name	Description
1	ENA	<b>Enable Input for Channel A.</b> Pull pin LOW to inhibit driver A. ENA has TTL thresholds.
8	ENB	<b>Enable Input for Channel B.</b> Pull pin LOW to inhibit driver B. ENB has TTL thresholds.
3	GND	<b>Ground.</b> Common ground reference for input and output circuits.
2	INA	<b>Input to Channel A.</b>
4	INB	<b>Input to Channel B.</b>
7	OUTA	<b>Gate Drive Output A:</b> Held LOW unless required input is present and $V_{DD}$ is above the internal voltage threshold where the IC is functional.
5	OUTB	<b>Gate Drive Output B</b> (inverted from the input). Held HIGH unless the required input is present and $V_{DD}$ is above the internal voltage threshold where the IC is functional.
6	VDD	<b>Supply Voltage.</b> Provides power to the IC.

### Output Logic

FAN3278 (Channel A)		
ENA	INA	OUTA
0	0 <sup>(7)</sup>	0
0	1	0
1 <sup>(7)</sup>	0 <sup>(7)</sup>	0
1 <sup>(7)</sup>	1	1

FAN3278 (Channel B)		
ENB	INB	OUTB
0	0 <sup>(7)</sup>	1
0	1	1
1 <sup>(7)</sup>	0 <sup>(7)</sup>	1
1 <sup>(7)</sup>	1	0

**Note:**

7. Default input signal if no external connection is made.

### Block Diagram

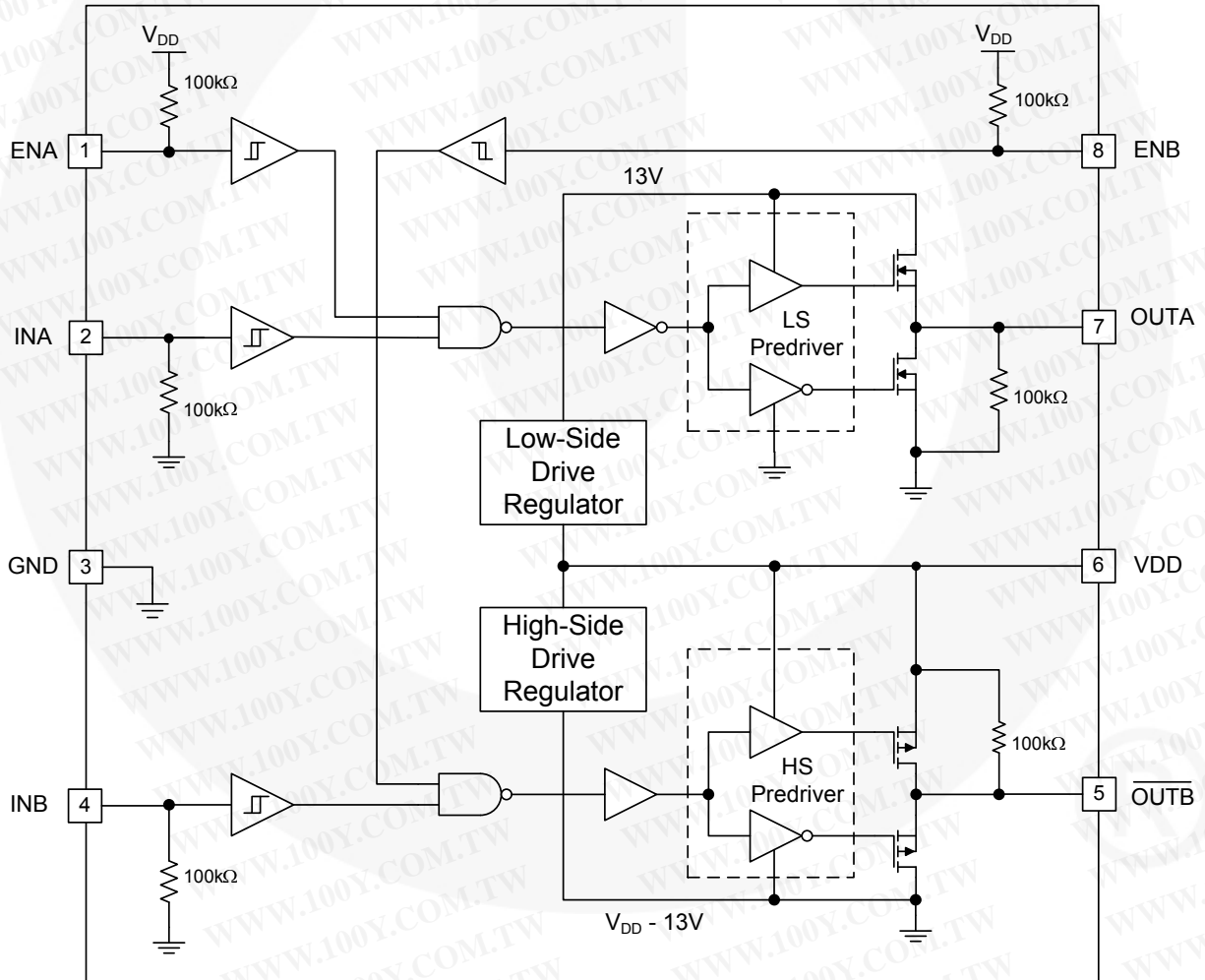

Figure 4. Block Diagram

## Absolute Maximum Ratings

Stresses exceeding the absolute maximum ratings may damage the device. The device may not function or be operable above the recommended operating conditions and stressing the parts to these levels is not recommended. In addition, extended exposure to stresses above the recommended operating conditions may affect device reliability. The absolute maximum ratings are stress ratings only.

Symbol	Parameter	Min.	Max.	Unit
V <sub>DD</sub>	VDD to PGND	-0.3	30.0	V
V <sub>EN</sub>	ENA, ENB to GND	GND - 0.3	V <sub>DD</sub> + 0.3	V
V <sub>IN</sub>	INA, INB to GND	GND - 0.3	V <sub>DD</sub> + 0.3	V
V <sub>OUT</sub>	OUTA, OUTB to GND	GND - 0.3	V <sub>DD</sub> + 0.3	V
T <sub>L</sub>	Lead Soldering Temperature (10 Seconds)		+260	°C
T <sub>J</sub>	Junction Temperature	-55	+150	°C
T <sub>STG</sub>	Storage Temperature	-65	+150	°C

## Recommended Operating Conditions

The Recommended Operating Conditions table defines the conditions for actual device operation. Recommended operating conditions are specified to ensure optimal performance to the datasheet specifications. Fairchild does not recommend exceeding them or designing to Absolute Maximum Ratings.

Symbol	Parameter	Min.	Max.	Unit
V <sub>DD</sub>	Supply Voltage Range	8	27	V
V <sub>EN</sub>	Enable Voltage (ENA, ENB)	0	V <sub>DD</sub>	V
V <sub>IN</sub>	Input Voltage (INA, INB)	0	V <sub>DD</sub>	V
T <sub>A</sub>	Operating Ambient Temperature	-40	+125	°C

## Electrical Characteristics

Unless otherwise noted,  $V_{DD}=12V$  and  $T_J=-40^{\circ}C$  to  $+125^{\circ}C$ . Currents are defined as positive into the device ( $I_{sink}$ ) and negative out of the device ( $I_{source}$ ).

Symbol	Parameter	Conditions	Min.	Typ.	Max.	Unit
<b>Supply</b>						
$V_{DD}$	Optimum Operating Range <sup>(8)</sup>		8		27	V
$I_{DD}$	Supply Current Inputs / EN Not Connected			1.3	2.0	mA
$V_{ON}$	Turn-On Voltage <sup>(9)</sup>	INA=ENA= $V_{DD}$ , INB=ENB=0V		3.8		V
$V_{HYS}$	Turn-On / Turn-Off Hysteresis <sup>(9)</sup>	INA=ENA= $V_{DD}$ , INB=ENB=0V		10		mV
<b>Input<sup>(9)</sup></b>						
$V_{IL}$	INx Logic Low Threshold		0.8	1.1		V
$V_{IH}$	INx Logic High Threshold			1.80	2.25	V
$V_{HYS}$	Logic Hysteresis Voltage		0.4	0.7	1.0	V
<b>Enable</b>						
$V_{ENL}$	Enable Logic Low Threshold	EN from 5V to 0V	0.8	1.2		V
$V_{ENH}$	Enable Logic High Threshold	EN from 0V to 5V		1.60	2.25	V
$V_{HYS}$	Logic Hysteresis Voltage <sup>(10)</sup>			0.7		V
$R_{PU}$	Enable Pull-Up Resistance			100		k $\Omega$
$t_{D1}$	Propagation A Delay, EN Rising <sup>(11)</sup>	0 - 5V <sub>IN</sub> , 1V/ns Slew Rate		44	70	ns
$t_{D2}$	Propagation A Delay, EN Falling <sup>(11)</sup>	0 - 5V <sub>IN</sub> , 1V/ns Slew Rate		33	60	ns
$t_{D2}$	Propagation B Delay, EN Rising <sup>(11)</sup>	0 - 5V <sub>IN</sub> , 1V/ns Slew Rate		39	70	ns
$t_{D1}$	Propagation B Delay, EN Falling <sup>(11)</sup>	0 - 5V <sub>IN</sub> , 1V/ns Slew Rate		29	60	ns

Continued on the following page...

## Timing Diagrams

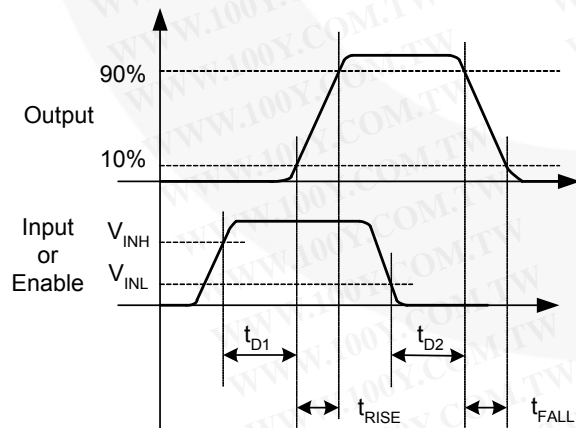

Figure 5. Non-Inverting

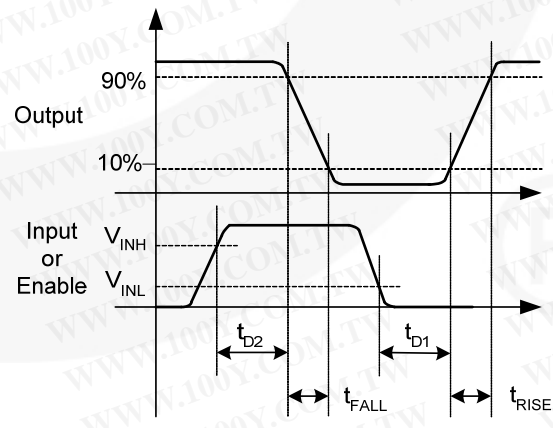

Figure 6. Inverting

**Electrical Characteristics** (Continued)

Unless otherwise noted,  $V_{DD}=12V$  and  $T_J=-40^{\circ}C$  to  $+125^{\circ}C$ . Currents are defined as positive into the device ( $I_{sink}$ ) and negative out of the device ( $I_{source}$ ).

Symbol	Parameter	Conditions	Min.	Typ.	Max.	Unit
<b>Output</b>						
$I_{PK\_OFF}$	OUT Current, Peak, Turn-Off <sup>(10)</sup>	$C_{LOAD}=0.1\mu F$ , $f=1kHz$		1.5		A
$I_{PK\_ON}$	OUT Current, Peak, Turn-On <sup>(10)</sup>	$C_{LOAD}=0.1\mu F$ , $f=1kHz$		-1.0		A
$I_{OFF}$	OUT Current, Mid-Voltage, Turn-Off <sup>(10)</sup>	OUT at $V_{DD}$ , $C_{LOAD}=0.1\mu F$ , $f=1kHz$		1.0		A
$I_{ON}$	OUT Current, Mid-Voltage, Turn-On <sup>(10)</sup>	OUT at $V_{DD}/2$ , $C_{LOAD}=0.1\mu F$ , $f=1kHz$		-0.5		A
$V_{OUTA}$	OUTA Drive Voltage	$V_{DD}=27V$ , INA="HI"		11	13	V
$V_{OUTB}$	OUTB Drive Voltage, $V_{DD} - V_{OUTB}$	$V_{DD}=27V$ , INA="HI"		11	13	V
$V_{OUTA}$	OUTA Drive Voltage	$V_{DD}=10V$ , INB="HI"	6.5	7.0		V
$V_{OUTB}$	OUTB Drive Voltage, $V_{DD} - V_{OUTB}$	$V_{DD}=10V$ , INB="HI"	6.5	7.0		V
$R_{O\_A\_SINK}$	OUTA Sink Impedance (Turn-Off) <sup>(10)</sup>	$V_{DD}=6V$ , $C_{LOAD}=0.1\mu F$		4.2		$\Omega$
$R_{O\_A\_SRC}$	OUTA Source Impedance (Turn-On) <sup>(10)</sup>	$V_{DD}=6V$ , $C_{LOAD}=0.1\mu F$		10.3		$\Omega$
$R_{O\_B\_SINK}$	OUTB Sink Impedance (Turn-On) <sup>(10)</sup>	$V_{DD}=6V$ , $C_{LOAD}=0.1\mu F$		6.8		$\Omega$
$R_{O\_B\_SRC}$	OUTB Source Impedance (Turn-Off) <sup>(10)</sup>	$V_{DD}=6V$ , $C_{LOAD}=0.1\mu F$		13.7		$\Omega$
$t_{ON,N}$	Output A Rise Time <sup>(11)</sup>	$C_{LOAD}=1000pF$ to GND		17	30	ns
$t_{OFF,N}$	Output A Fall Time <sup>(11)</sup>	$C_{LOAD}=1000pF$ to GND		8	15	ns
$t_{ON,P}$	Output B Fall Time <sup>(11)</sup>	$C_{LOAD}=1000pF$ to $V_{DD}$		21	30	ns
$t_{OFF,P}$	Output B Rise Time <sup>(11)</sup>	$C_{LOAD}=1000pF$ to $V_{DD}$		8	15	ns
$t_{D1}$	Output Propagation Delay On <sup>(11)</sup>	0 - 5V <sub>IN</sub> , 1V/ns Slew Rate		45	70	ns
$t_{D2}$	Output Propagation Delay Off <sup>(11)</sup>	0 - 5V <sub>IN</sub> , 1V/ns Slew Rate		35	60	ns
$I_{RVS}$	Output Reverse Current Withstand <sup>(10)</sup>			500		mA

**Notes:**

8. The internal gate-drive regulators provide optimum gate-drive voltage when operating from a rail of 8V to 27V. The FAN3278 can be driven from a voltage rail of less than 8V; however, with reduced gate drive current.
9. EN inputs have near-TTL thresholds (refer to the ENABLE section).
10. Not tested in production.
11. See the Timing Diagrams of Figure 5 and Figure 6.



## Typical Performance Characteristics

Typical characteristics are provided at  $T_A=25^\circ\text{C}$  and  $V_{DD}=12\text{V}$  unless otherwise noted.

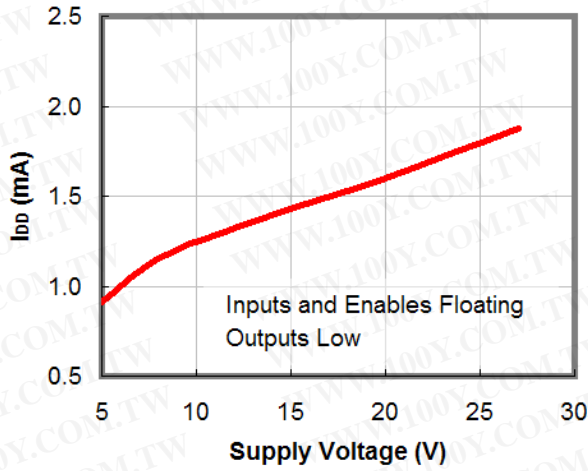

Figure 7.  $I_{DD}$  (Static) vs. Supply Voltage<sup>(12)</sup>

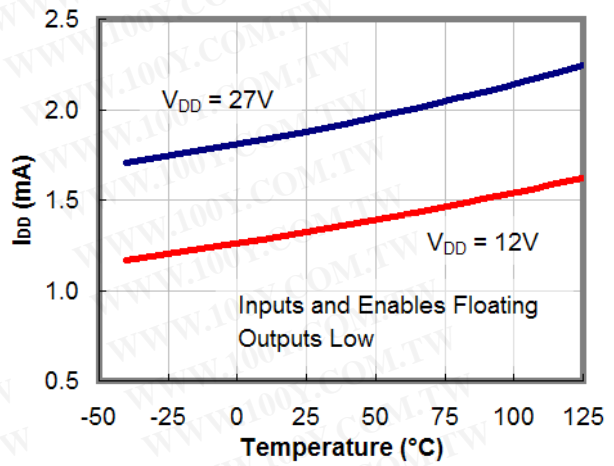

Figure 8.  $I_{DD}$  (Static) vs. Temperature<sup>(12)</sup>

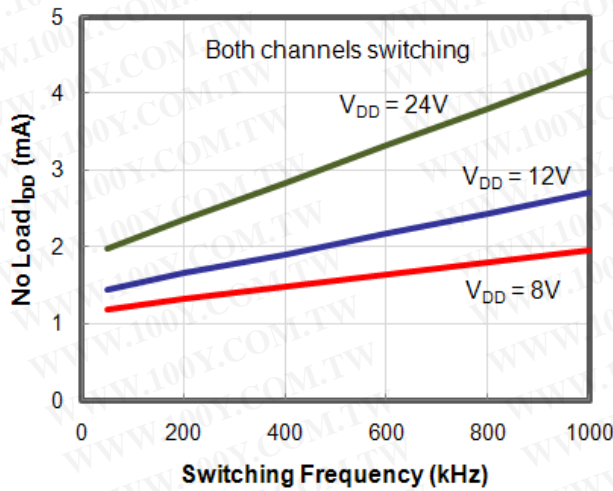

Figure 9.  $I_{DD}$  (No Load) vs. Frequency

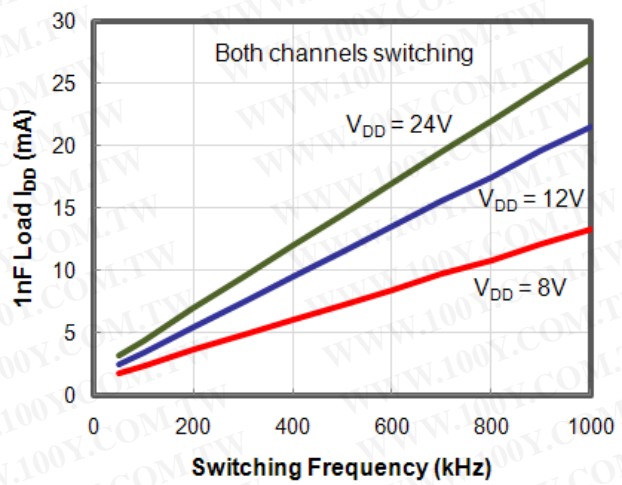

Figure 10.  $I_{DD}$  (1nF Load) vs. Frequency

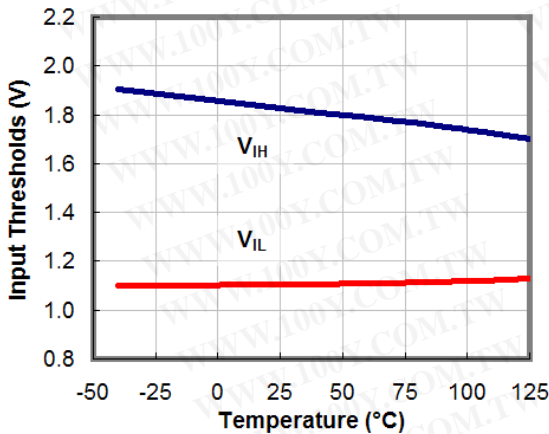

Figure 11. Input Thresholds vs. Temperature



## Typical Performance Characteristics

Typical characteristics are provided at  $T_A=25^\circ\text{C}$  and  $V_{DD}=12\text{V}$  unless otherwise noted.

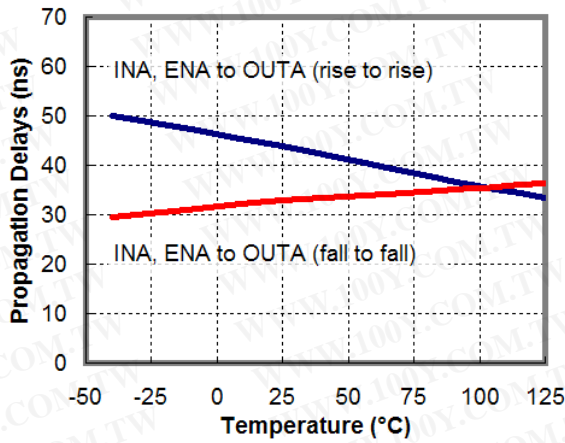

Figure 12. Propagation Delays vs. Temperature

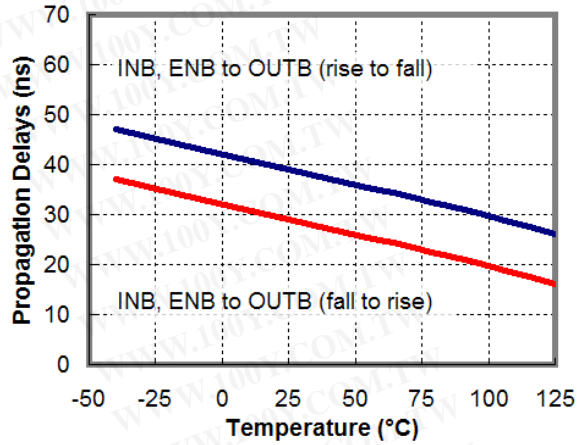

Figure 13. Propagation Delays vs. Temperature

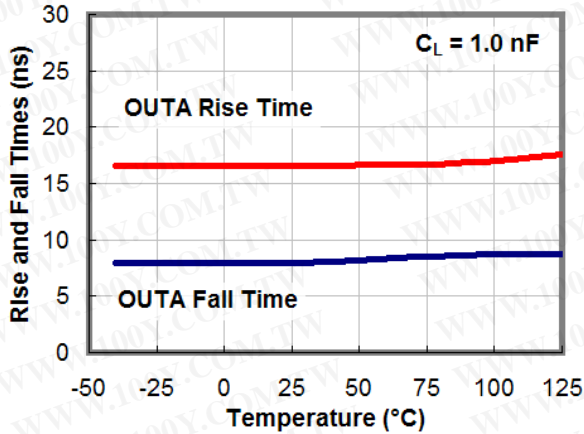

Figure 14. Rise and Fall Times vs. Temperature

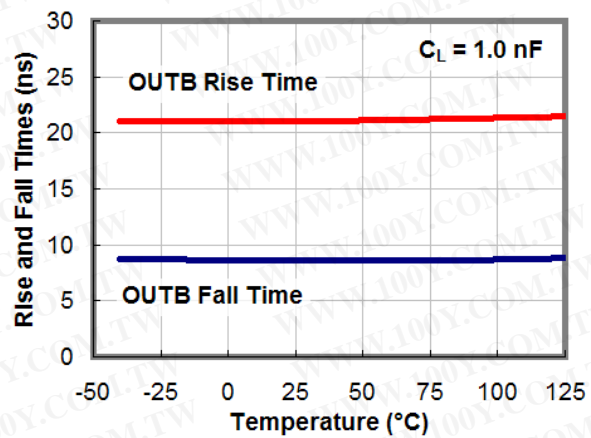

Figure 15. Rise and Fall Times vs. Temperature

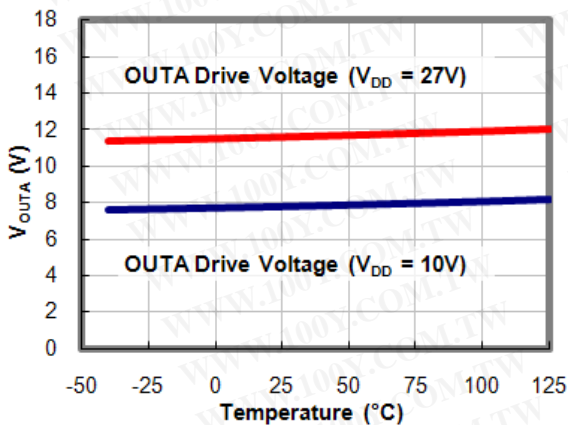

Figure 16. Gate Drive Voltage vs. Temperature

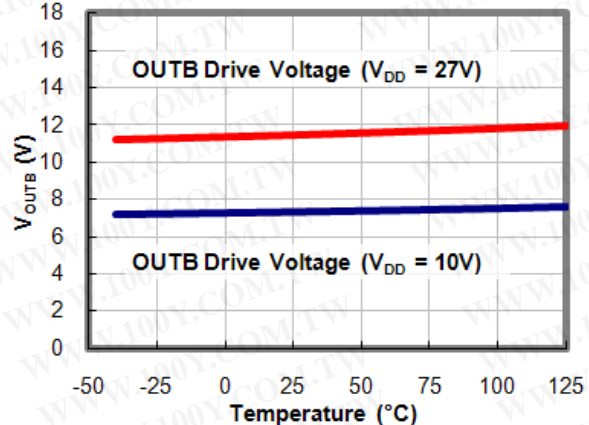

Figure 17. Gate Drive Voltage vs. Temperature

**Note:**

12. For any inverting inputs pulled LOW, non-inverting inputs pulled HIGH, or outputs driven HIGH; static  $I_{DD}$  increases by the current flowing through the corresponding pull-up/down resistor, shown in Figure 4.

## Applications Information

### Input Thresholds

The FAN3278 driver has TTL input thresholds and provides buffer and level translation functions from logic inputs. The input thresholds meet industry-standard TTL-logic thresholds, independent of the  $V_{DD}$  voltage, and there is a hysteresis voltage of approximately 0.4V. These levels permit the inputs to be driven from a range of input logic signal levels for which a voltage over 2V is considered logic HIGH. The driving signal for the TTL inputs should have fast rising and falling edges with a slew rate of  $6V/\mu s$  or faster, so a rise time from 0 to 3.3V should be 550ns or less. With reduced slew rate, circuit noise could cause the driver input voltage to exceed the hysteresis voltage and retrigger the driver input inadvertently.

### Static Supply Current

In the  $I_{DD}$  (static) typical performance characteristics (see Figure 7 and Figure 8), the curve is produced with all inputs / enables floating (OUTA is LOW, OUTB is HIGH) and indicates the lowest static  $I_{DD}$  current for the tested configuration. For other states, additional current flows through the 100k $\Omega$  resistors on the inputs and outputs, shown in the block diagram (see Figure 4). In these cases, the static  $I_{DD}$  current is the value obtained from the curves plus this additional current.

### Gate Drive Regulator

FAN3278 incorporates internal regulators to regulate the gate drive voltage. The output pin slew rate is determined by this gate drive voltage and the load on the output. It is not user adjustable, but a series resistor can be added if a slower rise or fall time is needed at the MOSFET gate.

### Startup Operation

The FAN3278 startup logic is optimized to drive a ground-referenced N-channel MOSFET with channel A and a  $V_{DD}$ -referenced P-channel MOSFET with channel B.

The optimum operating voltage of the FAN3278 is 8V to 27V. It has an internal "watchdog" circuit that provides a loose UVLO turn-on voltage ( $V_{ON}$ ) of approximately 3.8V with a small hysteresis of about 10mV. However, it is recommended that  $V_{DD}$  is greater than 4.75V in all application circuits.

When the  $V_{DD}$  supply voltage is below the level needed to operate the internal circuitry, the outputs are biased to hold the external MOSFETs in OFF state. Internal 100k $\Omega$  resistors bias the non-inverting output LOW and the inverting output to  $V_{DD}$  to keep the external MOSFETs off during startup intervals when input control signals may not be present.

Figure 18 shows startup waveforms for non-inverting channel A. At power-up, the driver output for channel A remains LOW until  $V_{DD}$  reaches the voltage where the device starts operating, then OUTA operates in-phase with INA.

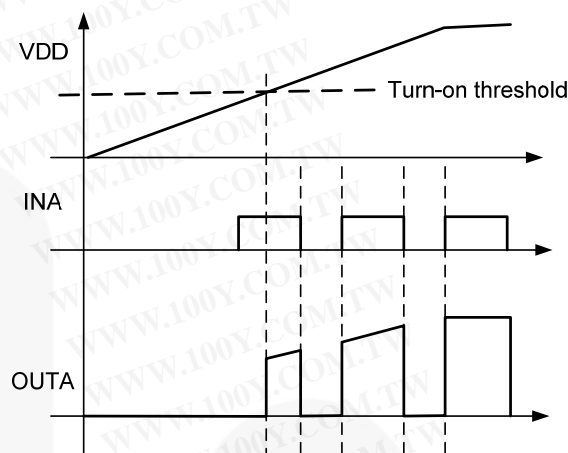

Figure 18. Non-Inverting Startup Waveforms

Figure 19 illustrates startup waveforms for inverting channel B. At power-up, the driver output for channel B is tied to  $V_{DD}$  through an internal 100k $\Omega$  resistor until  $V_{DD}$  reaches the voltage where the device starts operating, then OUTB operates out of phase with INB.

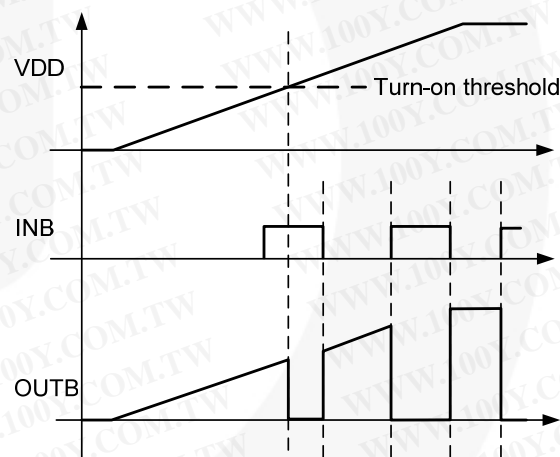

Figure 19. Inverting Startup Waveforms

It is possible, during startup, before  $V_{DD}$  has reached approximately 4.5V, that the output pulse width may take a few switching cycles to reach the full duty-cycle of the input pulse. This is due to internal propagation delays affecting the operation with higher switching frequency (e.g. >100kHz) and slow  $V_{DD}$  ramp-up (e.g. <20V/ms). For this reason, it is recommended that  $V_{DD}$  should be greater than 4.75V before any INA or INB signals are present.

For high-frequency applications (several hundred kHz up to 1MHz), where the above recommendation of  $V_{DD}$  >4.75V is not possible, the use of ENABLEs to actively hold the outputs LOW until  $V_{DD}$  >4.75V assures the driver output pulse width follows the input from 4.75V up to 28V.

### V<sub>DD</sub> Bypass Capacitor Guidelines

To enable this IC to turn a device on quickly, a local high-frequency bypass capacitor, C<sub>BYP</sub>, with low ESR and ESL should be connected between the V<sub>DD</sub> and GND pins with minimal trace length. This capacitor is in addition to bulk electrolytic capacitance of 10μF to 47μF commonly found on driver and controller bias circuits.

A typical criterion for choosing the value of C<sub>BYP</sub> is to keep the ripple voltage on the V<sub>DD</sub> supply to ≤5%. This is often achieved with a value ≥20 times the equivalent load capacitance C<sub>EQV</sub>, defined as Q<sub>GATE</sub>/V<sub>DD</sub>. Ceramic capacitors of 0.1μF to 1μF or larger are common choices, as are dielectrics, such as X5R and X7R, with stable temperature characteristics and high pulse current capability.

If circuit noise affects normal operation, the value of C<sub>BYP</sub> may be increased to 50-100 times the C<sub>EQV</sub> or C<sub>BYP</sub> may be split into two capacitors. One should be a larger value, based on equivalent load capacitance, and the other a smaller value, such as 1-10nF, mounted closest to the V<sub>DD</sub> and GND pins to carry the higher-frequency components of the current pulses. The bypass capacitor must provide the pulsed current from both of the driver channels and, if the drivers are switching simultaneously, the combined peak current sourced from the C<sub>BYP</sub> can be twice as large as when a single channel is switching.

### Layout and Connection Guidelines

The FAN3278 gate driver incorporates fast-reacting input circuits, short propagation delays, and powerful output stages capable of delivering current peaks over 1.5A to facilitate fast voltage transition times. The following layout and connection guidelines are strongly recommended:

- Keep high-current output and power ground paths separate from logic and enable input signals and signal ground paths. This is especially critical when dealing with TTL-level logic thresholds at driver inputs and enable pins.
- Keep the driver as close to the load as possible to minimize the length of high-current traces. This reduces the series inductance to improve high-speed switching, while minimizing the loop area that can couple EMI to the driver inputs and surrounding circuitry.
- If the inputs to a channel are not externally connected, the internal 100kΩ resistors indicated on block diagrams command a low output on channel A and a high output on channel B. In noisy environments, it may be necessary to tie inputs of an unused channel to V<sub>DD</sub> or GND using short traces to prevent noise from causing spurious output switching.
- Many high-speed power circuits can be susceptible to noise injected from their own output or other external sources, possibly causing output mis-triggering. These effects can be obvious if the circuit is tested in breadboard or non-optimal circuit layouts with long input, enable, or output leads. For

best results, make connections to all pins as short and direct as possible.

- The turn-on and turn-off current paths should be minimized, as discussed above.

### Thermal Guidelines

Gate drivers used to switch MOSFETs and IGBTs at high frequencies can dissipate significant amounts of power. It is important to determine the driver power dissipation and the resulting junction temperature in the application to ensure the part is operating within acceptable temperature limits.

The total power dissipation in a gate driver is the sum of two components, P<sub>GATE</sub> and P<sub>DYNAMIC</sub>:

$$P_{TOTAL} = P_{GATE} + P_{DYNAMIC} \quad (1)$$

**Gate Driving Loss:** The most significant power loss results from supplying gate current (charge per unit time) to switch the load MOSFET on and off at the switching frequency. The power dissipation that results from driving a MOSFET with a specified gate-source voltage, V<sub>GS</sub>, with gate charge, Q<sub>G</sub>, at switching frequency, f<sub>SW</sub>, is determined by:

$$P_{GATE} = Q_G \cdot V_{GS} \cdot f_{SW} \quad (2)$$

This needs to be calculated for each P-channel and N-channel MOSFET where the Q<sub>G</sub> is likely to be different.

**Dynamic Pre-drive / Shoot-through Current:** Power loss resulting from internal current consumption under dynamic operating conditions, including pin pull-up / pull-down resistors, can be obtained using the "I<sub>DD</sub> (No-Load) vs. Frequency" graphs in Figure 9 to determine the current I<sub>DYNAMIC</sub> drawn from V<sub>DD</sub> under actual operating conditions.

$$P_{DYNAMIC} = I_{DYNAMIC} \cdot V_{DD} \quad (3)$$

Once the power dissipated in the driver is determined, the driver junction rise with respect to circuit board can be evaluated using the following thermal equation, assuming Ψ<sub>JB</sub> was determined for a similar thermal design (heat sinking and air flow):

$$T_J = P_{TOTAL} \cdot \Psi_{JB} + T_B \quad (4)$$

where:

T<sub>J</sub> = driver junction temperature

Ψ<sub>JB</sub> = (psi) thermal characterization parameter relating temperature rise to total power dissipation

T<sub>B</sub> = board temperature in location defined in Note 1 under Thermal Resistance table.

As an example of a power dissipation calculation, consider an application driving two MOSFETs (one P-channel and one N-channel, both with a gate charge of 60nC each) with V<sub>GS</sub>=V<sub>DD</sub>=12V. At a switching frequency of 200kHz, the total power dissipation is:

$$P_{GATE} = 60nC \cdot 12V \cdot 200kHz \cdot 2 = 0.288W \quad (5)$$

$$P_{DYNAMIC} = 1.65mA \cdot 12V = 0.020W \quad (6)$$

$$P_{TOTAL} = 0.308W \quad (7)$$

The SOIC-8 package has a junction-to-board thermal characterization parameter of  $\Psi_{JB}=43^{\circ}\text{C}/\text{W}$ . In a system application, the localized temperature around the device is a function of the layout and construction of the PCB along with airflow across the surfaces. To ensure reliable operation, the maximum junction temperature of the device must not exceed the absolute maximum rating of  $150^{\circ}\text{C}$ ; with 80% derating,  $T_J$  would be limited to  $120^{\circ}\text{C}$ . Rearranging Equation 4 determines the board temperature required to maintain the junction temperature below  $120^{\circ}\text{C}$ :

$$T_B = T_J - P_{\text{TOTAL}} \cdot \Psi_{JB} \quad (8)$$

$$T_B = 120^{\circ}\text{C} - 0.308\text{W} \cdot 43^{\circ}\text{C}/\text{W} = 107^{\circ}\text{C} \quad (9)$$

### Test Circuit

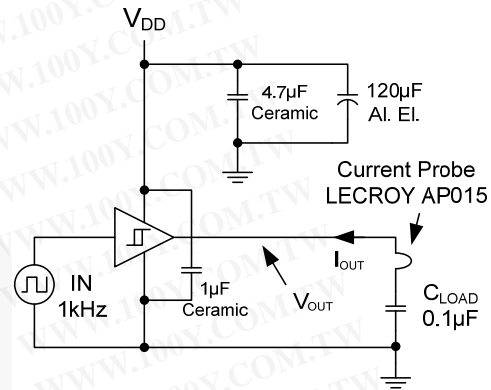

Figure 20. Quasi-Static  $I_{\text{OUT}} / V_{\text{OUT}}$  Test Circuit

### Differences between FAN3278 and FAN3268

FAN3278 and FAN3268 are pin-compatible to each other and are designed to drive one P-Channel and one N-channel MOSFET in applications such as battery-powered compact fan / pump DC motor drives. However, there are key differences, highlighted in Table 1.

Table 1. Differences between FAN3278 and FAN3268

	FAN3278	FAN3268
<b>Supply Voltage</b>	27V Operating Maximum 30V Absolute Maximum	18V Operating Maximum 20V Absolute Maximum
<b>Gate Drive Regulator</b>	Yes, since the maximum operating $V_{DD}$ can be as high as 27V, the gate voltage to the external MOSFETs is limited to about 13V.	No gate drive regulator is needed. The gate drive voltage is $V_{DD}$ and the FAN3268 switches rail-to-rail.
<b>Minimum Operating Voltage</b>	The optimum operating range is 8V to 27V. After the IC turns on at about 3.8V, the output tracks $V_{DD}$ up to the regulated voltage rail of about 11~13V. Below 8V of $V_{DD}$ , the FAN3278 operates, but (a) slower and (b) with limited gate drive voltage until it reaches around 8V.	4.1V is the UVLO turn-off voltage which is the minimum operating voltage.
<b>Startup</b>	The IC starts operating approximately at 3.8V which acts as a loose UVLO threshold. It incorporates a "smart startup" feature where the outputs are held OFF before the IC starts operating.	Has the tight UVLO threshold of 4.5V on / 4.1V off. Incorporates "smart startup" (outputs held OFF before IC is fully operational at the UVLO threshold).
<b>Output Gate Drive Architecture</b>	Standard MOS-based output structure with gate drive clamp.	Compound MillerDrive™ architecture in the final output stage to provide a more efficient gate drive current during the Miller plateau stage of the turn-on/turn-off switching transition.
<b>OUTB Gate Drive Current Strength</b>	Optimized for P-channel: The turn-OFF (1.5 A) is stronger than turn-ON (1.0A).	P-channel turn-ON (2.4A) is stronger than turn-OFF (1.6A).

Table 2. Related Products

Part Number	Type	Gate Drive <sup>(13)</sup> (Sink / Src)	Input Threshold	Logic	Package
FAN3111C	Single 1A	+1.1A / -0.9A	CMOS	Single Channel of Dual-Input/Single-Output	SOT23-5, MLP6
FAN3111E	Single 1A	+1.1A / -0.9A	External <sup>(14)</sup>	Single Non-Inverting Channel with External Reference	SOT23-5, MLP6
FAN3100C	Single 2A	+2.5A / -1.8A	CMOS	Single Channel of Two-Input/One-Output	SOT23-5, MLP6
FAN3100T	Single 2A	+2.5A / -1.8A	TTL	Single Channel of Two-Input/One-Output	SOT23-5, MLP6
FAN3226C	Dual 2A	+2.4A / -1.6A	CMOS	Dual Inverting Channels + Dual Enable	SOIC8, MLP8
FAN3226T	Dual 2A	+2.4A / -1.6A	TTL	Dual Inverting Channels + Dual Enable	SOIC8, MLP8
FAN3227C	Dual 2A	+2.4A / -1.6A	CMOS	Dual Non-Inverting Channels + Dual Enable	SOIC8, MLP8
FAN3227T	Dual 2A	+2.4A / -1.6A	TTL	Dual Non-Inverting Channels + Dual Enable	SOIC8, MLP8
FAN3228C	Dual 2A	+2.4A / -1.6A	CMOS	Dual Channels of Two-Input/One-Output, Pin Config.1	SOIC8, MLP8
FAN3228T	Dual 2A	+2.4A / -1.6A	TTL	Dual Channels of Two-Input/One-Output, Pin Config.1	SOIC8, MLP8
FAN3229C	Dual 2A	+2.4A / -1.6A	CMOS	Dual Channels of Two-Input/One-Output, Pin Config.2	SOIC8, MLP8
FAN3229T	Dual 2A	+2.4A / -1.6A	TTL	Dual Channels of Two-Input/One-Output, Pin Config.2	SOIC8, MLP8
FAN3268T	Dual 2A	+2.4A / -1.6A	TTL	Non-Inverting Channel (NMOS) and Inverting Channel (PMOS) + Dual Enables	SOIC8
<b>FAN3278T</b>	<b>Dual 2A</b>	<b>+1.4A / -1.0A</b>	<b>TTL</b>	<b>30V Non-Inverting (NMOS) and Inverting (PMOS) + Dual Enable</b>	<b>SOIC8</b>
FAN3223C	Dual 4A	+4.3A / -2.8A	CMOS	Dual Inverting Channels + Dual Enable	SOIC8, MLP8
FAN3223T	Dual 4A	+4.3A / -2.8A	TTL	Dual Inverting Channels + Dual Enable	SOIC8, MLP8
FAN3224C	Dual 4A	+4.3A / -2.8A	CMOS	Dual Non-Inverting Channels + Dual Enable	SOIC8, MLP8
FAN3224T	Dual 4A	+4.3A / -2.8A	TTL	Dual Non-Inverting Channels + Dual Enable	SOIC8, MLP8
FAN3225C	Dual 4A	+4.3A / -2.8A	CMOS	Dual Channels of Two-Input/One-Output	SOIC8, MLP8
FAN3225T	Dual 4A	+4.3A / -2.8A	TTL	Dual Channels of Two-Input/One-Output	SOIC8, MLP8
FAN3121C	Single 9A	+9.7A / -7.1A	CMOS	Single Inverting Channel + Enable	SOIC8, MLP8
FAN3121T	Single 9A	+9.7A / -7.1A	TTL	Single Inverting Channel + Enable	SOIC8, MLP8
FAN3122T	Single 9A	+9.7A / -7.1A	CMOS	Single Non-Inverting Channel + Enable	SOIC8, MLP8
FAN3122C	Single 9A	+9.7A / -7.1A	TTL	Single Non-Inverting Channel + Enable	SOIC8, MLP8

**Notes:**13. Typical currents with OUT at 6V and  $V_{DD}=12V$ .

14. Thresholds proportional to an externally supplied reference voltage.



Physical Dimensions

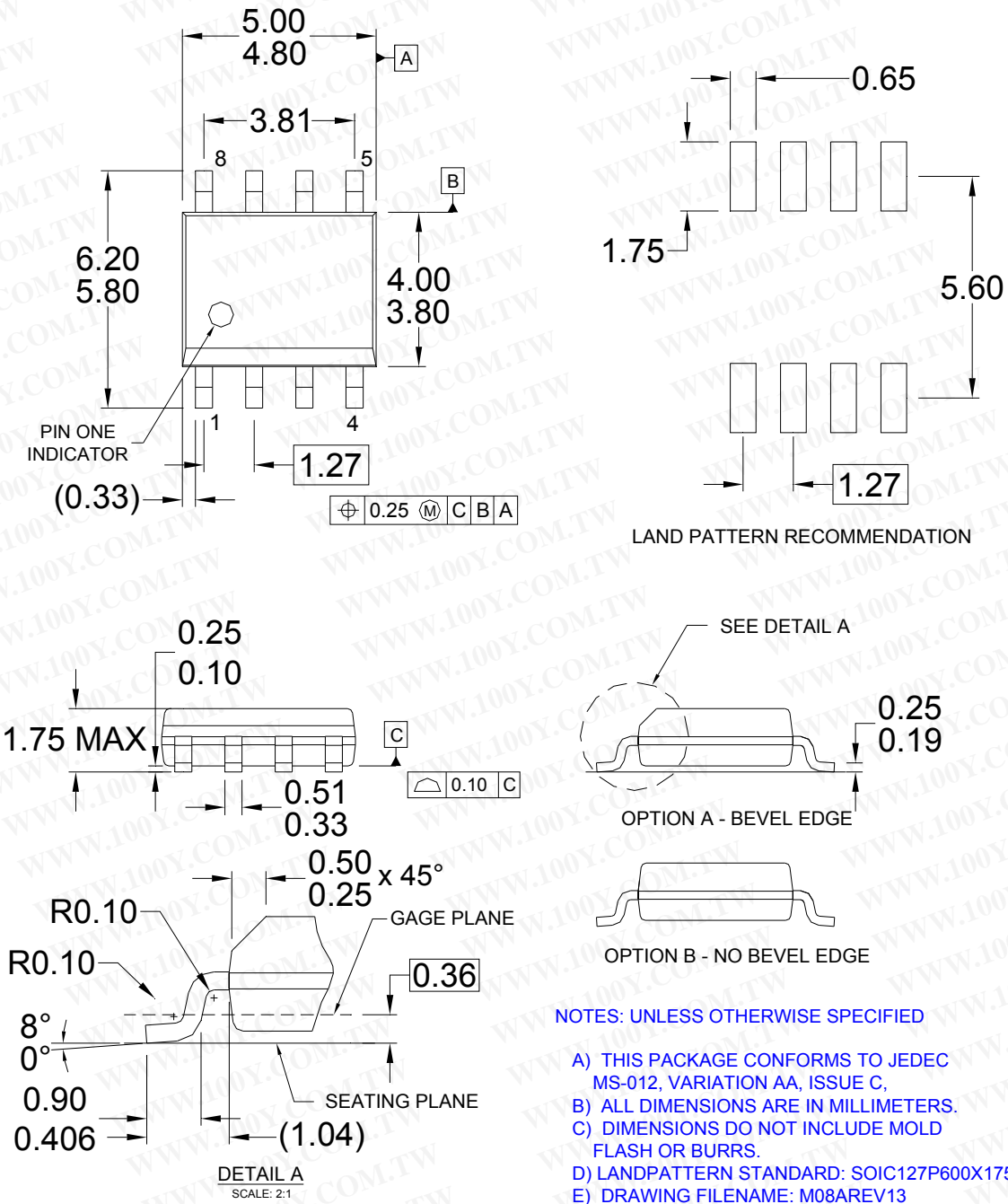

Figure 21. 8-Lead, Small-Outline Integrated Circuit (SOIC)

Package drawings are provided as a service to customers considering Fairchild components. Drawings may change in any manner without notice. Please note the revision and/or date on the drawing and contact a Fairchild Semiconductor representative to verify or obtain the most recent revision. Package specifications do not expand the terms of Fairchild's worldwide terms and conditions, specifically the warranty therein, which covers Fairchild products.

Always visit Fairchild Semiconductor's online packaging area for the most recent package drawings:  
<http://www.fairchildsemi.com/packaging/>.





勝特力材料 886-3-5753170  
 勝特力电子(上海) 86-21-34970699  
 勝特力电子(深圳) 86-755-83298787  
 Http://www.100y.com.tw



**TRADEMARKS**

The following includes registered and unregistered trademarks and service marks, owned by Fairchild Semiconductor and/or its global subsidiaries, and is not intended to be an exhaustive list of all such trademarks.

- |  |  |   |   |
|--|--|---|---|
| 2Cool™   | F-PFS™   | PowerTrench®  | The Power Franchise®  |
| AccuPower™   | FRFET®   | PowerXS™  | the p <sup>er</sup> franchise   |
| AX-CAP™*   | Global Power Resource™                         | Programmable Active Droop™  | TinyBoost™  |
| BitSiC™  | GreenBridge™                                   | QFET®   | TinyBuck™   |
| Build it Now™  | Green FPS™                                     | QS™   | TinyCalc™   |
| CorePLUS™  | Green FPS™ e-Series™                           | Quiet Series™   | TinyLogic®  |
| CorePOWER™   | Gmax™  | RapidConfigure™   | TINYOPTO™   |
| CROSSVOLT™   | GTO™   |  | TinyPower™  |
| CTL™   | IntelliMAX™                                    | Saving our world, 1mW/W/kW at a time™   | TinyPWM™  |
| Current Transfer Logic™  | ISOPLANAR™                                     | SignalWise™   | TinyWire™   |
| DEUXPEED®  | Making Small Speakers Sound Louder and Better™ | SmartMax™   | TranSiC™  |
| Dual Cool™   | MegaBuck™                                      | SMART START™  | TriFault Detect™  |
| EcoSPARK®  | MICROCOUPLER™                                  | Solutions for Your Success™   | TRUECURRENT®*   |
| EfficientMax™  | MicroFET™                                      | SPM®  | µSerDes™  |
| ESBC™  | MicroPak™                                      | STEALTH™  |  |
|  Fairchild® | MicroPak2™                                     | SuperFET®   | UHC™  |
| Fairchild Semiconductor®   | MillerDrive™                                   | SuperSOT™-3   | Ultra FRFET™  |
| FACT Quiet Series™   | MotionMax™                                     | SuperSOT™-6   | UniFET™   |
| FACT®  | mWSaver™                                       | SupreMOS®   | VCX™  |
| FAST®  | OptoHi™  | SyncFET™  | VisualMax™  |
| FastvCore™   | OPTOLOGIC®                                     | Sync-Lock™  | VoltagePlus™  |
| FETBench™  | OPTOPLANAR®                                    |  | XS™   |
| FlashWriter®*  |  |   |   |
| FPS™   |  |   |   |

\* Trademarks of System General Corporation, used under license by Fairchild Semiconductor.

**DISCLAIMER**

FAIRCHILD SEMICONDUCTOR RESERVES THE RIGHT TO MAKE CHANGES WITHOUT FURTHER NOTICE TO ANY PRODUCTS HEREIN TO IMPROVE RELIABILITY, FUNCTION, OR DESIGN. FAIRCHILD DOES NOT ASSUME ANY LIABILITY ARISING OUT OF THE APPLICATION OR USE OF ANY PRODUCT OR CIRCUIT DESCRIBED HEREIN; NEITHER DOES IT CONVEY ANY LICENSE UNDER ITS PATENT RIGHTS, NOR THE RIGHTS OF OTHERS. THESE SPECIFICATIONS DO NOT EXPAND THE TERMS OF FAIRCHILD'S WORLDWIDE TERMS AND CONDITIONS, SPECIFICALLY THE WARRANTY THEREIN, WHICH COVERS THESE PRODUCTS.

**LIFE SUPPORT POLICY**

FAIRCHILD'S PRODUCTS ARE NOT AUTHORIZED FOR USE AS CRITICAL COMPONENTS IN LIFE SUPPORT DEVICES OR SYSTEMS WITHOUT THE EXPRESS WRITTEN APPROVAL OF FAIRCHILD SEMICONDUCTOR CORPORATION.

As used herein:

1. Life support devices or systems are devices or systems which, (a) are intended for surgical implant into the body or (b) support or sustain life, and (c) whose failure to perform when properly used in accordance with instructions for use provided in the labeling, can be reasonably expected to result in a significant injury of the user.
2. A critical component in any component of a life support, device, or system whose failure to perform can be reasonably expected to cause the failure of the life support device or system, or to affect its safety or effectiveness.

**ANTI-COUNTERFEITING POLICY**

Fairchild Semiconductor Corporation's Anti-Counterfeiting Policy. Fairchild's Anti-Counterfeiting Policy is also stated on our external website, www.fairchildsemi.com, under Sales Support.

Counterfeiting of semiconductor parts is a growing problem in the industry. All manufacturers of semiconductor products are experiencing counterfeiting of their parts. Customers who inadvertently purchase counterfeit parts experience many problems such as loss of brand reputation, substandard performance, failed applications, and increased cost of production and manufacturing delays. Fairchild is taking strong measures to protect ourselves and our customers from the proliferation of counterfeit parts. Fairchild strongly encourages customers to purchase Fairchild parts either directly from Fairchild or from Authorized Fairchild Distributors who are listed by country on our web page cited above. Products customers buy either from Fairchild directly or from Authorized Fairchild Distributors are genuine parts, have full traceability, meet Fairchild's quality standards for handling and storage and provide access to Fairchild's full range of up-to-date technical and product information. Fairchild and our Authorized Distributors will stand behind all warranties and will appropriately address any warranty issues that may arise. Fairchild will not provide any warranty coverage or other assistance for parts bought from Unauthorized Sources. Fairchild is committed to combat this global problem and encourage our customers to do their part in stopping this practice by buying direct or from authorized distributors.

**PRODUCT STATUS DEFINITIONS**

**Definition of Terms**

Datasheet Identification	Product Status	Definition
Advance Information	Formative / In Design	Datasheet contains the design specifications for product development. Specifications may change in any manner without notice.
Preliminary	First Production	Datasheet contains preliminary data; supplementary data will be published at a later date. Fairchild Semiconductor reserves the right to make changes at any time without notice to improve design.
No Identification Needed	Full Production	Datasheet contains final specifications. Fairchild Semiconductor reserves the right to make changes at any time without notice to improve the design.
Obsolete	Not In Production	Datasheet contains specifications on a product that is discontinued by Fairchild Semiconductor. The datasheet is for reference information only.

Rev. I62