

# SN75ALS174A QUADRUPLE DIFFERENTIAL LINE DRIVER

SLLS122E – JULY 1991 – REVISED APRIL 1998

- Meets or Exceeds the Requirements of ANSI EIA/TIA-422-B and RS-485
- High-Speed Advanced Low-Power Schottky Circuitry
- Designed for up to 20-Mbit/s Operation in Both Serial and Parallel Applications
- Designed for Multipoint Transmission on Long Bus Lines in Noisy Environments
- Low Supply Current Requirements  
55 mA Max
- Wide Positive and Negative Input/Output Bus Voltage Ranges
- Driver Output Capacity . . .  $\pm 60$  mA
- Thermal-Shutdown Protection
- Driver Positive- and Negative-Current Limiting
- Functionally Interchangeable With SN75174

## description

The SN75ALS174A is a quadruple line driver with 3-state differential outputs. It is designed to meet the requirements of ANSI Standards EIA/TIA-422-B and RS-485. This device is optimized for balanced multipoint bus transmission at rates of up to 20 Mbit/s. Each driver features wide positive and negative common-mode output voltage ranges that make them suitable for party-line applications in noisy environments.

The SN75ALS174A provides positive- and negative-current limiting and thermal shutdown for protection from line fault conditions on the transmission bus line. Shutdown occurs at a junction temperature of approximately 150°C.

The SN75ALS174A is characterized for operation from 0°C to 70°C.

FUNCTION TABLE  
(each driver)

INPUT A	ENABLES	OUTPUTS	
		Y	Z
H	H	H	L
L	H	L	H
X	L	Z	Z

H = high level, L = low level, X = irrelevant,  
Z = high impedance (off)

N PACKAGE  
(TOP VIEW)

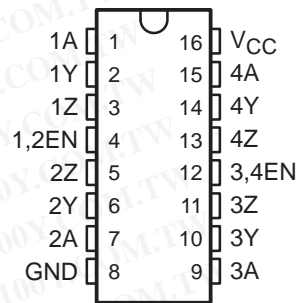

DW PACKAGE  
(TOP VIEW)

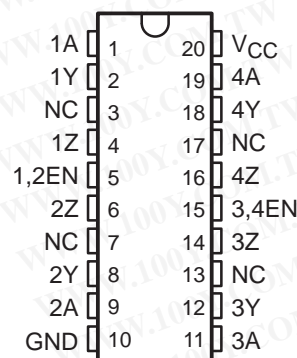

NC – No internal connection



Please be aware that an important notice concerning availability, standard warranty, and use in critical applications of Texas Instruments semiconductor products and disclaimers thereto appears at the end of this data sheet.

PRODUCTION DATA information is current as of publication date. Products conform to specifications per the terms of Texas Instruments standard warranty. Production processing does not necessarily include testing of all parameters.

 **TEXAS  
INSTRUMENTS**

POST OFFICE BOX 655303 • DALLAS, TEXAS 75265

Copyright © 1998, Texas Instruments Incorporated

勝特力材料 886-3-5753170  
勝特力电子(上海) 86-21-34970699  
勝特力电子(深圳) 86-755-83298787  
[Http://www.100y.com.tw](http://www.100y.com.tw)

# SN75ALS174A QUADRUPLE DIFFERENTIAL LINE DRIVER

SLLS122E – JULY 1991 – REVISED APRIL 1998

## logic symbol†

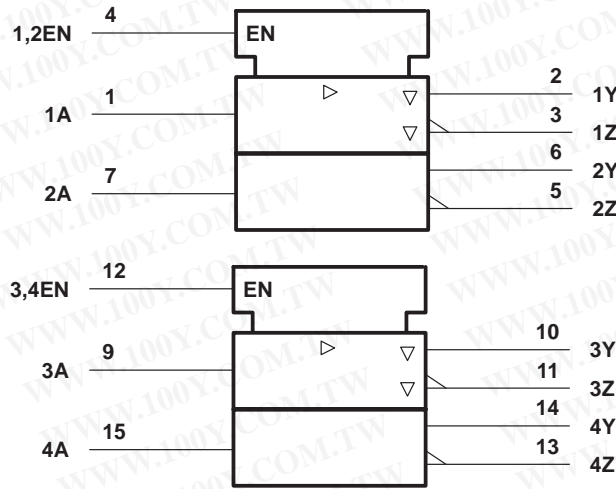

† This symbol is in accordance with ANSI/IEEE Std 91-1984 and IEC Publication 617-12. Pin numbers shown are for the N package.

## logic diagram (positive logic)

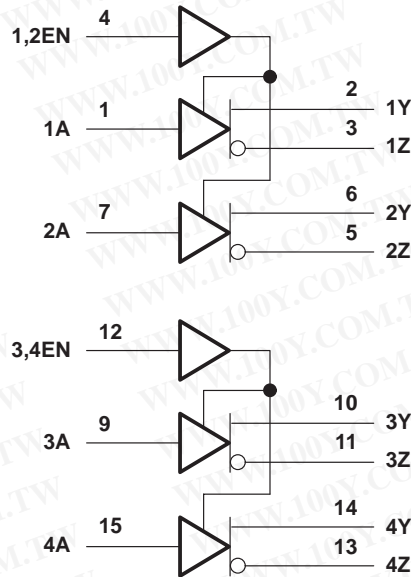

Pin numbers shown are for the N package.

勝特力材料 886-3-5753170  
 勝特力电子(上海) 86-21-34970699  
 勝特力电子(深圳) 86-755-83298787  
[Http://www.100y.com.tw](http://www.100y.com.tw)

schematics of inputs and outputs

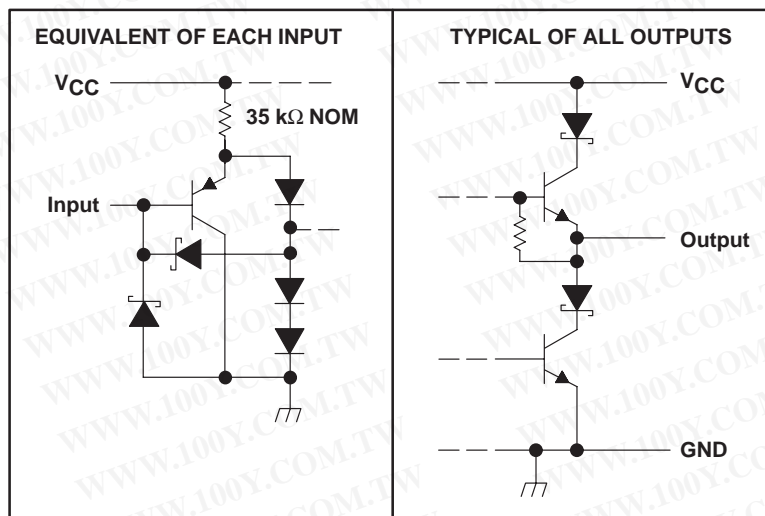

absolute maximum ratings over operating free-air temperature range (unless otherwise noted)†

Supply voltage, $V_{CC}$ (see Note 1)	7 V
Input voltage, $V_I$	7 V
Output voltage range, $V_O$	-9 V to 14 V
Continuous total dissipation	See Dissipation Rating Table
Storage temperature range, $T_{stg}$	-65°C to 150°C
Lead temperature 1,6 mm (1/16 inch) from case for 10 seconds	260°C

† Stresses beyond those listed under “absolute maximum ratings” may cause permanent damage to the device. These are stress ratings only, and functional operation of the device at these or any other conditions beyond those indicated under “recommended operating conditions” is not implied. Exposure to absolute-maximum-rated conditions for extended periods may affect device reliability.

NOTE 1: All voltage values are with respect to network GND.

DISSIPATION RATING TABLE

PACKAGE	$T_A \leq 25^\circ\text{C}$ POWER RATING	DERATING FACTOR	$T_A = 70^\circ\text{C}$ POWER RATING	$T_A = 85^\circ\text{C}$ POWER RATING
DW	1125 mW	9.0 mW/°C	720 mW	585 mW
N	1150 mW	9.2 mW/°C	736 mW	598 mW

recommended operating conditions

	MIN	NOM	MAX	UNIT
Supply voltage, $V_{CC}$	4.75	5	5.25	V
High-level input voltage, $V_{IH}$	2			V
Low-level input voltage, $V_{IL}$			0.8	V
Common-mode output voltage, $V_{OC}$			12 -7	V
High-level output current, $I_{OH}$			-60	mA
Low-level output current, $I_{OL}$			60	mA
Operating free-air temperature, $T_A$	0		70	°C

# SN75ALS174A

## QUADRUPLE DIFFERENTIAL LINE DRIVER

SLLS122E – JULY 1991 – REVISED APRIL 1998

### electrical characteristics over recommended ranges of supply voltage and operating free-air temperature (unless otherwise noted)

PARAMETER		TEST CONDITIONS		MIN	TYP†	MAX	UNIT
V <sub>IK</sub>	Input clamp voltage	I <sub>I</sub> = -18 mA				-1.5	V
V <sub>O</sub>	Output voltage	I <sub>O</sub> = 0		0		6	V
V <sub>OD1</sub>	Differential output voltage	I <sub>O</sub> = 0		1.5		6	V
V <sub>OD2</sub>	Differential output voltage	R <sub>L</sub> = 100 Ω	See Figure 1	1/2V <sub>OD1</sub> or 2‡			V
		R <sub>L</sub> = 54 Ω		1.5	2.5	5	
V <sub>OD3</sub>	Differential output voltage	See Note 2		1.5		5	V
Δ V <sub>OD</sub>	Change in magnitude of differential output voltage§	R <sub>L</sub> = 54 Ω or 100 Ω,	See Figure 1			±0.2	V
V <sub>OC</sub>	Common-mode output voltage¶	R <sub>L</sub> = 54 Ω or 100 Ω,	See Figure 1			3 -1	V
Δ V <sub>OC</sub>	Change in magnitude of common-mode output voltage§	R <sub>L</sub> = 54 Ω or 100 Ω,	See Figure 1			±0.2	V
I <sub>O</sub>	Output current with power off	V <sub>CC</sub> = 0,	V <sub>O</sub> = -7 V to 12 V			±100	μA
I <sub>OZ</sub>	High-impedance-state output current	V <sub>O</sub> = -7 V to 12 V				±100	μA
I <sub>IH</sub>	High-level input current	V <sub>I</sub> = 2.7 V				20	μA
I <sub>IL</sub>	Low-level input current	V <sub>I</sub> = 0.4 V				-100	μA
I <sub>OS</sub>	Short-circuit output current	V <sub>O</sub> = -7 V to 12 V				±250	mA
I <sub>CC</sub>	Supply current (all drivers)	No load	Outputs enabled		36	55	mA
			Outputs disabled		16	30	

† All typical values are at V<sub>CC</sub> = 5 V and T<sub>A</sub> = 25°C.

‡ The minimum V<sub>OD2</sub> with a 100-Ω load is either 1/2 V<sub>OD1</sub> or 2 V, whichever is greater.

§ Δ|V<sub>OD</sub>| and Δ|V<sub>OC</sub>| are the changes in magnitude of V<sub>OD</sub> and V<sub>OC</sub>, respectively, that occur when the input is changed from a high level to a low level.

¶ In ANSI Standard EIA/TIA-422-B, V<sub>OC</sub>, which is the average of the two output voltages with respect to ground, is called output offset voltage, V<sub>OS</sub>.

NOTE 2: See EIA Standard RS-485, Figure 3-5, Test Termination Measurement 2.

### switching characteristics over recommended ranges of supply voltage and operating free-air temperature, C<sub>L</sub> = 50 pF

PARAMETER		TEST CONDITIONS		MIN	TYP†	MAX	UNIT
t <sub>d(OD)</sub>	Differential output delay time	R <sub>L</sub> = 54 Ω,	See Figure 2	9	15	22	ns
t <sub>PZH</sub>	Output enable time to high level	R <sub>L</sub> = 110 Ω,	See Figure 3	30	45	70	ns
t <sub>PZL</sub>	Output enable time to low level	R <sub>L</sub> = 110 Ω,	See Figure 4	25	40	65	ns
t <sub>PHZ</sub>	Output disable time from high level	R <sub>L</sub> = 110 Ω,	See Figure 3	10	20	35	ns
t <sub>PLZ</sub>	Output disable time from low level	R <sub>L</sub> = 110 Ω,	See Figure 4	10	30	45	ns

† All typical values are at V<sub>CC</sub> = 5 V and T<sub>A</sub> = 25°C.

勝特力材料 886-3-5753170  
 勝特力电子(上海) 86-21-34970699  
 勝特力电子(深圳) 86-755-83298787  
[Http://www.100y.com.tw](http://www.100y.com.tw)





PARAMETER MEASUREMENT INFORMATION

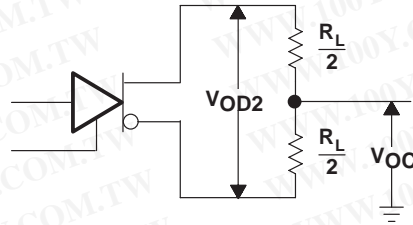
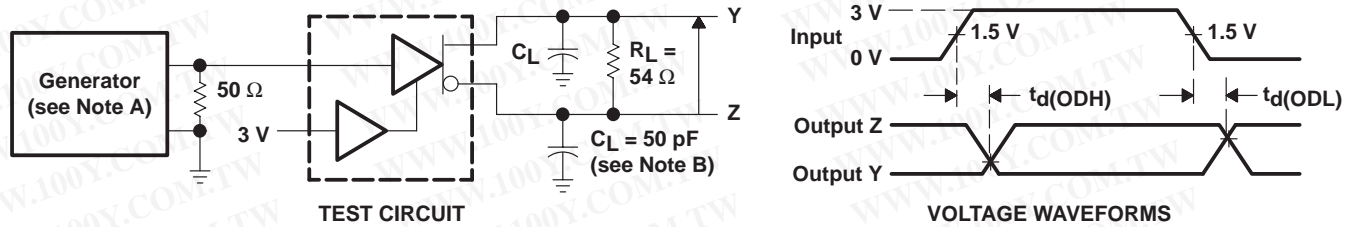
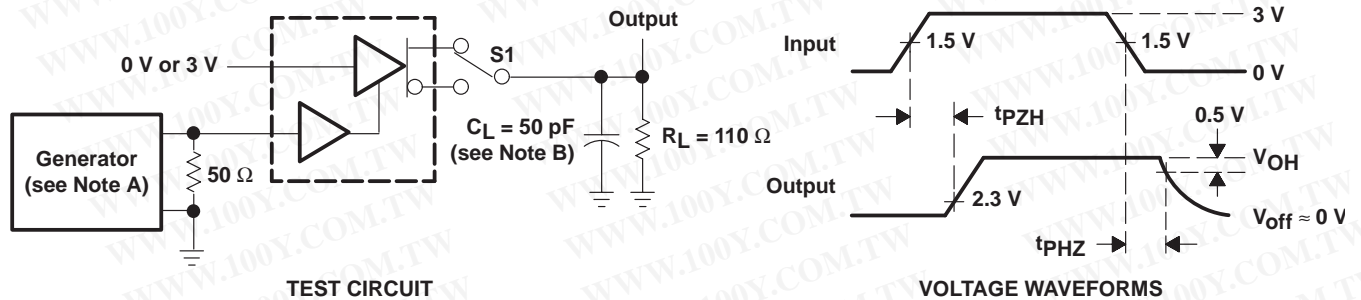

Figure 1. Differential and Common-Mode Output Voltages



NOTES: A. The input pulse is supplied by a generator having the following characteristics: PRR = 1 MHz,  $Z_O = 50 \Omega$ , duty cycle = 50%,  $t_r \leq 5$  ns,  $t_f \leq 5$  ns.  
 B.  $C_L$  includes probe and stray capacitance.

Figure 2. Differential-Output Test Circuit and Delay and Transition Times Voltage Waveforms



NOTES: A. The input pulse is supplied by a generator having the following characteristics: PRR = 1 MHz,  $Z_O = 50 \Omega$ , duty cycle = 50%,  $t_r \leq 5$  ns,  $t_f \leq 5$  ns.  
 B.  $C_L$  includes probe and stray capacitance.

Figure 3. Test Circuit and Voltage Waveforms,  $t_{pZH}$  and  $t_{pHZ}$

勝特力材料 886-3-5753170  
 勝特力电子(上海) 86-21-34970699  
 勝特力电子(深圳) 86-755-83298787  
[Http://www.100y.com.tw](http://www.100y.com.tw)

# SN75ALS174A QUADRUPLE DIFFERENTIAL LINE DRIVER

SLLS122E – JULY 1991 – REVISED APRIL 1998

## PARAMETER MEASUREMENT INFORMATION

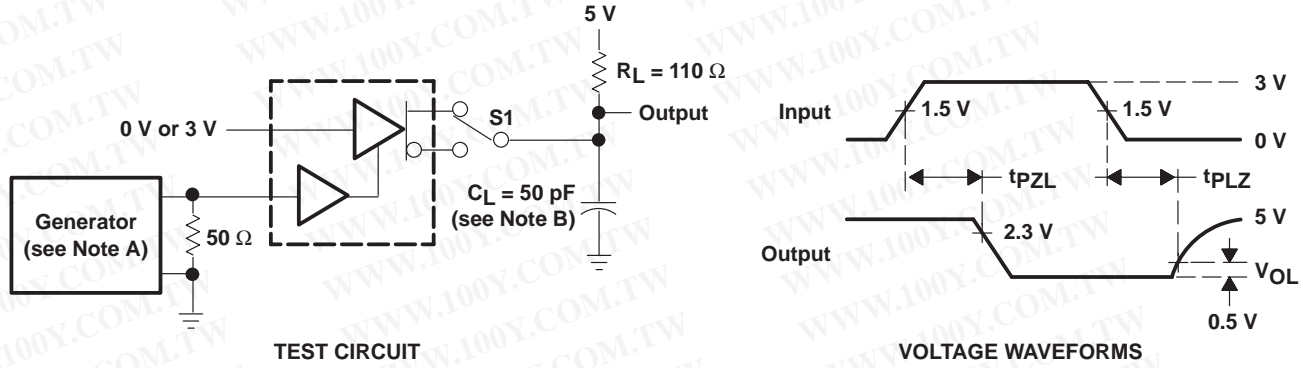

- NOTES: A. The input pulse is supplied by a generator having the following characteristics: PRR = 1 MHz,  $Z_O = 50 \Omega$ , duty cycle = 50%,  $t_f \leq 5 \text{ ns}$ ,  $t_r \leq 5 \text{ ns}$ .  
B.  $C_L$  includes probe and stray capacitance.

Figure 4. Test Circuit and Voltage Waveforms,  $t_{pZL}$  and  $t_{pLZ}$

勝特力材料 886-3-5753170  
 勝特力电子(上海) 86-21-34970699  
 勝特力电子(深圳) 86-755-83298787  
[Http://www.100y.com.tw](http://www.100y.com.tw)

**PACKAGING INFORMATION**

Orderable Device	Status <sup>(1)</sup>	Package Type	Package Drawing	Pins	Package Qty	Eco Plan <sup>(2)</sup>	Lead/Ball Finish	MSL Peak Temp <sup>(3)</sup>
SN75ALS174ADW	ACTIVE	SOIC	DW	20	25	Green (RoHS & no Sb/Br)	CU NIPDAU	Level-1-260C-UNLIM
SN75ALS174ADWE4	ACTIVE	SOIC	DW	20	25	Green (RoHS & no Sb/Br)	CU NIPDAU	Level-1-260C-UNLIM
SN75ALS174ADWG4	ACTIVE	SOIC	DW	20	25	Green (RoHS & no Sb/Br)	CU NIPDAU	Level-1-260C-UNLIM
SN75ALS174ADWR	ACTIVE	SOIC	DW	20	2000	Green (RoHS & no Sb/Br)	CU NIPDAU	Level-1-260C-UNLIM
SN75ALS174ADWRE4	ACTIVE	SOIC	DW	20	2000	Green (RoHS & no Sb/Br)	CU NIPDAU	Level-1-260C-UNLIM
SN75ALS174ADWRG4	ACTIVE	SOIC	DW	20	2000	Green (RoHS & no Sb/Br)	CU NIPDAU	Level-1-260C-UNLIM
SN75ALS174AN	ACTIVE	PDIP	N	16	25	Pb-Free (RoHS)	CU NIPD	N / A for Pkg Type
SN75ALS174ANE4	ACTIVE	PDIP	N	16	25	Pb-Free (RoHS)	CU NIPD	N / A for Pkg Type

<sup>(1)</sup> The marketing status values are defined as follows:

**ACTIVE:** Product device recommended for new designs.

**LIFEBUY:** TI has announced that the device will be discontinued, and a lifetime-buy period is in effect.

**NRND:** Not recommended for new designs. Device is in production to support existing customers, but TI does not recommend using this part in a new design.

**PREVIEW:** Device has been announced but is not in production. Samples may or may not be available.

**OBSOLETE:** TI has discontinued the production of the device.

<sup>(2)</sup> Eco Plan - The planned eco-friendly classification: Pb-Free (RoHS), Pb-Free (RoHS Exempt), or Green (RoHS & no Sb/Br) - please check <http://www.ti.com/productcontent> for the latest availability information and additional product content details.

**TBD:** The Pb-Free/Green conversion plan has not been defined.

**Pb-Free (RoHS):** TI's terms "Lead-Free" or "Pb-Free" mean semiconductor products that are compatible with the current RoHS requirements for all 6 substances, including the requirement that lead not exceed 0.1% by weight in homogeneous materials. Where designed to be soldered at high temperatures, TI Pb-Free products are suitable for use in specified lead-free processes.

**Pb-Free (RoHS Exempt):** This component has a RoHS exemption for either 1) lead-based flip-chip solder bumps used between the die and package, or 2) lead-based die adhesive used between the die and leadframe. The component is otherwise considered Pb-Free (RoHS compatible) as defined above.

**Green (RoHS & no Sb/Br):** TI defines "Green" to mean Pb-Free (RoHS compatible), and free of Bromine (Br) and Antimony (Sb) based flame retardants (Br or Sb do not exceed 0.1% by weight in homogeneous material)

<sup>(3)</sup> MSL, Peak Temp. -- The Moisture Sensitivity Level rating according to the JEDEC industry standard classifications, and peak solder temperature.

**Important Information and Disclaimer:**The information provided on this page represents TI's knowledge and belief as of the date that it is provided. TI bases its knowledge and belief on information provided by third parties, and makes no representation or warranty as to the accuracy of such information. Efforts are underway to better integrate information from third parties. TI has taken and continues to take reasonable steps to provide representative and accurate information but may not have conducted destructive testing or chemical analysis on incoming materials and chemicals. TI and TI suppliers consider certain information to be proprietary, and thus CAS numbers and other limited information may not be available for release.

In no event shall TI's liability arising out of such information exceed the total purchase price of the TI part(s) at issue in this document sold by TI to Customer on an annual basis.

勝特力材料 886-3-5753170  
 勝特力电子(上海) 86-21-34970699  
 勝特力电子(深圳) 86-755-83298787  
[Http://www.100y.com.tw](http://www.100y.com.tw)

**TAPE AND REEL INFORMATION**

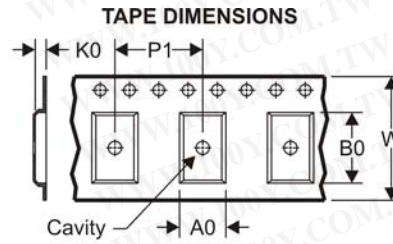
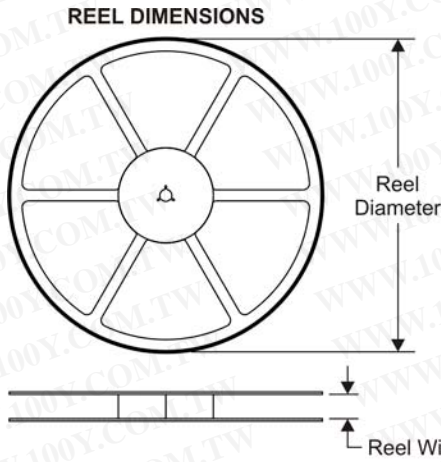

A0	Dimension designed to accommodate the component width
B0	Dimension designed to accommodate the component length
K0	Dimension designed to accommodate the component thickness
W	Overall width of the carrier tape
P1	Pitch between successive cavity centers

**QUADRANT ASSIGNMENTS FOR PIN 1 ORIENTATION IN TAPE**

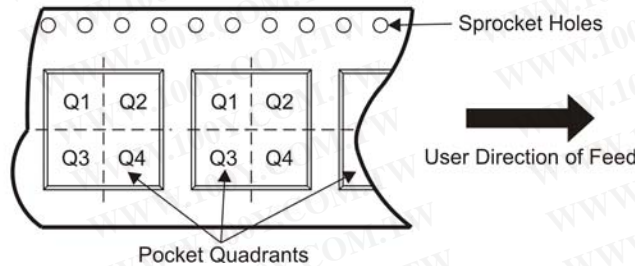

\*All dimensions are nominal

Device	Package Type	Package Drawing	Pins	SPQ	Reel Diameter (mm)	Reel Width W1 (mm)	A0 (mm)	B0 (mm)	K0 (mm)	P1 (mm)	W (mm)	Pin1 Quadrant
SN75ALS174ADWR	SOIC	DW	20	2000	330.0	24.4	10.8	13.1	2.65	12.0	24.0	Q1

勝特力材料 886-3-5753170  
 勝特力电子(上海) 86-21-34970699  
 勝特力电子(深圳) 86-755-83298787  
[Http://www.100y.com.tw](http://www.100y.com.tw)



**TAPE AND REEL BOX DIMENSIONS**

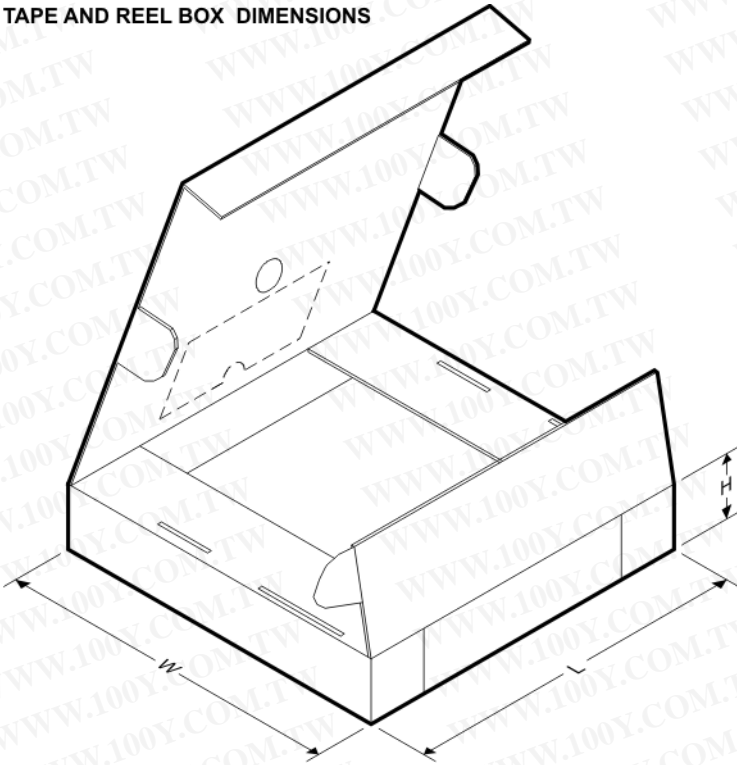

\*All dimensions are nominal

Device	Package Type	Package Drawing	Pins	SPQ	Length (mm)	Width (mm)	Height (mm)
SN75ALS174ADWR	SOIC	DW	20	2000	346.0	346.0	41.0

勝特力材料 886-3-5753170  
 勝特力电子(上海) 86-21-34970699  
 勝特力电子(深圳) 86-755-83298787  
[Http://www.100y.com.tw](http://www.100y.com.tw)

DW (R-PDSO-G20)

PLASTIC SMALL-OUTLINE PACKAGE

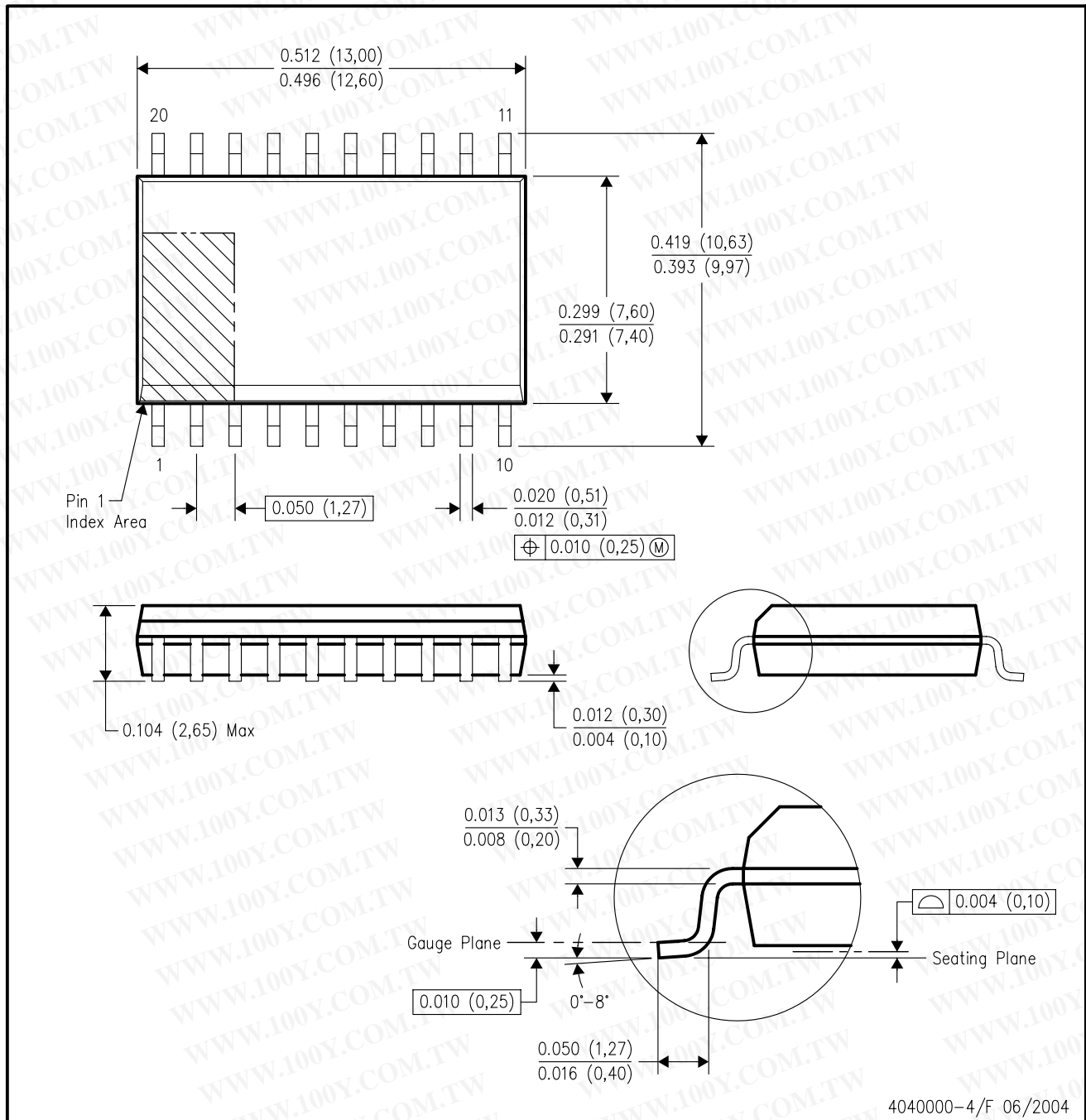

4040000-4/F 06/2004

- NOTES:
- A. All linear dimensions are in inches (millimeters).
  - B. This drawing is subject to change without notice.
  - C. Body dimensions do not include mold flash or protrusion not to exceed 0.006 (0,15).
  - D. Falls within JEDEC MS-013 variation AC.

N (R-PDIP-T\*\*)

PLASTIC DUAL-IN-LINE PACKAGE

16 PINS SHOWN

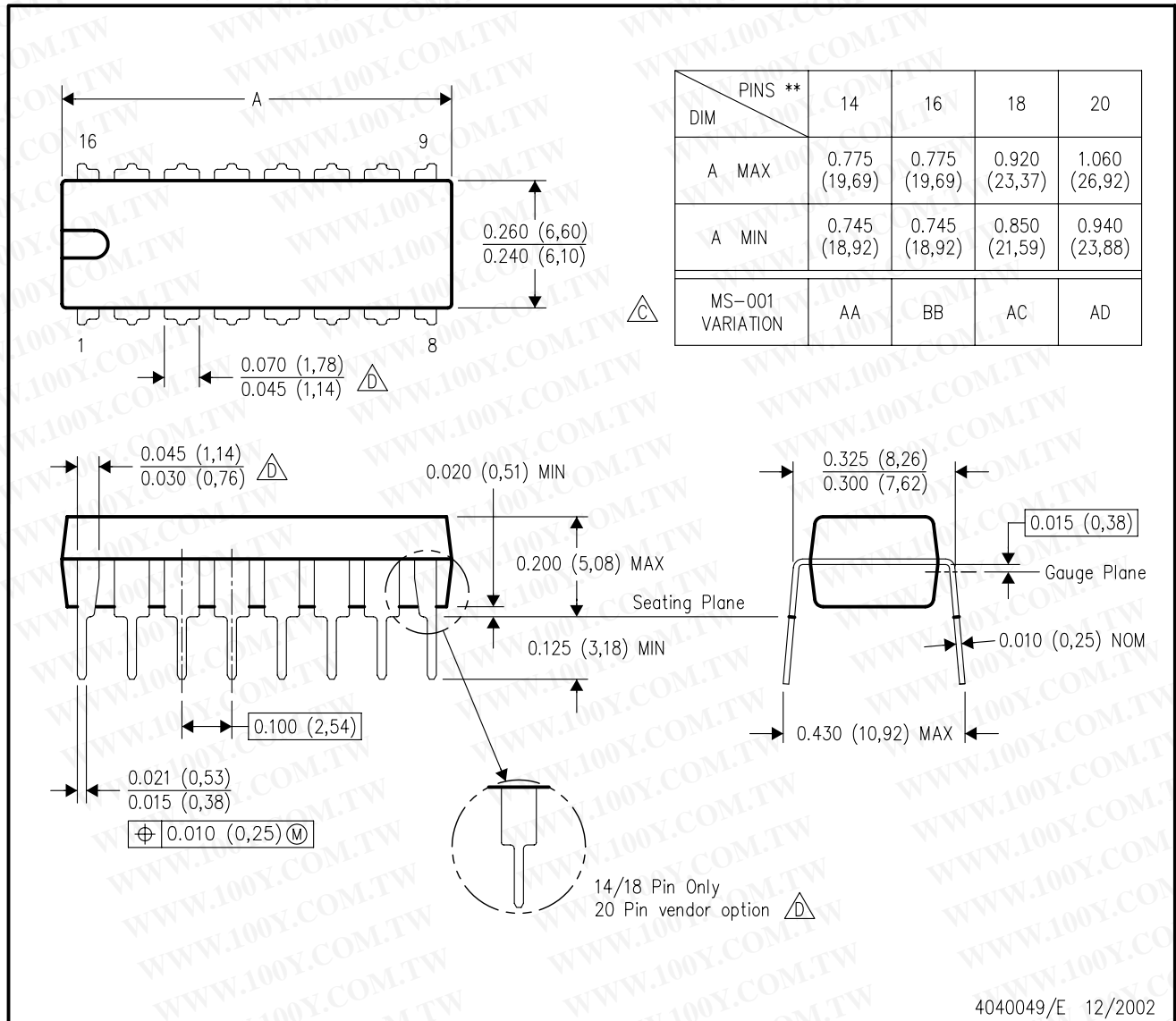

- NOTES:
- A. All linear dimensions are in inches (millimeters).
  - B. This drawing is subject to change without notice.
  - Falls within JEDEC MS-001, except 18 and 20 pin minimum body length (Dim A).
  - The 20 pin end lead shoulder width is a vendor option, either half or full width.

勝特力材料 886-3-5753170  
 勝特力电子(上海) 86-21-34970699  
 勝特力电子(深圳) 86-755-83298787  
[Http://www.100y.com.tw](http://www.100y.com.tw)

## IMPORTANT NOTICE

Texas Instruments Incorporated and its subsidiaries (TI) reserve the right to make corrections, modifications, enhancements, improvements, and other changes to its products and services at any time and to discontinue any product or service without notice. Customers should obtain the latest relevant information before placing orders and should verify that such information is current and complete. All products are sold subject to TI's terms and conditions of sale supplied at the time of order acknowledgment.

TI warrants performance of its hardware products to the specifications applicable at the time of sale in accordance with TI's standard warranty. Testing and other quality control techniques are used to the extent TI deems necessary to support this warranty. Except where mandated by government requirements, testing of all parameters of each product is not necessarily performed.

TI assumes no liability for applications assistance or customer product design. Customers are responsible for their products and applications using TI components. To minimize the risks associated with customer products and applications, customers should provide adequate design and operating safeguards.

TI does not warrant or represent that any license, either express or implied, is granted under any TI patent right, copyright, mask work right, or other TI intellectual property right relating to any combination, machine, or process in which TI products or services are used. Information published by TI regarding third-party products or services does not constitute a license from TI to use such products or services or a warranty or endorsement thereof. Use of such information may require a license from a third party under the patents or other intellectual property of the third party, or a license from TI under the patents or other intellectual property of TI.

Reproduction of TI information in TI data books or data sheets is permissible only if reproduction is without alteration and is accompanied by all associated warranties, conditions, limitations, and notices. Reproduction of this information with alteration is an unfair and deceptive business practice. TI is not responsible or liable for such altered documentation. Information of third parties may be subject to additional restrictions.

Resale of TI products or services with statements different from or beyond the parameters stated by TI for that product or service voids all express and any implied warranties for the associated TI product or service and is an unfair and deceptive business practice. TI is not responsible or liable for any such statements.

TI products are not authorized for use in safety-critical applications (such as life support) where a failure of the TI product would reasonably be expected to cause severe personal injury or death, unless officers of the parties have executed an agreement specifically governing such use. Buyers represent that they have all necessary expertise in the safety and regulatory ramifications of their applications, and acknowledge and agree that they are solely responsible for all legal, regulatory and safety-related requirements concerning their products and any use of TI products in such safety-critical applications, notwithstanding any applications-related information or support that may be provided by TI. Further, Buyers must fully indemnify TI and its representatives against any damages arising out of the use of TI products in such safety-critical applications.

TI products are neither designed nor intended for use in military/aerospace applications or environments unless the TI products are specifically designated by TI as military-grade or "enhanced plastic." Only products designated by TI as military-grade meet military specifications. Buyers acknowledge and agree that any such use of TI products which TI has not designated as military-grade is solely at the Buyer's risk, and that they are solely responsible for compliance with all legal and regulatory requirements in connection with such use.

TI products are neither designed nor intended for use in automotive applications or environments unless the specific TI products are designated by TI as compliant with ISO/TS 16949 requirements. Buyers acknowledge and agree that, if they use any non-designated products in automotive applications, TI will not be responsible for any failure to meet such requirements.

Following are URLs where you can obtain information on other Texas Instruments products and application solutions:

### Products

Amplifiers	<a href="http://www.ti.com/amplifier">amplifier.ti.com</a>
Data Converters	<a href="http://www.ti.com/dataconverter">dataconverter.ti.com</a>
DSP	<a href="http://www.ti.com/dsp">dsp.ti.com</a>
Clocks and Timers	<a href="http://www.ti.com/clocks">www.ti.com/clocks</a>
Interface	<a href="http://www.ti.com/interface">interface.ti.com</a>
Logic	<a href="http://www.ti.com/logic">logic.ti.com</a>
Power Mgmt	<a href="http://www.ti.com/power">power.ti.com</a>
Microcontrollers	<a href="http://www.ti.com/microcontroller">microcontroller.ti.com</a>
RFID	<a href="http://www.ti.com/rfid">www.ti-rfid.com</a>
RF/IF and ZigBee® Solutions	<a href="http://www.ti.com/lprf">www.ti.com/lprf</a>

### Applications

Audio	<a href="http://www.ti.com/audio">www.ti.com/audio</a>
Automotive	<a href="http://www.ti.com/automotive">www.ti.com/automotive</a>
Broadband	<a href="http://www.ti.com/broadband">www.ti.com/broadband</a>
Digital Control	<a href="http://www.ti.com/digitalcontrol">www.ti.com/digitalcontrol</a>
Medical	<a href="http://www.ti.com/medical">www.ti.com/medical</a>
Military	<a href="http://www.ti.com/military">www.ti.com/military</a>
Optical Networking	<a href="http://www.ti.com/opticalnetwork">www.ti.com/opticalnetwork</a>
Security	<a href="http://www.ti.com/security">www.ti.com/security</a>
Telephony	<a href="http://www.ti.com/telephony">www.ti.com/telephony</a>
Video & Imaging	<a href="http://www.ti.com/video">www.ti.com/video</a>
Wireless	<a href="http://www.ti.com/wireless">www.ti.com/wireless</a>

Mailing Address: Texas Instruments, Post Office Box 655303, Dallas, Texas 75265  
Copyright © 2008, Texas Instruments Incorporated

勝特力材料 886-3-5753170  
勝特力电子(上海) 86-21-34970699  
勝特力电子(深圳) 86-755-83298787  
[Http://www.100y.com.tw](http://www.100y.com.tw)