

DATA SHEET

74LVC163

Presettable synchronous 4-bit
binary counter; synchronous reset

Product specification
Supersedes data of 2003 June 02

2004 May 05

勝特力材料 886-3-5753170
勝特力电子(上海) 86-21-34970699
勝特力电子(深圳) 86-755-83298787
[Http://www.100y.com.tw](http://www.100y.com.tw)

Presettable synchronous 4-bit binary counter; synchronous reset

74LVC163

FEATURES

- Wide supply voltage range from 1.2 V to 3.6 V
- Complies with JEDEC standard JESD8-B/JESD36
- Inputs accept voltages up to 5.5 V
- CMOS low power consumption
- Direct interface with TTL levels
- Synchronous reset
- Synchronous counting and loading
- Two count enable inputs for n-bit cascading
- Positive edge-triggered clock.
- ESD protection:
 - HBM EIA/JESD22-A114-B exceeds 2000 V
 - MM EIA/JESD22-A115-A exceeds 200 V.
- Specified from $-40\text{ }^{\circ}\text{C}$ to $+85\text{ }^{\circ}\text{C}$ and $-40\text{ }^{\circ}\text{C}$ to $+125\text{ }^{\circ}\text{C}$.

DESCRIPTION

The 74LVC163 is a high-performance, low-power, low-voltage, Si-gate CMOS device and superior to most advanced CMOS compatible TTL families.

The 74LVC163 is a synchronous presettable binary counter which features an internal look-head carry and can be used for high-speed counting. Synchronous operation is provided by having all flip-flops clocked simultaneously on the positive-going edge of the clock (pin CP). The outputs (pins Q0 to Q3) of the counters may be preset to a

HIGH-level or LOW-level. A LOW-level at the parallel enable input (pin $\overline{\text{PE}}$) disables the counting action and causes the data at the data inputs (pins D0 to D3) to be loaded into the counter on the positive-going edge of the clock (provided that the set-up and hold time requirements for PE are met). Preset takes place regardless of the levels at count enable inputs (pins CEP and CET). A LOW-level at the master reset input (pin $\overline{\text{MR}}$) sets all four outputs of the flip-flops (pins Q0 to Q3) to LOW-level after the next positive-going transition on the clock input (pin CP) (provided that the set-up and hold time requirements for PE are met). This action occurs regardless of the levels at input pins $\overline{\text{PE}}$, CET and CEP. This synchronous reset feature enables the designer to modify the maximum count with only one external NAND gate.

The look-ahead carry simplifies serial cascading of the counters. Both count enable inputs (pins CEP and CET) must be HIGH to count. The CET input is fed forward to enable the terminal count output (pin TC). The TC output thus enabled will produce a HIGH output pulse of a duration approximately equal to a HIGH-level output of Q0. This pulse can be used to enable the next cascaded stage.

The maximum clock frequency for the cascaded counters is determined by t_{PHL} (propagation delay CP to TC) and t_{su} (set-up time CEP to CP) according to the

$$\text{formula: } f_{\text{max}} = \frac{1}{t_{\text{PHL}(\text{max})} + t_{\text{su}}}$$

勝特力材料 886-3-5753170
 勝特力电子(上海) 86-21-34970699
 勝特力电子(深圳) 86-755-83298787
[Http://www.100y.com.tw](http://www.100y.com.tw)

Presettable synchronous 4-bit binary counter; synchronous reset

74LVC163

QUICK REFERENCE DATA

GND = 0 V; $T_{amb} = 25\text{ }^{\circ}\text{C}$; $t_r = t_f \leq 2.5\text{ ns}$.

SYMBOL	PARAMETER	CONDITIONS	TYPICAL	UNIT
t_{PHL}/t_{PLH}	propagation delay: CP to Qn CP to TC CET to TC	$C_L = 50\text{ pF}$; $V_{CC} = 3.3\text{ V}$	4.0 4.6 3.5	ns ns ns
$f_{clk(max)}$	maximum clock frequency		200	MHz
C_I	input capacitance		5.0	pF
C_{PD}	power dissipation capacitance per gate	notes 1 and 2	17	pF

Notes

1. C_{PD} is used to determine the dynamic power dissipation (P_D in μW).

$$P_D = C_{PD} \times V_{CC}^2 \times f_i \times N + \Sigma(C_L \times V_{CC}^2 \times f_o) \text{ where:}$$

f_i = input frequency in MHz;

f_o = output frequency in MHz;

C_L = output load capacitance in pF;

V_{CC} = supply voltage in Volts;

N = total load switching outputs;

$\Sigma(C_L \times V_{CC}^2 \times f_o)$ = sum of the outputs.

2. The condition is $V_I = \text{GND}$ to V_{CC} .

勝特力材料 886-3-5753170
 勝特力电子(上海) 86-21-34970699
 勝特力电子(深圳) 86-755-83298787
[Http://www.100y.com.tw](http://www.100y.com.tw)

ORDERING INFORMATION

TYPE NUMBER	TEMPERATURE RANGE	PINS	PACKAGE	MATERIAL	CODE
74LVC163D	-40 °C to +125 °C	16	SO16	plastic	SOT109-1
74LVC163DB	-40 °C to +125 °C	16	SSOP16	plastic	SOT338-1
74LVC163PW	-40 °C to +125 °C	16	TSSOP16	plastic	SOT403-1
74LVC163BQ	-40 °C to +125 °C	16	DHVQFN16	plastic	SOT763-1

Presettable synchronous 4-bit binary counter; synchronous reset

74LVC163

FUNCTION TABLE

See note 1.

OPERATING MODES	INPUT						OUTPUT	
	MR	CP	CEP	CET	PE	Dn	Qn	TC
Reset (clear)	l	↑	X	X	X	X	L	L
Parallel load	h	↑	X	X	l	l	L	L
	h	↑	X	X	l	h	H	*
Count	h	↑	h	h	h	X	count	*
Hold (do nothing)	h	X	l	X	h	X	q _n	*
	h	X	X	l	h	X	q _n	L

Note

1. * = the TC output is HIGH when CET is HIGH and the counter is at terminal count (HHHH).

H = HIGH voltage level.

h = HIGH voltage level one set-up time prior to the LOW-to-HIGH clock transition.

L = LOW voltage level.

l = LOW voltage level one set-up time prior to the LOW-to-HIGH clock transition.

q = lower case letters indicate the state of the referenced output one set-up time prior to the LOW-to-HIGH clock transition.

X = don't care.

↑ = LOW-to-HIGH clock transition.

PINNING

PIN	SYMBOL	DESCRIPTION
1	MR	synchronous master reset (active LOW)
2	CP	clock input (LOW-to-HIGH, edge-triggered)
3	D0	data input
4	D1	data input
5	D2	data input
6	D3	data input
7	CEP	count enable input
8	GND	ground (0 V)
9	PE	parallel enable input (active LOW)
10	CET	count enable carry input
11	Q3	flip-flop output
12	Q2	flip-flop output
13	Q1	flip-flop output
14	Q0	flip-flop output
15	TC	terminal count output
16	V _{CC}	supply voltage

Presettable synchronous 4-bit binary counter; synchronous reset

74LVC163

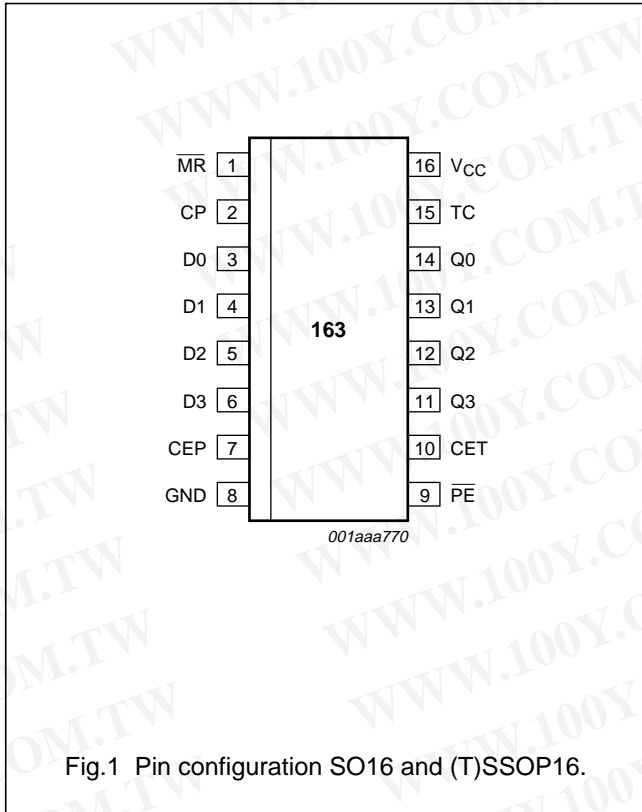

Fig.1 Pin configuration SO16 and (T)SSOP16.

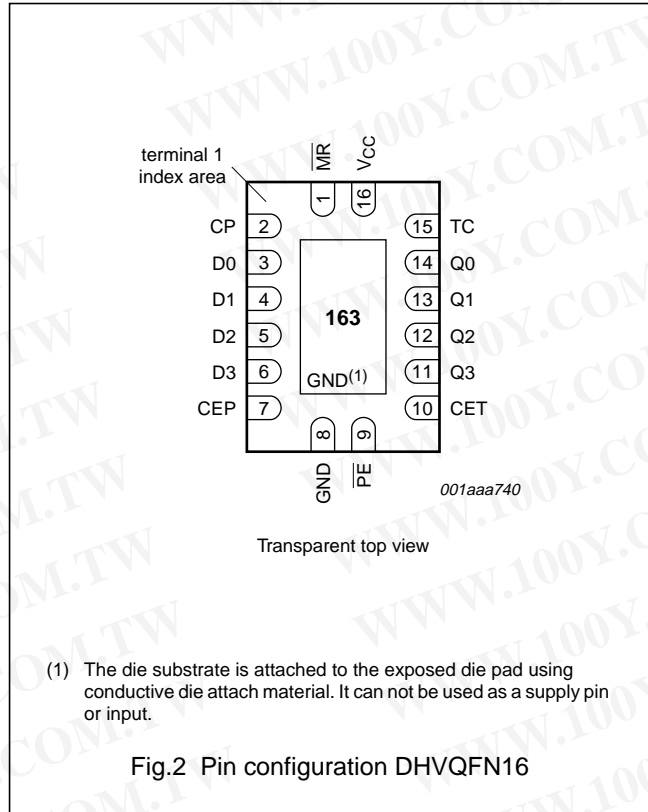

Fig.2 Pin configuration DHVQFN16

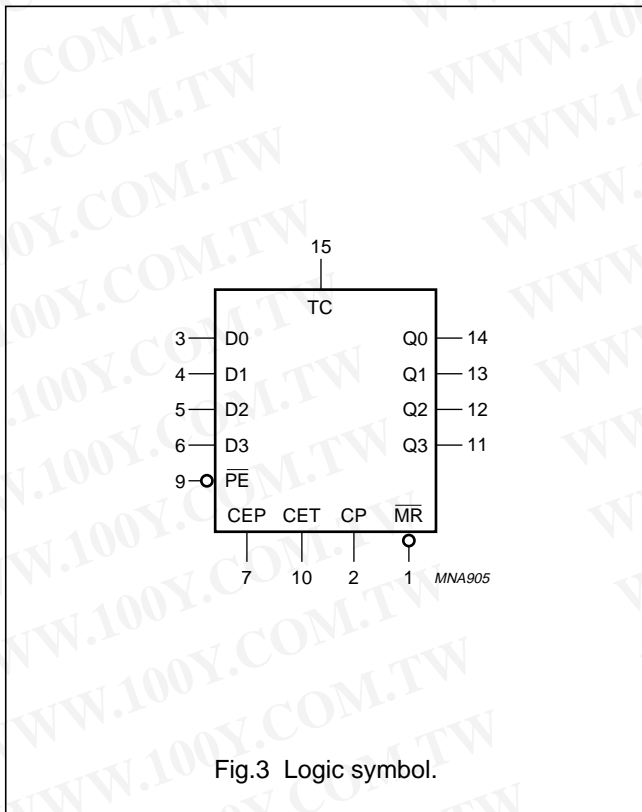

Fig.3 Logic symbol.

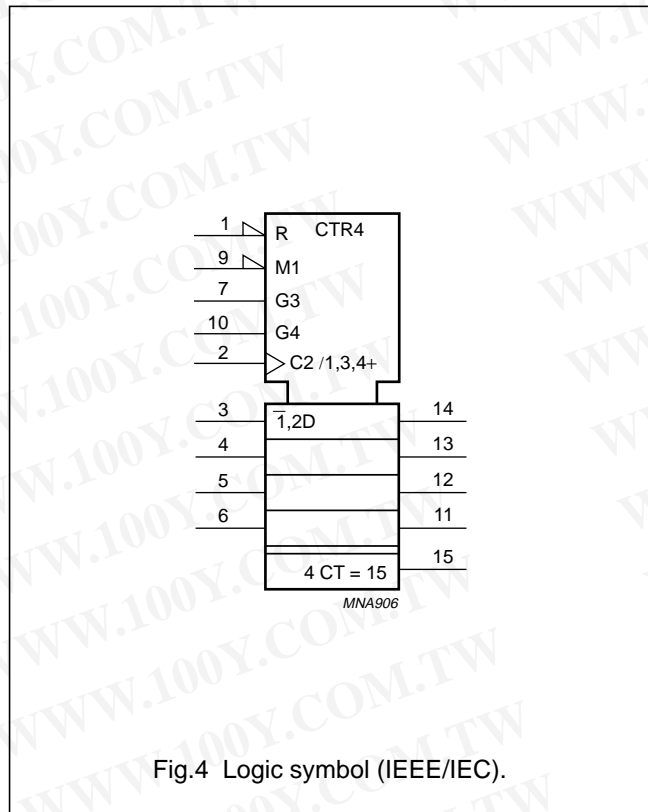

Fig.4 Logic symbol (IEEE/IEC).

Pre-settable synchronous 4-bit binary counter; synchronous reset

74LVC163

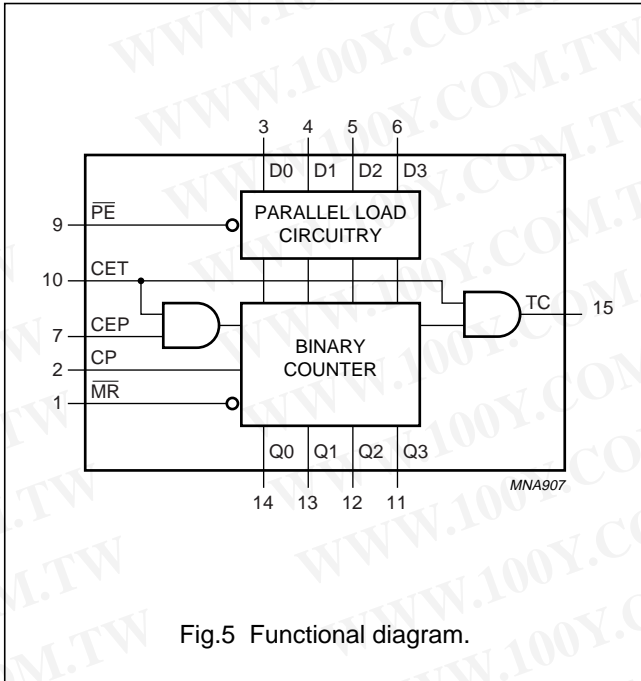

Fig.5 Functional diagram.

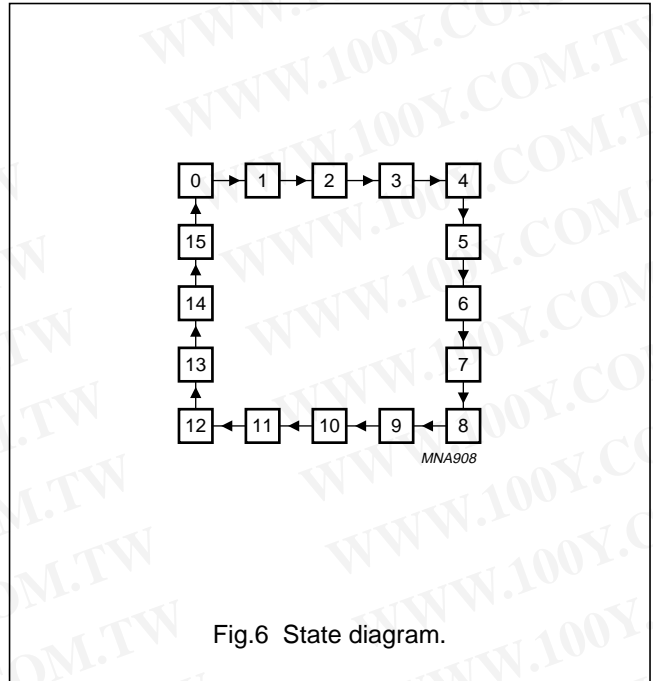

Fig.6 State diagram.

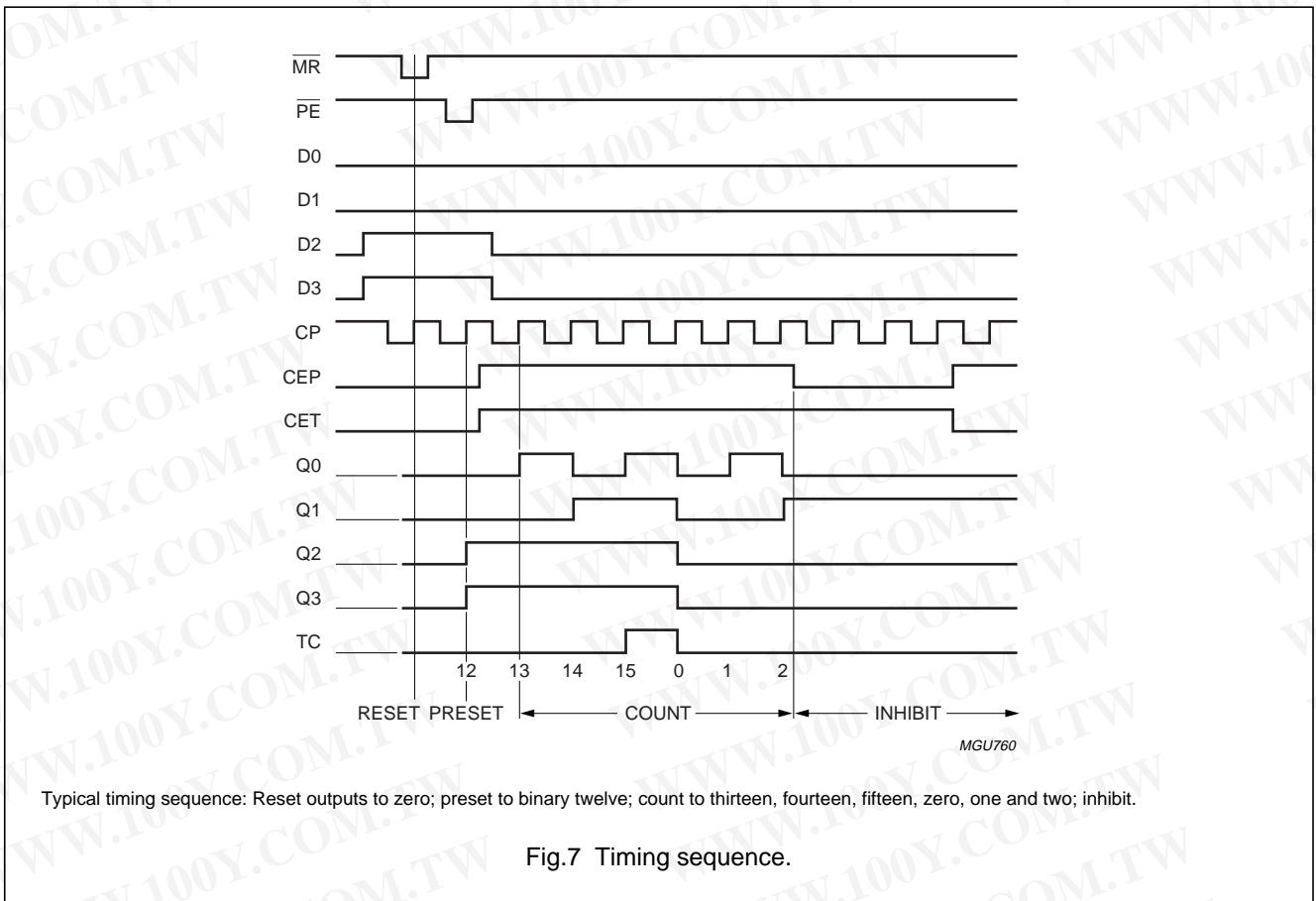

Fig.7 Timing sequence.

勝特力材料 886-3-5753170
 勝特力电子(上海) 86-21-34970699
 勝特力电子(深圳) 86-755-83298787
[Http://www.100y.com.tw](http://www.100y.com.tw)

Presetable synchronous 4-bit binary counter; synchronous reset

74LVC163

MGU761

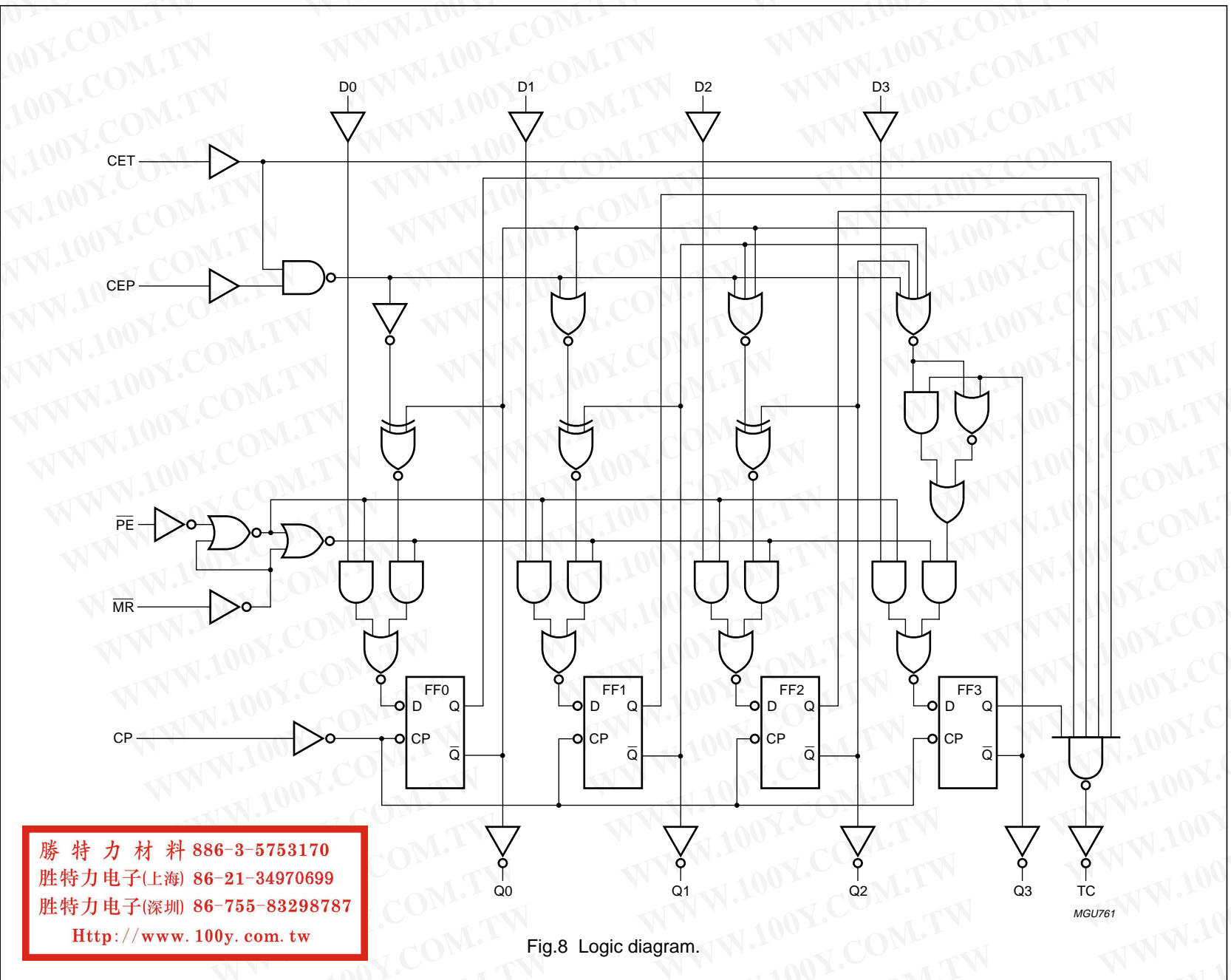

Fig.8 Logic diagram.

勝特力材料 886-3-5753170
勝特力电子(上海) 86-21-34970699
勝特力电子(深圳) 86-755-83298787
[Http://www.100y.com.tw](http://www.100y.com.tw)

Pre-settable synchronous 4-bit binary counter; synchronous reset

74LVC163

RECOMMENDED OPERATING CONDITIONS

SYMBOL	PARAMETER	CONDITIONS	MIN.	MAX.	UNIT
V _{CC}	supply voltage	for maximum speed performance	2.7	3.6	V
		for low-voltage applications	1.2	3.6	V
V _I	input voltage		0	5.5	V
V _O	output voltage		0	V _{CC}	V
T _{amb}	operating ambient temperature	in free air	-40	+125	°C
t _r , t _f	input rise and fall times	V _{CC} = 1.2 V to 2.7 V	0	20	ns/V
		V _{CC} = 2.7 V to 3.6 V	0	10	ns/V

LIMITING VALUES

In accordance with the Absolute Maximum Rating System (IEC 60134); voltages are referenced to GND (ground = 0 V).

SYMBOL	PARAMETER	CONDITIONS	MIN.	MAX.	UNIT
V _{CC}	supply voltage		-0.5	+6.5	V
I _{IK}	input diode current	V _I < 0 V	-	-50	mA
V _I	input voltage	note 1	-0.5	+6.5	V
I _{OK}	output diode current	V _O > V _{CC} or V _O < 0 V	-	±50	mA
V _O	output voltage	note 1	-0.5	V _{CC} + 0.5	V
I _O	output source or sink current	V _O = 0 V to V _{CC}	-	±50	mA
I _{CC} , I _{GND}	V _{CC} or GND current		-	±100	mA
T _{stg}	storage temperature		-65	+150	°C
P _{tot}	power dissipation	T _{amb} = -40 °C to +125 °C; note 2	-	500	mW

Notes

- The input and output voltage ratings may be exceeded if the input and output current ratings are observed.
- For SO16 packages: above 70 °C the value of P_{tot} derates linearly with 8 mW/K.
For SSOP16 and TSSOP16 packages: above 60 °C the value of P_{tot} derates linearly with 5.5 mW/K.
For DHVQFN16 packages: above 60 °C the value of P_{tot} derates linearly with 4.5 mW/K.

勝特力材料 886-3-5753170
 勝特力电子(上海) 86-21-34970699
 勝特力电子(深圳) 86-755-83298787
[Http://www.100y.com.tw](http://www.100y.com.tw)

Pre-settable synchronous 4-bit binary counter; synchronous reset

74LVC163

DC CHARACTERISTICS

At recommended operating conditions; voltages are referenced to GND (ground = 0 V).

SYMBOL	PARAMETER	TEST CONDITIONS		MIN.	TYP. ⁽¹⁾	MAX.	UNIT
		OTHER	V _{CC} (V)				
T_{amb} = -40 °C to +85 °C							
V _{IH}	HIGH-level input voltage		1.2	V _{CC}	–	–	V
			2.7 to 3.6	2.0	–	–	V
V _{IL}	LOW-level input voltage		1.2	–	–	GND	V
			2.7 to 3.6	–	–	0.8	V
V _{OH}	HIGH-level output voltage	V _I = V _{IH} or V _{IL}	2.7 to 3.6	V _{CC} – 0.2	V _{CC}	–	V
		I _O = –100 μA	2.7	V _{CC} – 0.5	–	–	V
		I _O = –12 mA	3.0	V _{CC} – 0.6	–	–	V
		I _O = –24 mA	3.0	V _{CC} – 0.8	–	–	V
V _{OL}	LOW-level output voltage	V _I = V _{IH} or V _{IL}	2.7 to 3.6	–	GND	0.2	V
		I _O = 100 μA	2.7	–	–	0.4	V
		I _O = 24 mA	3.0	–	–	0.55	V
I _{LI}	input leakage current	V _I = 5.5 V or GND	3.6	–	±0.1	±5	μA
I _{CC}	quiescent supply current	V _I = V _{CC} or GND; I _O = 0 A	3.6	–	0.1	10	μA
ΔI _{CC}	additional quiescent supply current per input pin	V _I = V _{CC} – 0.6 V; I _O = 0 A	2.7 to 3.6	–	5	500	μA

勝特力材料 886-3-5753170
 勝特力电子(上海) 86-21-34970699
 勝特力电子(深圳) 86-755-83298787
[Http://www.100y.com.tw](http://www.100y.com.tw)

Pre-settable synchronous 4-bit binary counter; synchronous reset

74LVC163

SYMBOL	PARAMETER	TEST CONDITIONS		MIN.	TYP. ⁽¹⁾	MAX.	UNIT
		OTHER	V _{CC} (V)				
T_{amb} = -40 °C to +125 °C							
V _{IH}	HIGH-level input voltage		1.2	V _{CC}	–	–	V
			2.7 to 3.6	2.0	–	–	V
V _{IL}	LOW-level input voltage		1.2	–	–	GND	V
			2.7 to 3.6	–	–	0.8	V
V _{OH}	HIGH-level output voltage	V _I = V _{IH} or V _{IL} I _O = -100 μA	2.7 to 3.6	V _{CC} - 0.3	–	–	V
		I _O = -12 mA	2.7	V _{CC} - 0.65	–	–	V
		I _O = -18 mA	3.0	V _{CC} - 0.75	–	–	V
		I _O = -24 mA	3.0	V _{CC} - 1	–	–	V
V _{OL}	LOW-level output voltage	V _I = V _{IH} or V _{IL} I _O = 100 μA	2.7 to 3.6	–	–	0.3	V
		I _O = 12 mA	2.7	–	–	0.6	V
		I _O = 24 mA	3.0	–	–	0.8	V
I _{LI}	input leakage current	V _I = 5.5 V or GND	3.6	–	–	±20	μA
I _{CC}	quiescent supply current	V _I = V _{CC} or GND; I _O = 0 A	3.6	–	–	40	μA
ΔI _{CC}	additional quiescent supply current per input pin	V _I = V _{CC} - 0.6 V; I _O = 0 A	2.7 to 3.6	–	–	5000	μA

Note

1. Typical values are measured at V_{CC} = 3.3 V and T_{amb} = 25 °C.

勝特力材料 886-3-5753170
 勝特力电子(上海) 86-21-34970699
 勝特力电子(深圳) 86-755-83298787
[Http://www.100y.com.tw](http://www.100y.com.tw)

Pre-settable synchronous 4-bit binary counter; synchronous reset

74LVC163

AC CHARACTERISTICSGND = 0 V; $t_r = t_f \leq 2.5$ ns; $C_L = 50$ pF; $R_L = 500 \Omega$.

SYMBOL	PARAMETER	CONDITIONS		MIN.	TYP.	MAX.	UNIT
		WAVEFORMS	V _{CC} (V)				
T_{amb} = -40 °C to +85 °C; note 1							
t _{PHL} /t _{PLH}	propagation delay CP to Qn	see Figs 9 and 14	1.2	–	18	–	ns
			2.7	1.5	–	7.3	ns
			3.0 to 3.6	1.5	4.0 ⁽²⁾	7.3	ns
	propagation delay CP to TC	see Figs 9 and 14	1.2	–	23	–	ns
			2.7	1.5	–	8.1	ns
			3.0 to 3.6	1.5	4.6 ⁽²⁾	7.9	ns
	propagation delay CET to TC	see Figs 10 and 14	1.2	–	16	–	ns
			2.7	1.5	–	6.9	ns
			3.0 to 3.6	1.5	3.5 ⁽²⁾	6.4	ns
t _w	clock pulse width HIGH or LOW	see Fig.9	2.7	5.0	–	–	ns
			3.0 to 3.6	4.0	1.2 ⁽²⁾	–	ns
t _{su}	set-up time D _n to CP	see Fig.12	2.7	3.0	–	–	ns
			3.0 to 3.6	2.5	1.0 ⁽²⁾	–	ns
	set-up time \overline{MR} , \overline{PE} to CP	see Fig.12	2.7	3.5	–	–	ns
			3.0 to 3.6	3.0	1.2 ⁽²⁾	–	ns
	set-up time CEP, CET to CP	see Fig.13	2.7	5.5	–	–	ns
			3.0 to 3.6	5.0	2.1 ⁽²⁾	–	ns
t _h	hold time D _n , \overline{PE} , CEP, CET to CP	see Figs 12 and 13	2.7	0.0	–	–	ns
			3.0 to 3.6	0.5	0.0 ⁽²⁾	–	ns
f _{max}	maximum clock pulse frequency	see Fig.9	2.7	150	–	–	MHz
			3.0 to 3.6	150	200 ⁽²⁾	–	MHz
t _{sk(0)}	skew	note 3	3.0 to 3.6	–	–	1.0	ns

勝特力材料 886-3-5753170
 勝特力电子(上海) 86-21-34970699
 勝特力电子(深圳) 86-755-83298787
[Http://www.100y.com.tw](http://www.100y.com.tw)

Pre-settable synchronous 4-bit binary counter; synchronous reset

74LVC163

SYMBOL	PARAMETER	CONDITIONS		MIN.	TYP.	MAX.	UNIT
		WAVEFORMS	V _{CC} (V)				
T_{amb} = -40 °C to +125 °C							
t _{PHL} /t _{PLH}	propagation delay CP to Qn	see Figs 9 and 14	1.2	-	-	-	ns
			2.7	1.5	-	9.5	ns
			3.0 to 3.6	1.5	-	9.5	ns
	propagation delay CP to TC	see Figs 9 and 14	1.2	-	-	-	ns
			2.7	1.5	-	10.5	ns
			3.0 to 3.6	1.5	-	10.0	ns
	propagation delay CET to TC	see Figs 10 and 14	1.2	-	-	-	ns
			2.7	1.5	-	9.0	ns
			3.0 to 3.6	1.5	-	8.0	ns
t _w	clock pulse width HIGH or LOW	see Fig.9	2.7	5.0	-	-	ns
			3.0 to 3.6	4.0	-	-	ns
t _{su}	set-up time Dn to CP	see Fig.12	2.7	3.0	-	-	ns
			3.0 to 3.6	2.5	-	-	ns
	set-up time MR, PE to CP	see Fig.12	2.7	3.5	-	-	ns
			3.0 to 3.6	3.0	-	-	ns
	set-up time CEP, CET to CP	see Fig.13	2.7	5.5	-	-	ns
			3.0 to 3.6	5.0	-	-	ns
t _h	hold time Dn, PE, CEP, CET to CP	see Figs 12 and 13	2.7	0.0	-	-	ns
			3.0 to 3.6	0.5	-	-	ns
f _{max}	maximum clock pulse frequency	see Fig.9	2.7	150	-	-	MHz
			3.0 to 3.6	150	-	-	MHz
t _{sk(0)}	skew	note 3	3.0 to 3.6	-	-	1.5	ns

Notes

1. All typical values are measured at T_{amb} = 25 °C.
2. Typical values are measured at V_{CC} = 3.3 V.
3. Skew between any two outputs of the same package switching in the same direction. This parameter is guaranteed by design.

勝特力材料 886-3-5753170
 勝特力电子(上海) 86-21-34970699
 勝特力电子(深圳) 86-755-83298787
[Http://www.100y.com.tw](http://www.100y.com.tw)

Presettable synchronous 4-bit binary counter; synchronous reset

74LVC163

AC WAVEFORMS

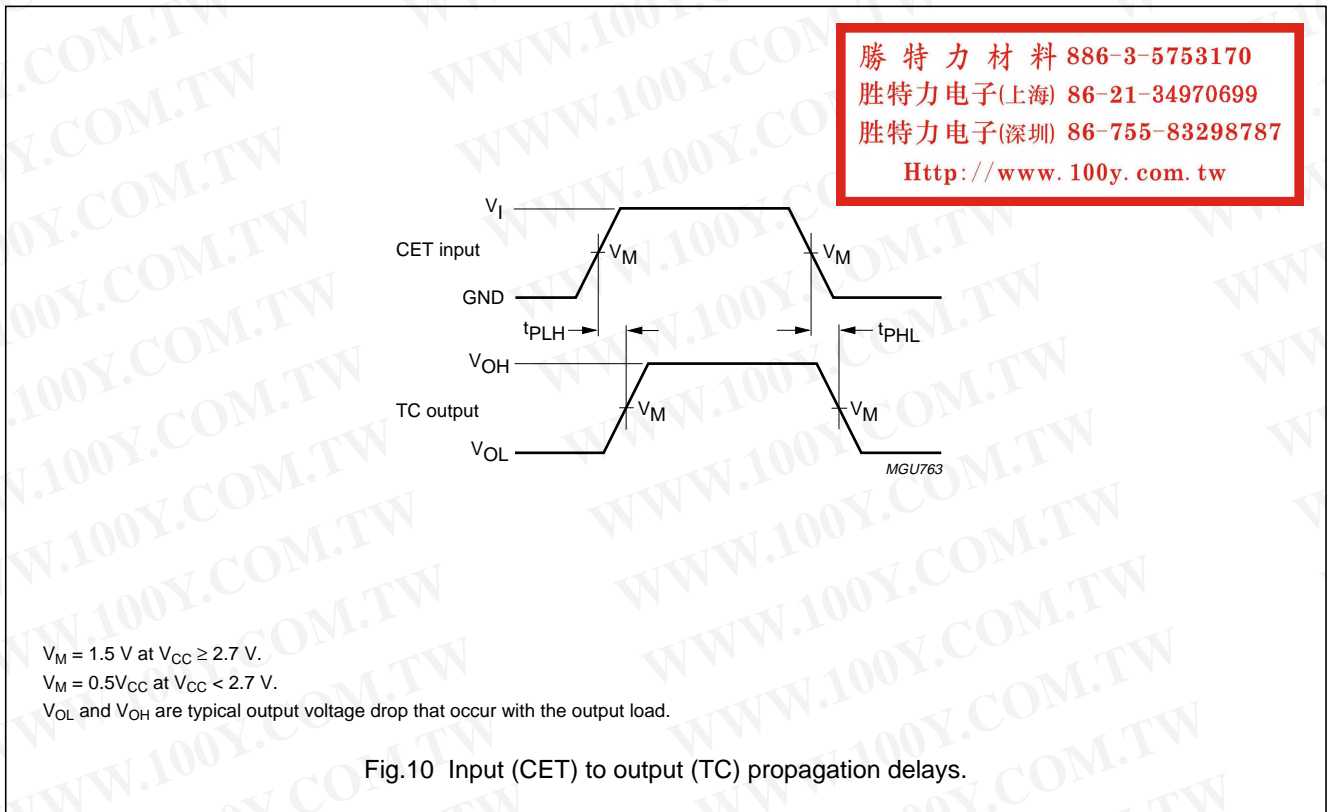
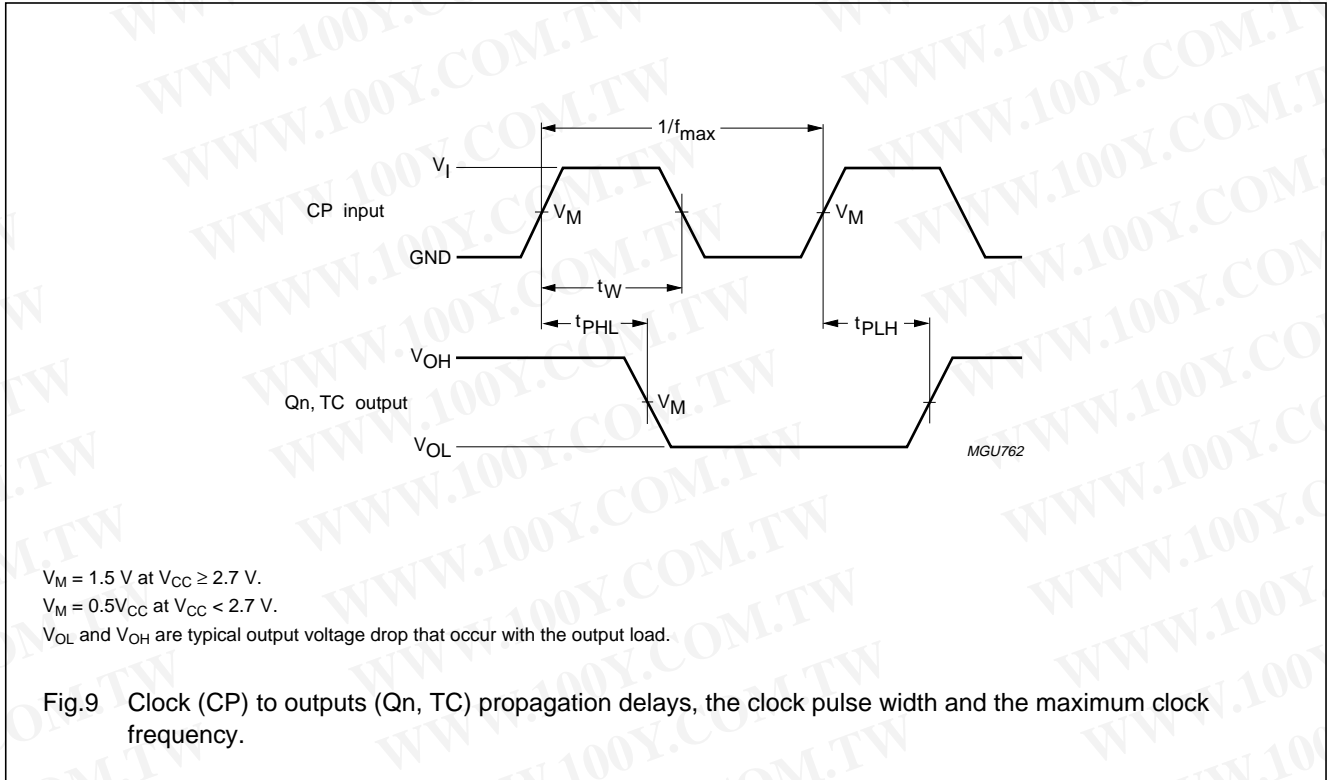

Pre-settable synchronous 4-bit binary counter; synchronous reset

74LVC163

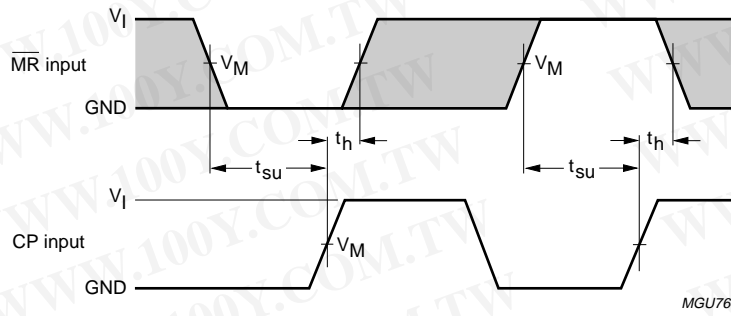

MGU764

The shaded areas indicate when the input is permitted to change for predictable output performance.

Fig.11 Master reset (\overline{MR}) pulse width, the master reset to output (Q_n , TC) propagation delays and the master reset to clock (CP) removal times.

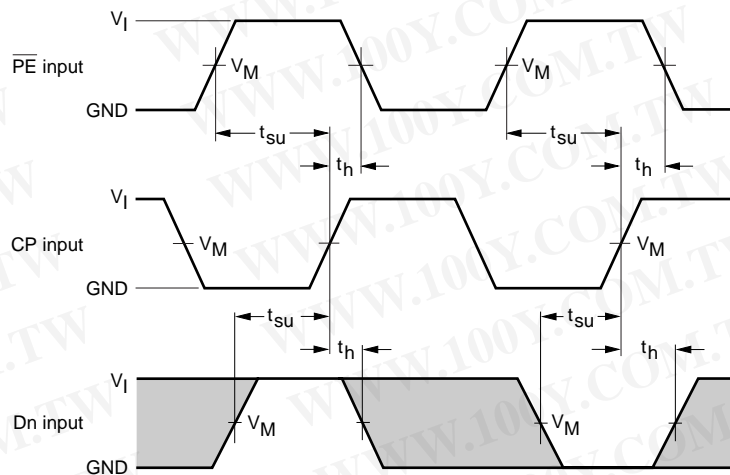

MGU765

The shaded areas indicate when the input is permitted to change for predictable output performance.

Fig.12 Set-up and hold times for the input (D_n) and parallel enable input (\overline{PE}).

Presettable synchronous 4-bit binary counter; synchronous reset

74LVC163

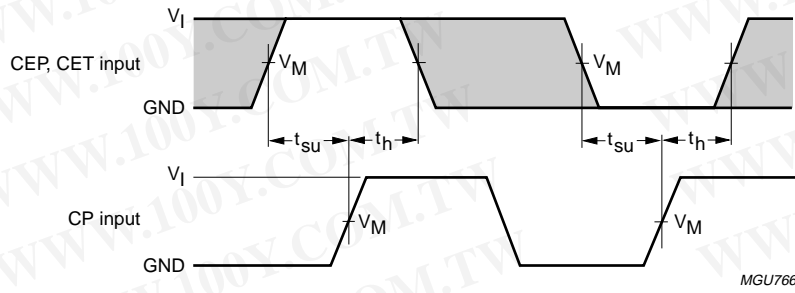

The shaded areas indicate when the input is permitted to change for predictable output performance.

Fig.13 CEP and CET set-up and hold times.

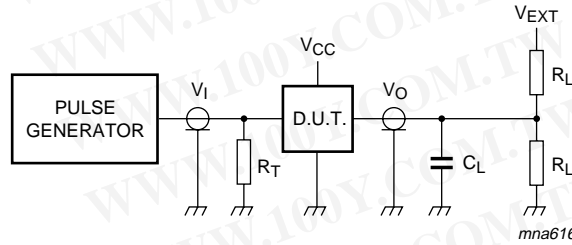

V _{CC}	V _I	C _L	R _L	V _{EXT}		
				t _{PLH} /t _{PHL}	t _{PZH} /t _{PHZ}	t _{PZL} /t _{PLZ}
1.2 V	V _{CC}	50 pF	500 Ω ⁽¹⁾	open	GND	2 × V _{CC}
2.7 V	2.7 V	50 pF	500 Ω	open	GND	2 × V _{CC}
3.0 V to 3.6 V	2.7 V	50 pF	500 Ω	open	GND	2 × V _{CC}

Note

- The circuit performs better when R_L = 1000 Ω.

Definitions for test circuits:

R_L = Load resistor.

C_L = Load capacitance including jig and probe capacitance.

R_T = Termination resistance should be equal to the output impedance Z_o of the pulse generator.

Fig.14 Load circuitry for switching times.

Pre-settable synchronous 4-bit binary counter; synchronous reset

74LVC163

PACKAGE OUTLINES

SO16: plastic small outline package; 16 leads; body width 3.9 mm

SOT109-1

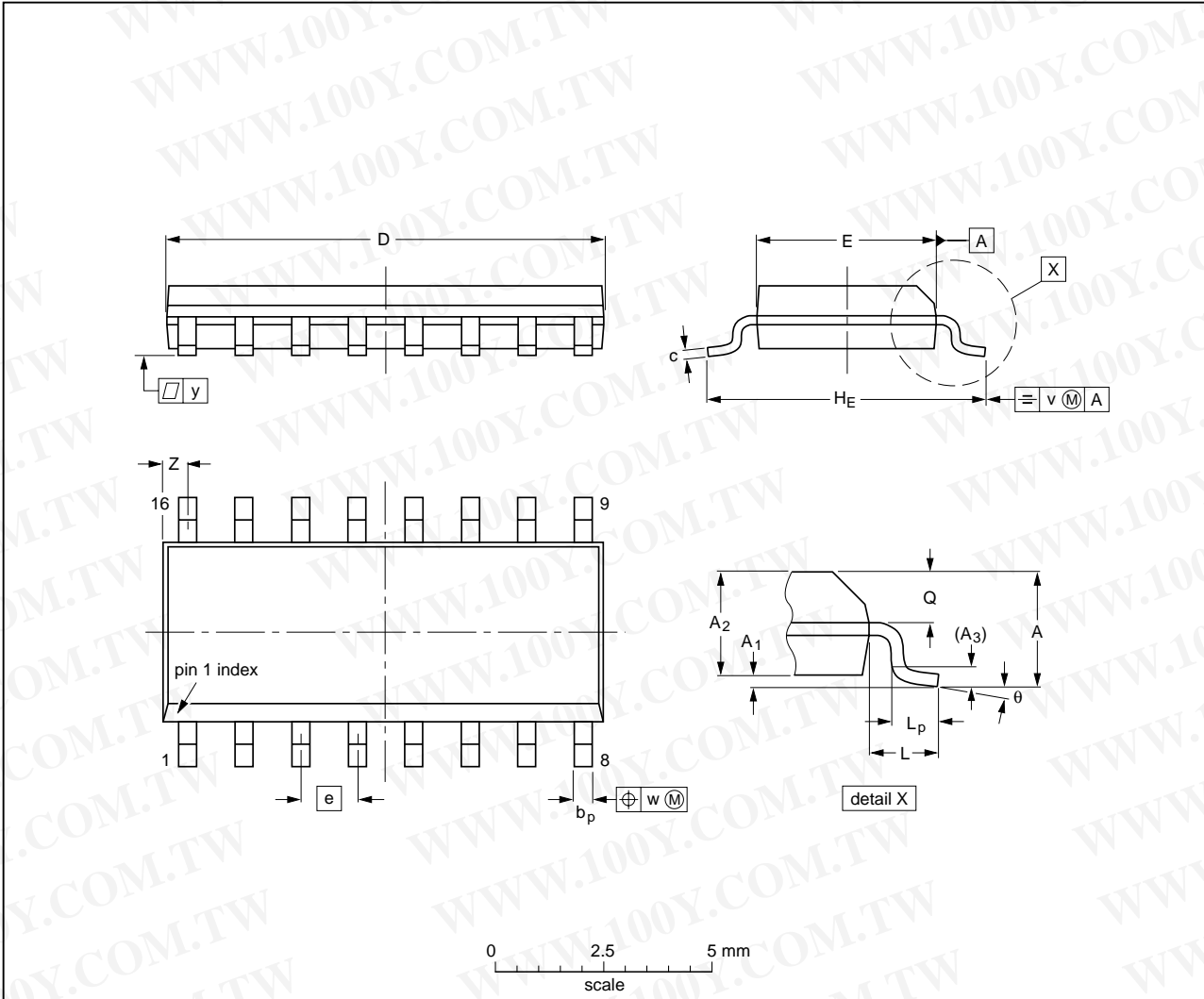

DIMENSIONS (inch dimensions are derived from the original mm dimensions)

UNIT	A max.	A ₁	A ₂	A ₃	b _p	c	D ⁽¹⁾	E ⁽¹⁾	e	H _E	L	L _p	Q	v	w	y	Z ⁽¹⁾	θ
mm	1.75	0.25 0.10	1.45 1.25	0.25	0.49 0.36	0.25 0.19	10.0 9.8	4.0 3.8	1.27	6.2 5.8	1.05	1.0 0.4	0.7 0.6	0.25	0.25	0.1	0.7 0.3	8° 0°
inches	0.069	0.010 0.004	0.057 0.049	0.01	0.019 0.014	0.0100 0.0075	0.39 0.38	0.16 0.15	0.05	0.244 0.228	0.041	0.039 0.016	0.028 0.020	0.01	0.01	0.004	0.028 0.012	

Note

1. Plastic or metal protrusions of 0.15 mm (0.006 inch) maximum per side are not included.

OUTLINE VERSION	REFERENCES			EUROPEAN PROJECTION	ISSUE DATE
	IEC	JEDEC	JEITA		
SOT109-1	076E07	MS-012			99-12-27 03-02-19

勝特力材料 886-3-5753170
 勝特力电子(上海) 86-21-34970699
 勝特力电子(深圳) 86-755-83298787
[Http://www.100y.com.tw](http://www.100y.com.tw)

Pre-settable synchronous 4-bit binary counter; synchronous reset

74LVC163

SSOP16: plastic shrink small outline package; 16 leads; body width 5.3 mm

SOT338-1

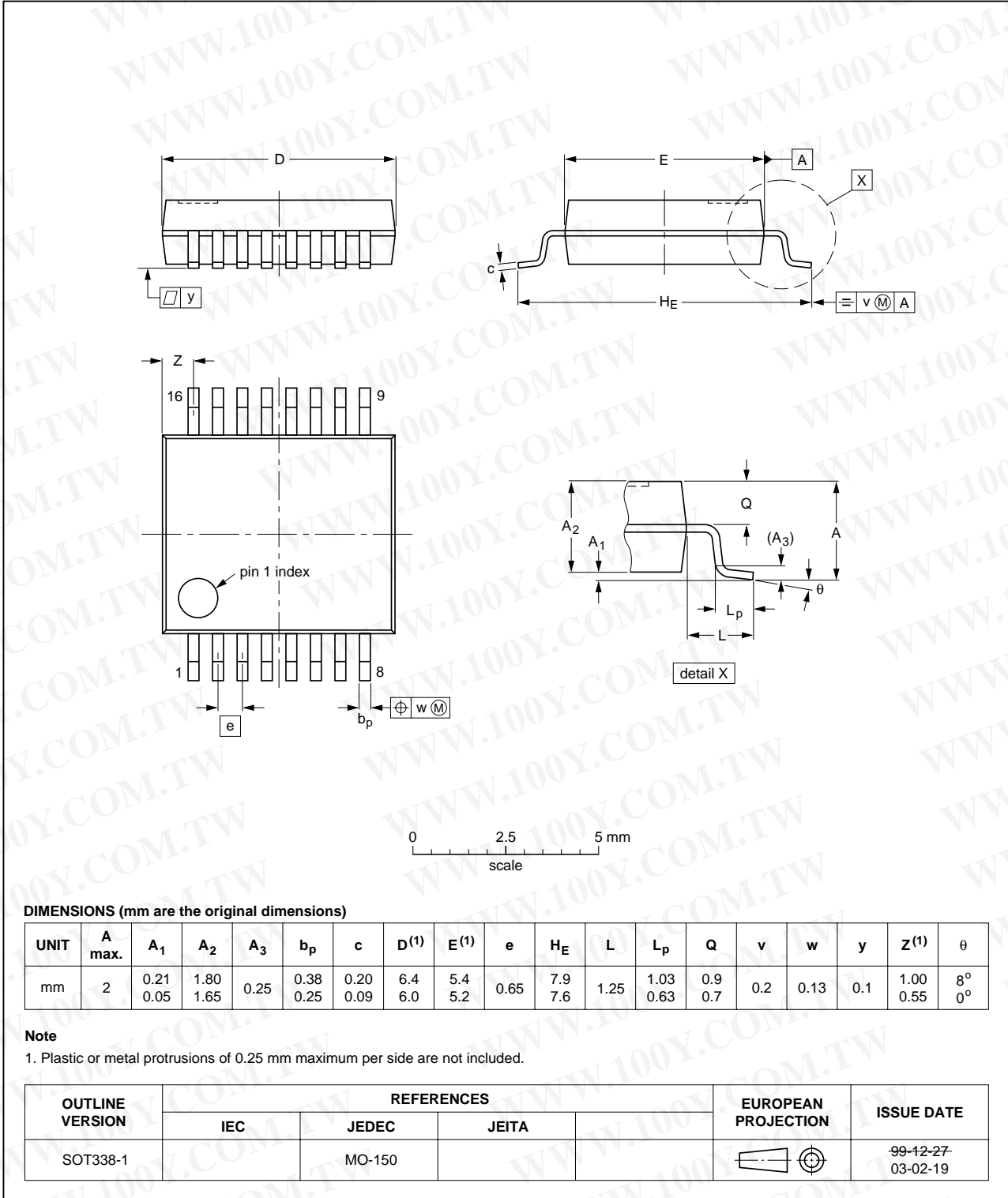

勝特力材料 886-3-5753170
 勝特力电子(上海) 86-21-34970699
 勝特力电子(深圳) 86-755-83298787
[Http://www.100y.com.tw](http://www.100y.com.tw)

Presettable synchronous 4-bit binary counter; synchronous reset

74LVC163

TSSOP16: plastic thin shrink small outline package; 16 leads; body width 4.4 mm

SOT403-1

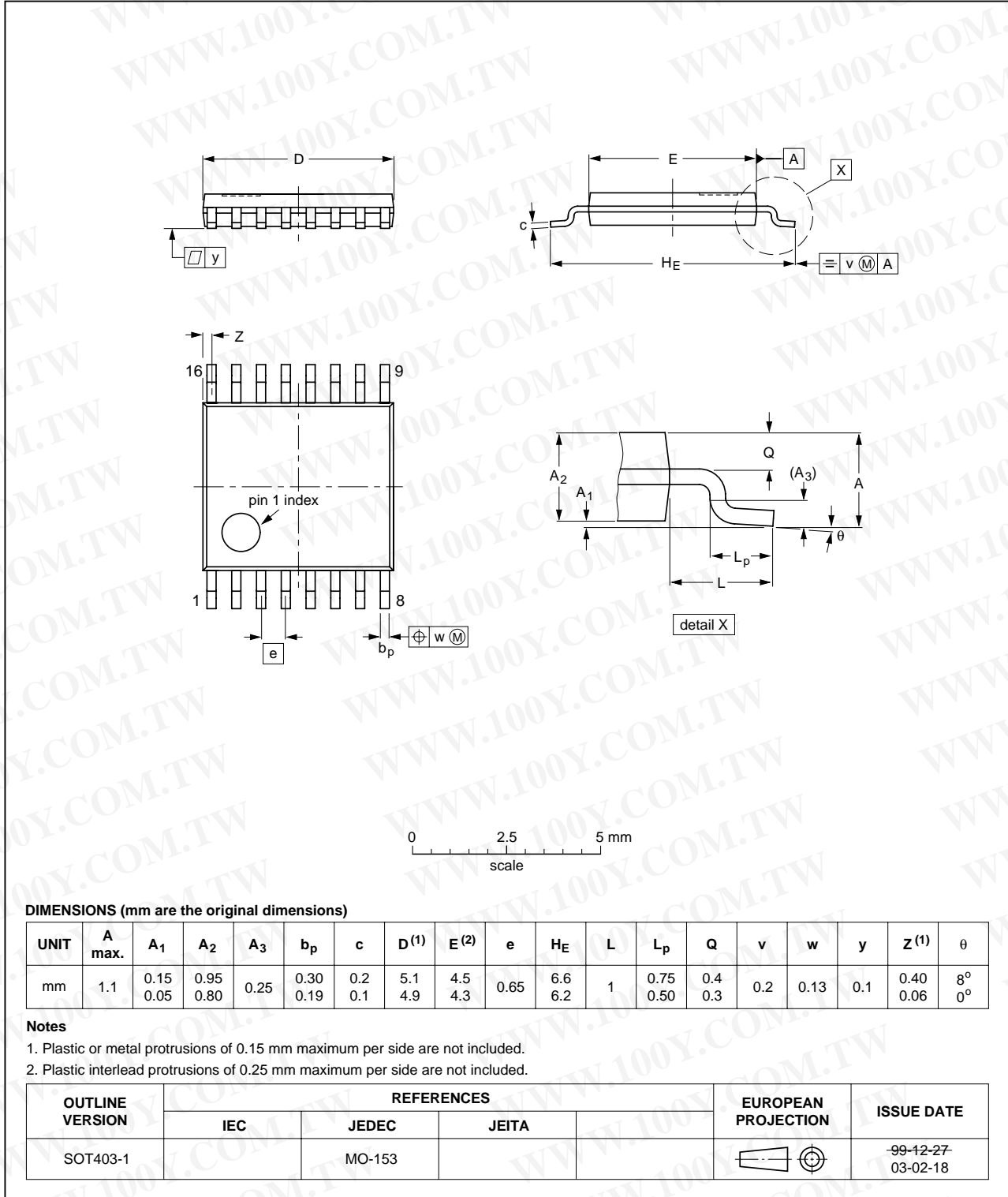

Pre-settable synchronous 4-bit binary counter; synchronous reset

74LVC163

DHVQFN16: plastic dual in-line compatible thermal enhanced very thin quad flat package; no leads; 16 terminals; body 2.5 x 3.5 x 0.85 mm

SOT763-1

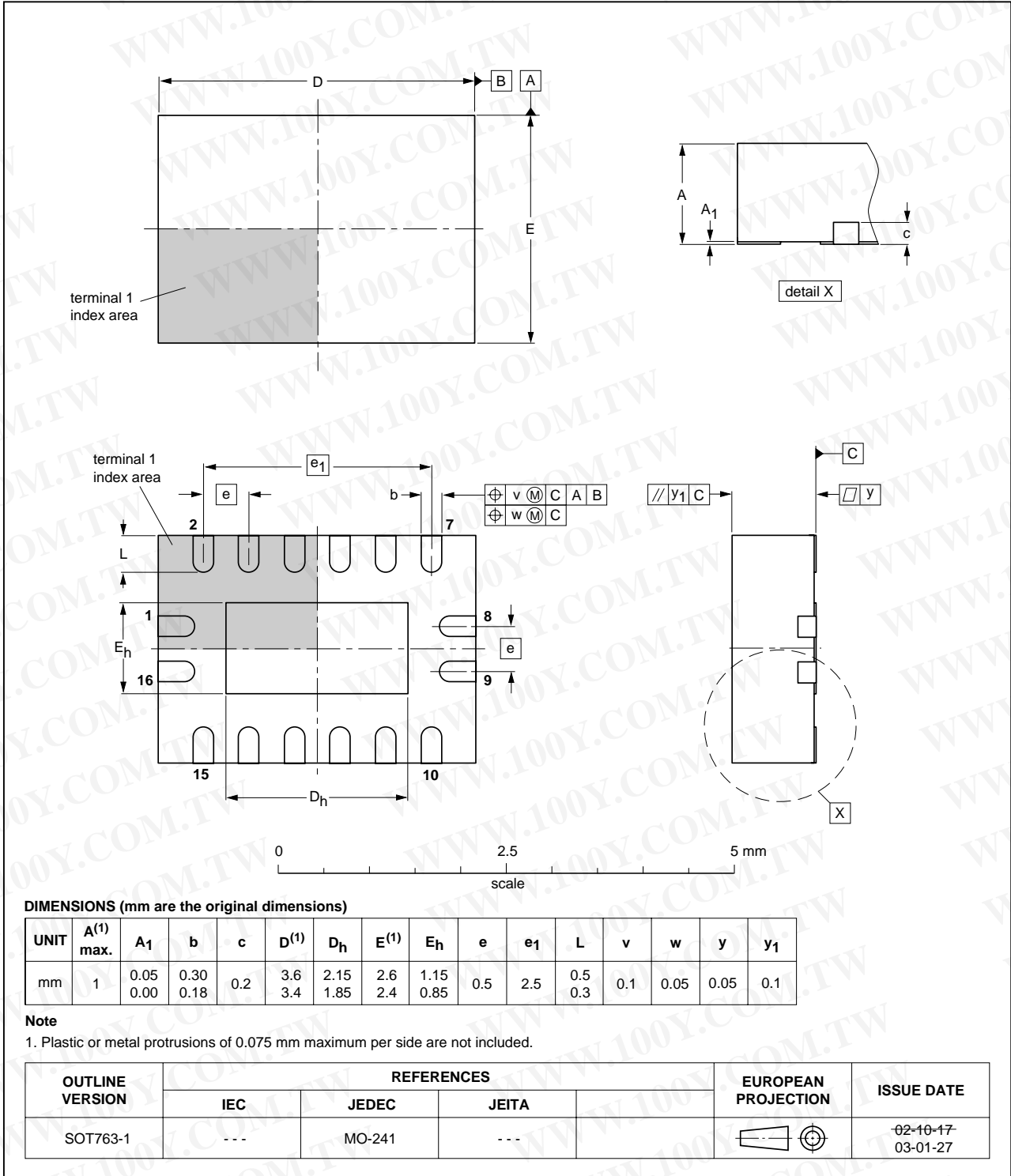

勝特力材料 886-3-5753170
 勝特力电子(上海) 86-21-34970699
 勝特力电子(深圳) 86-755-83298787
[Http://www.100y.com.tw](http://www.100y.com.tw)

Presettable synchronous 4-bit binary counter; synchronous reset

74LVC163

DATA SHEET STATUS

LEVEL	DATA SHEET STATUS ⁽¹⁾	PRODUCT STATUS ⁽²⁾⁽³⁾	DEFINITION
I	Objective data	Development	This data sheet contains data from the objective specification for product development. Philips Semiconductors reserves the right to change the specification in any manner without notice.
II	Preliminary data	Qualification	This data sheet contains data from the preliminary specification. Supplementary data will be published at a later date. Philips Semiconductors reserves the right to change the specification without notice, in order to improve the design and supply the best possible product.
III	Product data	Production	This data sheet contains data from the product specification. Philips Semiconductors reserves the right to make changes at any time in order to improve the design, manufacturing and supply. Relevant changes will be communicated via a Customer Product/Process Change Notification (CPCN).

Notes

1. Please consult the most recently issued data sheet before initiating or completing a design.
2. The product status of the device(s) described in this data sheet may have changed since this data sheet was published. The latest information is available on the Internet at URL <http://www.semiconductors.philips.com>.
3. For data sheets describing multiple type numbers, the highest-level product status determines the data sheet status.

DEFINITIONS

Short-form specification — The data in a short-form specification is extracted from a full data sheet with the same type number and title. For detailed information see the relevant data sheet or data handbook.

Limiting values definition — Limiting values given are in accordance with the Absolute Maximum Rating System (IEC 60134). Stress above one or more of the limiting values may cause permanent damage to the device. These are stress ratings only and operation of the device at these or at any other conditions above those given in the Characteristics sections of the specification is not implied. Exposure to limiting values for extended periods may affect device reliability.

Application information — Applications that are described herein for any of these products are for illustrative purposes only. Philips Semiconductors make no representation or warranty that such applications will be suitable for the specified use without further testing or modification.

DISCLAIMERS

Life support applications — These products are not designed for use in life support appliances, devices, or systems where malfunction of these products can reasonably be expected to result in personal injury. Philips Semiconductors customers using or selling these products for use in such applications do so at their own risk and agree to fully indemnify Philips Semiconductors for any damages resulting from such application.

Right to make changes — Philips Semiconductors reserves the right to make changes in the products - including circuits, standard cells, and/or software - described or contained herein in order to improve design and/or performance. When the product is in full production (status 'Production'), relevant changes will be communicated via a Customer Product/Process Change Notification (CPCN). Philips Semiconductors assumes no responsibility or liability for the use of any of these products, conveys no licence or title under any patent, copyright, or mask work right to these products, and makes no representations or warranties that these products are free from patent, copyright, or mask work right infringement, unless otherwise specified.

Philips Semiconductors – a worldwide company

Contact information

For additional information please visit <http://www.semiconductors.philips.com>. Fax: +31 40 27 24825

For sales offices addresses send e-mail to: sales.addresses@www.semiconductors.philips.com.

勝特力材料 886-3-5753170
勝特力电子(上海) 86-21-34970699
勝特力电子(深圳) 86-755-83298787
[Http://www.100y.com.tw](http://www.100y.com.tw)

© Koninklijke Philips Electronics N.V. 2004

SCA76

All rights are reserved. Reproduction in whole or in part is prohibited without the prior written consent of the copyright owner.

The information presented in this document does not form part of any quotation or contract, is believed to be accurate and reliable and may be changed without notice. No liability will be accepted by the publisher for any consequence of its use. Publication thereof does not convey nor imply any license under patent- or other industrial or intellectual property rights.

Printed in The Netherlands

R20/05/pp21

Date of release: 2004 May 05

Document order number: 9397 750 13116

Let's make things better.

Philips
Semiconductors



PHILIPS